

 **REMOTE START**

PUSH BUTTON
ELECTRIC START

ENGINE
START
STOP



iGen4500
Digital Inverter Generator
3700 Running Watts | 4500 Peak Watts



⚠ WARNING

Operating, servicing and maintaining this equipment can expose you to chemicals including engine exhaust, carbon monoxide, phthalates, and lead, which are known to the State of California to cause cancer and birth defects or other reproductive harm. To minimize exposure, avoid breathing exhaust, do not idle the engine except as necessary, service your equipment in a well-ventilated area and wear gloves or wash your hands frequently when servicing your equipment. For more information go to www.P65Warnings.ca.gov.

DISCLAIMERS:

All information, illustrations and specifications in this manual are based on the latest information available at the time of publishing. The illustrations used in this manual are intended as representative reference views only. Moreover, because of our continuous product improvement policy, we may modify information, illustrations and/or specifications to explain and/or exemplify a product, service or maintenance improvement. We reserve the right to make any change at any time without notice. Some images may vary depending upon which model is shown.

ALL RIGHTS RESERVED:

No part of this publication may be reproduced or used in any form by any means – graphic, electronic or mechanical, including photocopying, recording, taping or information storage and retrieval systems – without the written permission of MWE Investments LLC.

⚠ DANGER



This manual contains important instructions for operating this generator. For your safety and the safety of others, be sure to read this manual thoroughly before operating the generator. Failure to properly follow all instructions and precautions can cause you and others to be seriously hurt or killed.

TABLE OF CONTENTS

TECHNICAL SPECIFICATIONS3

PRODUCT REGISTRATION3

 For Your Records:3

 Product Registration3

 Product Registration Form3

SAFETY4

 Safety Definitions4

 Safety Symbol Definitions4

 General Safety Rules5

ASSEMBLY6

 Hooking Up the Battery6

FEATURES7

 Basic Inverter Features7

 Control Panel Features8

OPERATION9

 Before Starting the Inverter9

 Location Selection9

 Weather9

 Grounding the Inverter9

 High Altitude Operation9

 Power Cord10

 Inverter Paralleling Operation10

 Initial Oil Fill11

 Adding/Checking Engine Fluids and Fuel11

 Checking and/or Adding Engine Oil11

 Adding Gasoline to the Fuel Tank12

 Starting the Inverter13

 Electric Start13

 Manual Start13

 Wireless Remote Start13

 Stopping the Inverter14

 Using Efficiency Mode14

 Resetting the Reset Breaker14

 Programming Remote Start Fob14

MAINTENANCE15

 Maintenance Schedule15

 Engine Oil Maintenance16

 Checking Engine Oil16

 Adding Engine Oil16

 Changing Engine Oil17

 Air Filter Maintenance17

 Cleaning the Air Filter17

 Draining the Float Bowl18

 Spark Plug Maintenance18

 Cleaning the Spark Arrestor19

 Checking and Adjusting Valve Lash19

 Cleaning the Inverter20

 Battery Service20

 Storage21

TROUBLESHOOTING22

EXPLODED AND ENGINE VIEWS23

 iGen4500 Schematic23

 iGen4500 Exploded View24

 iGen4500 Engine View26

NOTICE

Even with a carburetor modification, engine horsepower will decrease about 3.5% for each 300 meter (1,000 foot) increase in altitude. The effect of altitude on horsepower will be greater if no carburetor modification is made. A decrease in engine horsepower will decrease the power output of the generator. Contact our service team to order altitude kits. See page 9 for altitude kit numbers.

iGen4500 TECHNICAL SPECIFICATIONS

Model	Running Watts	Peak Watts	Fuel Tank Size (G/L)	Rated Speed (RPM)	Ignition Type	Spark plug	Engine Disp (cc)	Stroke X Bore	Oil Cap. (L)	Oil Type	THD	Mobile App Ready
iGen4500	3700	4500	3.4/13	3600	TCI	F7RTC	224	70X58	0.60	10W30	<3%	No

FOR YOUR RECORDS:

Date of Purchase:	
Inverter Model Number:	
Purchased from Store/Dealer:	
Inverter Serial Number:	

IMPORTANT: KEEP YOUR PURCHASE RECEIPT TO ENSURE TROUBLE-FREE WARRANTY COVERAGE.

PRODUCT REGISTRATION

To ensure trouble-free warranty coverage, it is important you register your Westinghouse inverter. You can register your generator by either:

1. Filling in the product registration form below and mailing to:

Product Registration

MWE Investments LLC
 777 Manor Park Drive
 Columbus, Ohio 43228

2. Registering your product Online at www.westinghouseportablepower.com/register-your-product/

To register your generator you will need to locate the following information:

- Model Info Decal located on side panel.
- Serial Number.

WESTINGHOUSE PRODUCT REGISTRATION FORM

PERSONAL INFORMATION

INVERTER INFORMATION

First Name: _____ Model Number: _____

Last Name: _____ Serial Number: _____

Street Address: _____ Date Purchased: _____

Street Address: _____ Purchased From: _____

City, State, ZIP: _____

Country: _____

Phone Number: _____

E-Mail: _____



SAFETY

SAFETY DEFINITIONS

The words DANGER, WARNING, CAUTION and NOTICE are used throughout this manual to highlight important information. Be certain that the meanings of these alerts are known to all who work on or near the equipment.



This safety alert symbol appears with most safety statements. It means attention, become alert, your safety is involved! Please read and abide by the message that follows the safety alerts symbol.

DANGER

Indicates a hazardous situation which, if not avoided, *will* result in death or serious injury.

WARNING

Indicates a hazardous situation which, if not avoided, *could* result in death or serious injury.

CAUTION

Indicates a hazardous situation which, if not avoided, *could* result in minor or moderate injury.

NOTICE

Indicates a situation which can cause damage to the generator, personal property and/or the environment, or cause the equipment to operate improperly.

NOTE: Indicates a procedure, practice or condition that should be followed in order for the generator to function in the manner intended.

SAFETY SYMBOL DEFINITIONS

Symbol	Description
	Safety Alert Symbol
	Asphyxiation Hazard
	Burn Hazard
	Burst/Pressure Hazard
	Don't leave tools in the area
	Electrical Shock Hazard
	Explosion Hazard
	Fire Hazard
	Lifting Hazard
	Pinch-Point Hazard
	Read Manufacturer's Instructions
	Read Safety Messages Before Proceeding
	Wear Personal Protective Equipment (PPE)

SAFETY

GENERAL SAFETY RULES

DANGER



Never use the inverter in a location that is wet or damp. Never expose the inverter to rain, snow, water spray or standing water while in use. Protect the inverter from all hazardous weather conditions. Moisture or ice can cause a short circuit or other malfunction in the electrical circuit.



Never operate the inverter in an enclosed area. Engine exhaust contains carbon monoxide. Only operate the inverter outside and away from windows, doors and vents.

WARNING



Voltage produced by the inverter could result in death or serious injury.

- Never operate the inverter in rain or a flood plain unless proper precautions are taken to avoid being subject to rain or a flood.
- Never use worn or damaged extension cords.
- Always have a licensed electrician connect the inverter to the utility circuit.
- Never touch an operating inverter if the inverter is wet or if you have wet hands.
- Never operate the inverter in highly conductive areas such as around metal decking or steel works.
- Always use grounded extension cords. Always use three-wire or double-insulated power tools.
- Never touch live terminals or bare wires while the inverter is operating.
- Be sure the inverter is properly grounded before operating.

WARNING



Gasoline and gasoline vapors are extremely flammable and explosive under certain conditions.

- Always refuel the generator outdoors, in a well-ventilated area.
- Never remove the fuel cap with the engine running.
- Never refuel the inverter while the engine is running. Always turn engine off and allow the generator to cool before refueling.
- Only fill fuel tank with gasoline.
- Keep sparks, open flames or other form of ignition (such as match, cigarette, static electric source) away when refueling.
- Never overfill the fuel tank. Leave room for fuel to expand. Overfilling the fuel tank can result in a sudden overflow of gasoline and result in spilled gasoline coming in contact with HOT surfaces. Spilled fuel can ignite. If fuel is spilled on the inverter, wipe up any spills immediately. Dispose of rag properly. Allow area of spilled fuel to dry before operating the inverter.
- Wear eye protection while refueling.
- Never use gasoline as a cleaning agent.
- Store any containers containing gasoline in a well-ventilated area, away from any combustibles or source of ignition.
- Check for fuel leaks after refueling. Never operate the engine if a fuel leak is discovered.

WARNING



Never operate the inverter if powered items overheat, electrical output drops, there is sparking, flames or smoke coming from the inverter, or if the receptacles are damaged.



Never use the inverter to power medical support equipment.



Always remove any tools or other service equipment used during maintenance from the inverter before operating.

NOTICE

Never modify the inverter.

Never operate the inverter if it vibrates at high levels, if engine speed changes greatly or if the engine misfires often.

Always disconnect tools or appliances from the inverter before starting.

ASSEMBLY

HOOKING UP THE BATTERY

⚠ WARNING



To avoid electric shock:

- ALWAYS connect the positive (+) battery cable (red boot) first when connecting battery cables.
- ALWAYS disconnect the negative (-) battery cable (black boot) first when disconnecting battery cables.
- NEVER connect the negative (-) battery cable (black boot) to the positive (+) post on the battery.
- NEVER connect the positive (+) battery cable (red boot) to the negative (-) post on the battery.
- NEVER touch both battery posts simultaneously.
- NEVER place a metal tool across both battery posts.
- ALWAYS use insulated or nonconducting tools when installing the battery.

NOTE: THE INVERTER COMES EQUIPPED WITH THE POSITIVE BATTERY CABLE (RED BOOT) ALREADY ATTACHED.

1. Unclip the battery access panel on the back of the unit next to the muffler (see Figure 1).

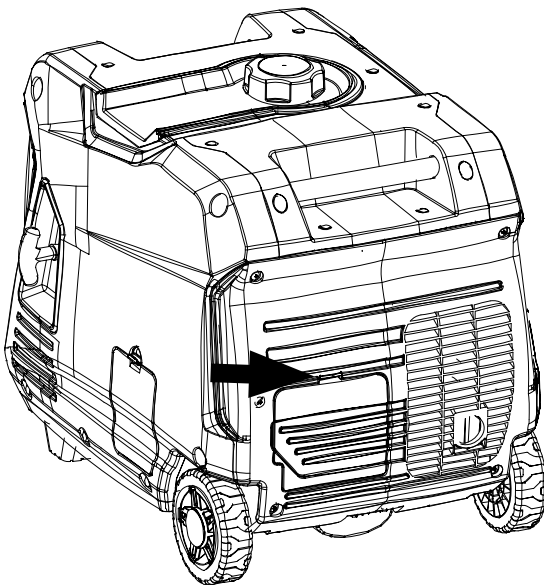

Figure 1: Battery Service Panel

2. Verify the positive (+) battery cable (red boot) is securely tightened to the positive (+) battery post. Make sure boot is over battery post.
3. Carefully remove the protective wrapping around the lug of the negative (-) battery cable (black boot).
4. Locate negative (-) cable attached to alternator cable, remove tie and route to the negative (-) battery post.
5. Pull back the black boot and securely attach the negative (-) battery cable (black boot) to the negative (-) battery post as shown in Figure 2. Replace the black boot so it protects the cable lug and battery post.

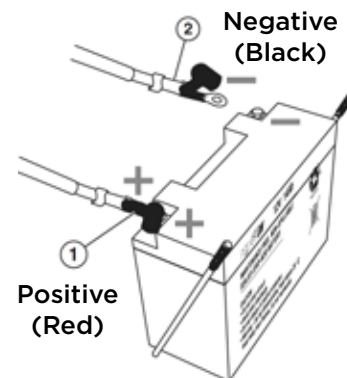
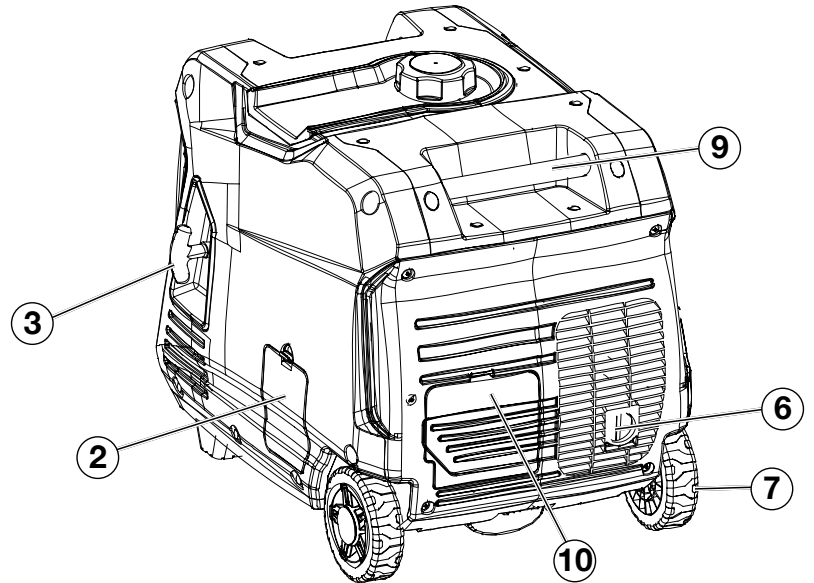
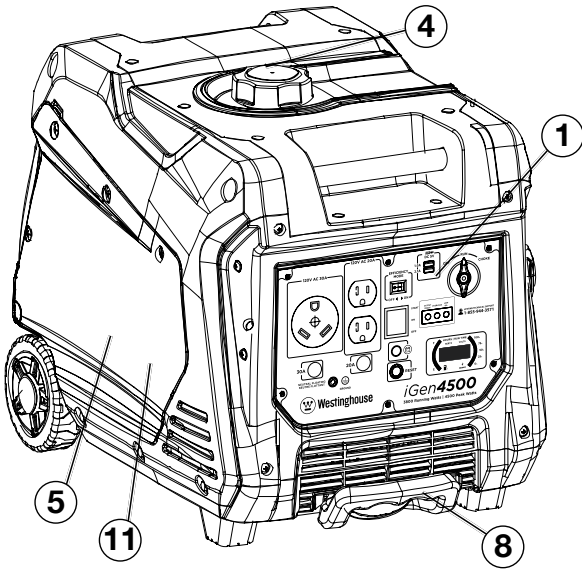

Figure 2: Installing Battery Leads

NOTE: The electric start generator is equipped with a battery charging feature. Once the engine is running, a small charge is supplied to the battery via the battery cables and will slowly recharge the battery.

FEATURES

BASIC INVERTER FEATURES iGen4500



- ① **Control Panel:** Contains the reset breaker, outlets and warning lights.
- ② **Oil Access Cover:** Remove the cover to access the oil fill/drain plug.
- ③ **Recoil Handle:** Pull to manually start the engine.
- ④ **Fuel Cap:** Close until clicking sound is heard.
- ⑤ **Engine Service Panel:** Remove the panel to access the engine, choke, air filter, spark plug and float bowl for maintenance.
- ⑥ **Muffler and Spark Arrestor:** Avoid contact until the engine is cooled down. The spark arrestor prevents sparks from exiting the muffler. It must be removed for servicing.

- ⑦ **Roller Board Wheels:** For easy portability.
- ⑧ **Telescoping Handle:** Extends and retracts for easy access.
- ⑨ **Carry Handles:** Built in handles to allow for easy pick up.
- ⑩ **Battery Access Panel:** Easy access to battery.
- ⑪ **Automatic Choke:** Unit will automatically set choke for electric and manual start (if battery is dead or disconnected you have to set choke manually)

FEATURES

CONTROL PANEL FEATURES iGen4500

- ① **120-Volt, 20-Amp Duplex Outlet (NEMA 5-20R):** The outlet is capable of carrying a maximum of 20 amps.
- ② **120-Volt 30 Amp TT-30 Outlet:** Travel Trailer outlet can supply a maximum of 30 amps and 120 volts.
- ③ **20-Amp Circuit Breakers:** Each circuit breaker limits the current that can be delivered through the 120-volt duplex outlets to 20amps.
- ④ **30-Amp Circuit Breakers:** Each circuit breaker limits the current that can be delivered through the 120-volt TT-30 outlets to 30amps.
- ⑤ **USB Duplex:** 5V DC USB outlets that come with 1 and 2.1 amp rating.
- ⑥ **Reset Breaker:** If the inverter is overloaded, the reset breaker will trip. The engine will continue to run, but there will be no output from the inverter. Unplug the devices and reduce the load. Push in the reset breaker to reset it.
- ⑦ **Efficiency Mode Switch:** When turned to the ON position, the engine will sense the load needed and run at a slower RPM to save fuel.
- ⑧ **Ground Terminal:** The ground terminal is used to externally ground the inverter.
- ⑨ **LED Data Center:** Displays remaining run time (F), power output in kW (P), fuel level in liters (L) and voltage (V).

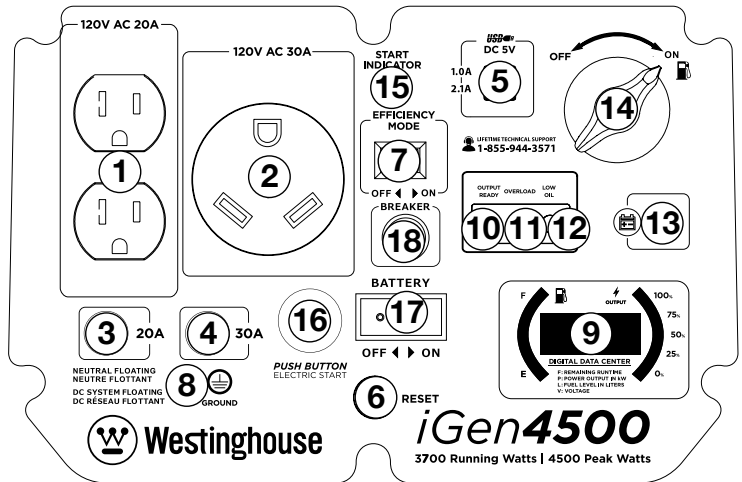
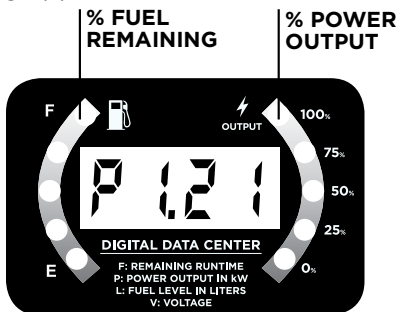

- ⑩ **Output Ready LED:** Indicates the inverter is ready to be used.
- ⑪ **Overload LED:** Indicates that the inverter is overloaded.
- ⑫ **Low Oil LED:** Indicates low oil level.
- ⑬ **Battery Charging Port:** Used to charge battery when unit is off.
- ⑭ **Fuel Control Switch:** Allows fuel to flow to the engine.
- ⑮ **Start Indicator:** Indicates that power is on, light will remain lit the whole time the unit is on.
- ⑯ **Push Button Automated Start:** Push once to automatically start the engine. Push again to stop the engine.
- ⑰ **Battery Switch:** Turns battery on and off. Must be on before electric start.
- ⑱ **Main Breaker:** The main circuit breaker controls total output of all outlets to protect the generator.

AUTOMATIC ROTATING DATA NUMBER DISPLAY



Remaining Run Time: Displays time remaining with current fuel level and power output. Does not display lifetime hours.



Power Output: Displays electrical power output to receptacles in kilowatts.



Fuel level: Displays current fuel level in liters.



Voltage: Displays current voltage output of generator.

OPERATION

BEFORE STARTING THE INVERTER



BEFORE STARTING THE INVERTER, REVIEW SAFETY SECTION STARTING ON PAGE 4.

Location Selection – Before starting the inverter, avoid exhaust and location hazards by verifying:

- You have selected a location to operate the inverter that is outdoors and well ventilated.
- You have selected a location with a level and solid surface on which to place the inverter.
- You have selected a location that is at least 6 feet (1.8 m) away from any building, other equipment or combustible material.
- If the inverter is located close to a building, make sure it is not located near any windows, doors and/or vents.

⚠ DANGER

Using a generator indoors **CAN KILL YOU IN MINUTES.** Generator exhaust contains carbon monoxide. This is a poison you cannot see or smell.



NEVER use inside a home or garage, **EVEN IF** doors and windows are open.



Only use **OUTSIDE** and far away from windows, doors, and vents.

Avoid other generator hazards. **READ MANUAL BEFORE USE.**

⚠ WARNING



Always operate the inverter on a level surface. Placing the inverter on non level surfaces can cause the inverter to tip over, causing fuel and oil to spill. Spilled fuel can ignite if it comes in contact with an ignition source such as a very hot surface.

NOTICE

Only operate the inverter on a solid, level surface. Operating the inverter on a surface with loose material such as sand or grass clippings can cause debris to be ingested by the inverter that could:

- Block cooling vents
- Block air intake system

Weather – Never operate your inverter outdoors during rain, snow or any combination of weather conditions that could lead to moisture collecting on, in or around the generator.

Dry Surface – Always operate the inverter on a dry surface free of any moisture.

No Connected Loads – Make sure the inverter has no connected loads before starting it. To ensure there are no connected loads, unplug any electrical extension cords that are plugged into the control panel receptacles.

NOTICE

Starting the inverter with loads already applied to it could result in damage to any appliance being powered off the inverter during the brief start-up period.

Grounding the iGen Inverters

Consult with your local municipalities for your grounding codes.

⚠ WARNING



Be sure the inverter is properly connected to earth ground before operating.

High Altitude Operation

Engine power is reduced the higher you operate above sea level. Output will be reduced approximately 3.5% for every 1000ft of increased altitude from sea level. This is a natural occurrence and cannot be adjusted by engine. Increased exhaust emissions can also result due to increased fuel mixture. Other issues include hard starting, increased fuel consumption and spark plug fouling.

High Altitude Carburetor Kit Part Number: 140540

⚠ WARNING



Do not rest inverter on exhaust panel. Do not move Generator while it is on. The inverter will be damaged if operated in this manner.

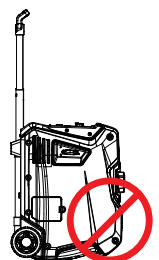

OPERATION

POWERCORD

Using Extension Cords

Westinghouse Portable Power assumes no responsibility for the content within this table. The use of this table is the responsibility of the user only. This table is intended for reference only. The results produced by using this table are not guaranteed to be correct or applicable in all situations as the type and construction of cords are highly variable. Always check with local regulations and a licensed electrician prior to installing or connecting an electrical appliance

Extension Cord Wire Gauge Size

AMPS	LENGTH OF EXTENSION CORD (ft)								
	10	20	30	40	50	60	80	100	120
5	20	18	16	14	12	12	10	10	8
10	18	16	14	12	12	10	10	8	8
15	16	14	12	12	10	10	8	8	6
20	14	12	12	10	10	8	8	6	6
25	12	12	10	10	8	8	6	6	6
30	12	10	10	8	8	6	6	6	6
35	10	10	8	8	6	6	6	6	6

INVERTER PARALLELING OPERATION

DANGER

Never connect the paralleling cord to the inverters with the inverters running. The inverters must not be running and both the paralleling cord switches must be off when connecting the cords.

WARNING

Do not attempt to parallel the Westinghouse inverter with any other manufacturers' inverters. Do not use the paralleling cord for any application other than inverter paralleling. Do not use this cord on other manufacturers' inverters.

Always ensure that both ends of the paralleling cord are switched off before connecting the inverters.

INVERTER PARALLELING OPERATION

1. Using only the Westinghouse paralleling cord with both cord switches set to **OFF (O)**, connect one male plug to one inverter and connect the remaining plug into the other inverter. Either of the receptacles on the inverters can be used.
2. Start one of the inverters and wait until the ready light is on.
3. Turn both cord switches to **ON (I)**.
4. Start the remaining inverter; wait until the ready light is on before connecting the load.
5. When power is present, a light will illuminate in the three-prong plug that is plugged into the inverter.
6. To stop the inverters, unplug all connected loads, turn both cord switches to **OFF (O)** and unplug the cord on each inverter.
7. If during operation the inverters' output is stopped due to overloading, reduce the connected load by unplugging appliances, and then push the reset button and restart the inverter. When the ready light is on, the load can be reconnected.

OPERATION

INITIAL OIL FILL



BEFORE ADDING ENGINE OIL, REVIEW SAFETY SECTION STARTING ON PAGE 4.

NOTICE

Engine oil must be added when the inverter is on a flat, level surface, or an inaccurate reading may result. Do not overfill. If the engine is overfilled with oil, it can cause serious engine damage.

1. Unclip and remove the oil service panel to access the oil fill/drain plug (see Figure 3).

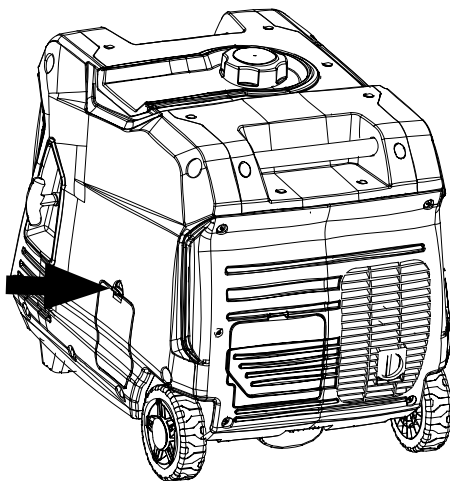

Figure 3: Oil Service Panel

2. Clean area around oil fill/drain plug and remove plug.
3. Using the supplied funnel and oil, pour the entire bottle of oil into the engine. See correct oil level in Figure 4 below.

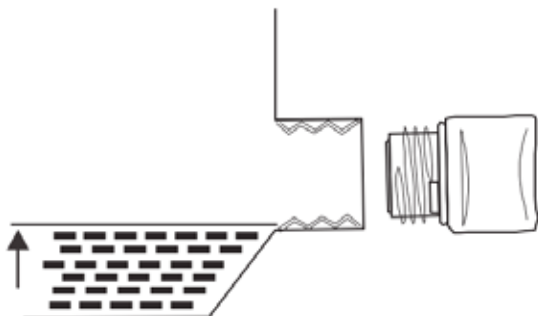

Figure 4: Engine Oil Correct Level

4. Do not overfill, if oil level is too high, oil will drain out through the fill plug.

ADDING/CHECKING ENGINE FLUIDS AND FUEL



BEFORE ADDING/CHECKING ENGINE FLUIDS AND FUEL, REVIEW SAFETY SECTION STARTING ON PAGE 4.

DANGER



Filling the fuel tank with gasoline while the inverter is running can cause gasoline to leak and come in contact with hot surfaces that can ignite the gasoline.

Before starting the inverter, always check the level of:

- Engine oil
- Gasoline in the fuel tank

Once the inverter is started and the engine gets warm, it is not safe to add gasoline to the fuel tank or engine oil to the engine while the engine is running or the engine and muffler are hot.

CHECKING AND / OR ADDING ENGINE OIL

WARNING



Internal pressure can build in the engine crankcase while the engine is running. Removing the oil fill plug/dipstick while the engine is hot can cause extremely hot oil to spray out of the crankcase and can severely burn skin. Allow engine oil to cool for several minutes before removing the oil fill plug/dipstick.

The unit as shipped does not contain oil in the engine. You must add engine oil before starting the inverter for the first time. See *Initial Oil Fill* for instructions on checking engine oil level and the procedure for adding engine oil.

NOTICE

The engine does not contain engine oil as shipped. Attempting to start the engine without adding engine oil will permanently damage internal engine components.

The engine is equipped with a low oil shutdown switch. If the oil level becomes low, the engine may shut down and not start until the oil is filled to the proper level.

The owner of the inverter is responsible to ensure the proper oil level is maintained during the operation of the generator. Failure to maintain the proper oil level can result in engine damage.

OPERATION

ADDING GASOLINE TO THE FUEL TANK

⚠ WARNING



Never refuel the inverter while the engine is running.



Always turn the engine off and allow the inverter to cool before refueling.

⚠ CAUTION



Avoid prolonged skin contact with gasoline. Avoid prolonged breathing of gasoline vapors.

Required Gasoline – Only use gasoline that meets the following requirements:

- Unleaded gasoline only
- Gasoline with maximum 10% ethanol added
- Gasoline with an 87 octane rating or higher

Filling the Fuel Tank – Follow the steps below to fill the fuel tank:

1. Shut off the inverter.
2. Allow the inverter to cool down so all surface areas of the muffler and engine are cool to the touch.
3. Move the inverter to a flat surface.
4. Clean area around the fuel cap.
5. Remove the fuel cap by rotating counterclockwise.

NOTICE

Do not overfill the fuel tank. Spilled fuel will damage some plastic parts.

6. Slowly add gasoline into the fuel tank. Be very careful not to overfill the tank. The gasoline level should NOT be higher than the red ring (see Figure 5).
7. Install the fuel cap by rotating clockwise.



Figure 5: Maximum Gasoline Fill Level

STARTING THE INVERTER



BEFORE STARTING THE INVERTER, REVIEW SAFETY SECTION STARTING ON PAGE 4.

For proper starting and operation of the inverter, make sure you review the inverter features and their descriptions starting on page 7.

Before attempting to start the inverter, verify the following:

- The engine is filled with engine oil (see Figure 4: *Engine Oil Correct Level* on page 11).
- The inverter is situated in a proper location (see *Location Selection* on page 9).
- The inverter is on a dry surface (see *Weather and Dry Surface* on page 9).
- All loads are disconnected from the inverter (see *No Connected Loads* on page 9).
- The inverter is properly grounded (see *Grounding the Inverter* on page 9)

⚠ DANGER



Never use the inverter in a location that is wet or damp. Never expose the inverter to rain, snow, water spray or standing water while in use. Protect the inverter from all hazardous weather conditions. Moisture or ice can cause a short circuit or other malfunction in the electrical circuit.



Never operate the inverter in an enclosed area. Engine exhaust contains carbon monoxide. Only operate the inverter outside and away from windows, doors and vents.

OPERATION

ELECTRIC START

1. Check oil levels (see *Initial Oil Fill* on page 11)
2. Make sure nothing is plugged into any of the outlets.
3. Make sure battery is connected (see *Hooking Up the Battery* on page 6).
4. Make sure the circuit breakers are properly set (see Figure 6).

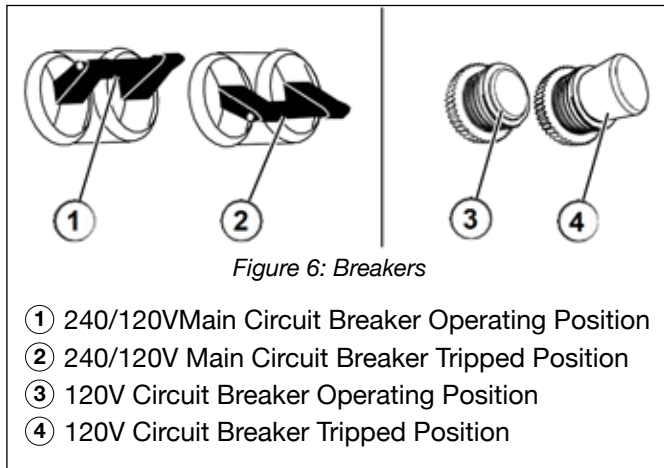

Figure 6: Breakers

- ① 240/120V Main Circuit Breaker Operating Position
- ② 240/120V Main Circuit Breaker Tripped Position
- ③ 120V Circuit Breaker Operating Position
- ④ 120V Circuit Breaker Tripped Position

5. Turn the Fuel Control Switch to the **ON** position (see Figure 7).

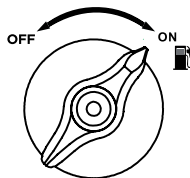

Figure 7: Turn Fuel Switch to ON Position

6. Turn battery switch **ON**.
7. Push and hold the engine start push button for 1 second and release (see Figure 8). The engine will automatically set the choke and begin the start sequence.

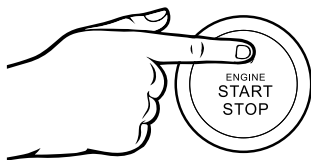

Figure 8: Electric Start Button - PUSH

Note: If the engine fails to start after 5 seconds, release the button. Let the generator sit idle for 15 seconds and then repeat step 7. If the cranking speed drops after each unsuccessful attempt, then the battery may not be adequately charged.

8. Plug in electronic devices.

MANUAL START

1. Check oil levels (see *Initial Oil Fill* on page 11)
2. Make sure nothing is plugged into any of the outlets.
3. Make sure battery is connected (see *Hooking Up the Battery* on page 6).
4. Make sure the circuit breakers are properly set (see Figure 6).
5. Turn the Fuel Control Switch to the **ON** position (see Figure 7).
6. Turn the battery switch **ON**.
7. Firmly grasp and pull the recoil handle slowly until you feel increased resistance. At this point, apply a rapid pull while pulling out from the inverter (see Figure 9).

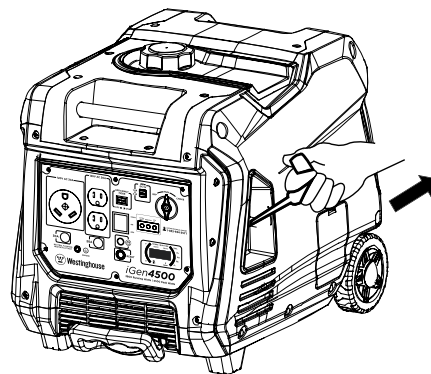

Figure 9: Pull the Recoil Handle out from Inverter

8. Plug in electronic devices.

WIRELESS REMOTE START

Note: To pair your remote to your iGen4500 press and hold the start button for 10 seconds the button will flash. At that point you can press either button on your remote and you have completed the pairing process.

1. Check oil levels (see *Adding Engine Oil* page 11)
2. Battery must be connected for auto choke to work.
3. Make sure the circuit breakers are properly set (see Figure 6).
4. Confirm that the Fuel Control Switch is in the **ON** position (see Figure 7).
5. Push the **START** icon on the wireless remote. (see Figure 10).

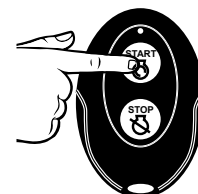

Figure 10: Wireless Remote - START

OPERATION

STOPPING THE INVERTER

Normal Operation

During normal operation, use the following steps to stop your inverter:

1. Remove any connected loads from the control panel receptacles.
2. Allow the inverter to run at “no load” to reduce and stabilize engine and alternator temperatures.
3. Move the Fuel Control Switch to the **OFF** position, press “Stop” on remote start key fob, or press the push button start once (see Figure 11).

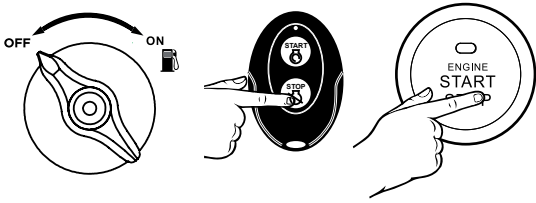

Figure 11: Stopping Generator

During an Emergency

If there is an emergency and the inverter must be stopped quickly, move the Fuel Control Switch to the **OFF** position immediately.

USING EFFICIENCY MODE

The inverter is equipped with an efficiency mode switch to minimize fuel consumption. In efficiency mode, the inverter will sense the load and adjust the engine RPM to the current load requirements. Efficiency mode should be used only after the inverter has been warmed up to operating temperature.

1. To turn on the efficiency mode, press the switch to the **ON** position).
2. If no load is present, the inverter RPM will drop down to an idle speed.
3. As a load is applied, the inverter will sense the load and engine RPM will increase according to the load applied.
4. To run the inverter at maximum power and RPM, press the efficiency mode switch to the **OFF** position.

RESETTING THE RESET BREAKER

The inverter will trip the breaker and automatically disconnect from the load when the controls sense a predetermined overload condition. The inverter engine will continue to run, but there will not be any electrical output.

1. Turn off all devices and unplug them from the inverter.
2. Determine the wattage required from the devices being powered by the inverter. Make sure the wattage required does not exceed the maximum output of the inverter.

3. Press in the reset breaker to reset it.
4. Plug the devices in to the inverter.
5. Turn on the devices as needed.

PROGRAMMING THE GENERATOR FOR REMOTE START

NOTICE

The key fob included with the generator should come already paired with the unit. If it does not you can follow the directions below to reconnect. If your unit was shipped without a key fob please contact our customer support team.

The generator can be started remotely from up to a maximum of 109 yards (100 M) away using the remote start key fob with new, fully charged batteries in the key fob. As the batteries' state of charge in the key fob reduces, the distance to start the generator will also reduce.

If the key fob is replaced or needs to be reconnected, you will need to go through this procedure with the new fob.

1. Turn the battery switch to the **ON** position.
2. Press and hold the electric start button on the control panel of the generator for 10s, then let go, and the start indicator light will flash green.

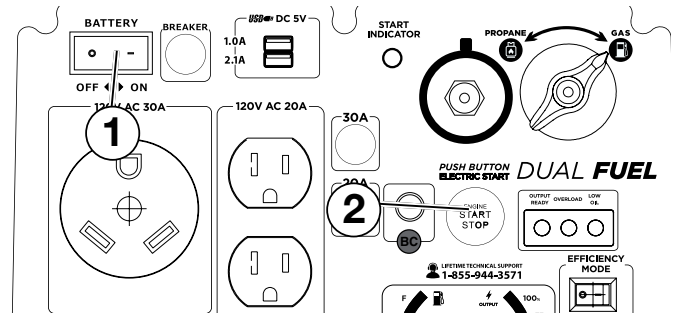

3. Press the start button on remote fob, and it will pair with generator automatically. Then the start indicator light on the generator will stop flashing.
4. Start the unit.

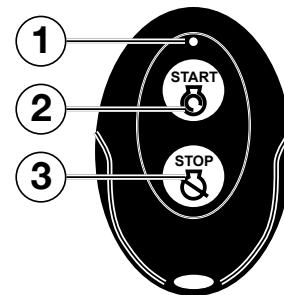

Remote Start Key Fob

1 - Pairing Indicator light
2 - Start Button | 3 - Stop Button

MAINTENANCE



BEFORE PERFORMING MAINTENANCE ON THE INVERTER, REVIEW THE SAFETY SECTION STARTING ON PAGE 4, AS WELL AS THE FOLLOWING SAFETY MESSAGES.

⚠ WARNING	
	Avoid accidentally starting the inverter during maintenance by removing the spark plug boot from the spark plug. For electric start inverters, also disconnect the battery cables from the battery (disconnect the black negative (-) cable first) and place the cables away from the battery posts to avoid arcing.
	Allow hot components to cool to the touch prior to performing any maintenance procedure.
	Internal pressure can build in the engine crankcase while the engine is running. Removing the oil fill plug/dipstick while the engine is hot can cause extremely hot oil to spray out of the crankcase and can severely burn skin. Allow engine oil to cool for several minutes before removing the oil fill plug/dipstick.
	Always perform maintenance in a well-ventilated area. Gasoline fuel and fuel vapors are extremely flammable and can ignite under certain conditions.

⚠ CAUTION	
	Avoid skin contact with engine oil or gasoline. Prolonged skin contact with engine oil or gasoline can be harmful. Frequent and prolonged contact with engine oil may cause skin cancer. Take protective measures and wear protective clothing and equipment. Wash all exposed skin with soap and water.

⚠ WARNING	
	Failure to perform periodic maintenance or not following maintenance procedures can cause the inverter to malfunction and could result in death or serious injury.

NOTICE	
Periodic maintenance intervals vary depending on inverter operating conditions. Operating the inverter under severe conditions, such as sustained high-load, high-temperature, or unusually wet or dusty environments, will require more frequent periodic maintenance. The intervals listed in the maintenance schedule should be treated only as a general guideline.	

Following the maintenance schedule is important to keep the inverter in good operating condition. The following is a summary of maintenance items by periodic maintenance intervals.

TABLE 1: MAINTENANCE SCHEDULE - OWNER PERFORMED

Maintenance Item	Before Every Use	After First 20 Hours or First Month of Use	After 50 Hours of Use or Every 6 Months	After 100 Hour of Use or Every 6 Months	After 300 Hours of Use or Every Year
Engine Oil	Check Level	Change	Change	-	-
Cooling Features	Check/Clean	-	-	-	-
Air Filter	Check	-	Clean*	-	Replace
Spark Plug	-	-	-	Check/Clean	Replace
Spark Arrestor	-	-	-	Check/Clean	-

*Service more frequently if operating in dry and dusty conditions

MAINTENANCE

ENGINE OIL MAINTENANCE

Engine Oil Specification

1. Only use the engine oil specified in Figure 12.
2. Only use 4-stroke/cycle engine oil. **NEVER USE 2-STROKE/CYCLE OIL.** Synthetic oil is an acceptable substitute for conventional oil.

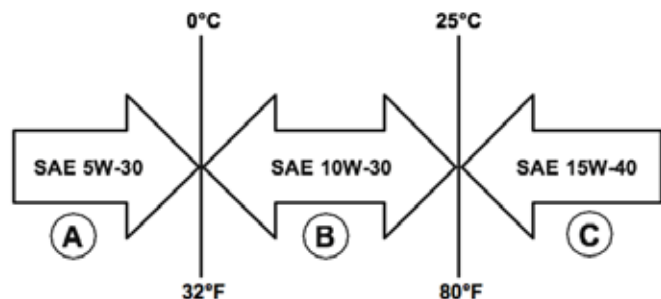

Figure 12: Recommended Oil

CHECKING ENGINE OIL

NOTICE

Always maintain proper engine oil level. Failure to maintain proper engine oil level could result in severe damage to the engine and/or shorten the life of the engine.

Always use the specified engine oil. Failure to use the specified engine oil can cause accelerated wear and/or shorten the life of the engine.

Engine oil level should be checked before every use.

1. Always operate or maintain the inverter on a flat surface.
2. Stop engine if running.
3. Let engine sit and cool for several minutes (allow crankcase pressure to equalize).
4. Remove the oil service panel to access the oil fill/drain plug (see Figure 3 on page 11).
5. With a damp rag, clean around the oil fill/drain plug.
6. Remove the oil fill/drain plug.
7. Check oil level: When checking the engine oil, remove the oil fill/ drain plug (see Figure 4 on page 11).
 - The oil level is acceptable if oil is visible at the bottom of the threads of the oil fill plug.
 - If oil level is low, add to the correct level using the supplied oil fill bottle. Do not overfill the oil crankcase.

NOTICE

Engine oil must always be checked and added when the inverter is on a flat, level surface, or an inaccurate reading may result, causing serious engine damage.

ADDING ENGINE OIL

1. Always operate or maintain the inverter on a flat surface.
2. Stop engine if running.
3. Let engine sit and cool for several minutes (allow crankcase pressure to equalize).
4. Remove the engine service panel to gain access to the oil fill/drain plug.
5. Thoroughly clean around the oil fill/drain plug.
6. Remove the oil fill/drain plug.
7. Select the proper engine oil as specified in Figure 12.
8. Using the supplied oil funnel, slowly add engine oil to the engine. Stop frequently to check the oil level and avoid overfilling.

CHANGING ENGINE OIL

1. Stop the engine.
2. Let engine sit and cool for several minutes (allow crankcase pressure to equalize).
3. Remove the oil service panel to gain access to the oil fill/drain plug.
4. Place oil pan (or suitable container) under the rubber plug just below the oil fill/drain cap.
5. Unscrew the rubber plug so the oil can drain out the bottom of the generator.
6. Using a 10mm wrench, remove the oil drain bolt (pictured below) to allow oil to drain.

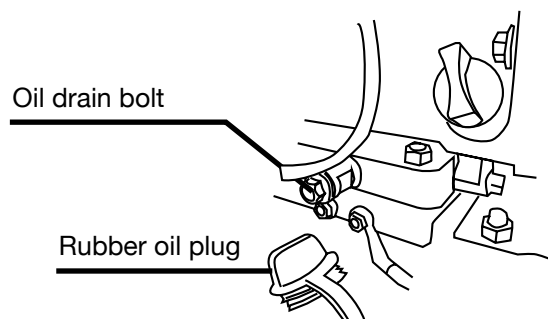

7. Allow oil to completely drain, dispose of used engine oil properly.
8. Fill crankcase with oil following the steps outlined in *Adding Engine Oil* above and tighten oil plug.
9. Use a rag and remove access oil at the bottom of the unit and replace the rubber oil cap as well as the oil drain bolt. Replace access panel.

NOTICE

Never dispose of used engine oil by dumping the oil into a sewer, on the ground, or into groundwater or waterways. Always be environmentally responsible. Follow the guidelines of the EPA or other governmental agencies for proper disposal of hazardous materials. Consult local authorities or reclamation facility.

MAINTENANCE

AIR FILTER MAINTENANCE

⚠ WARNING



Never use gasoline or other flammable solvents to clean the air filter. Use only household detergent soap to clean the air filter.

Cleaning the Air Filter

The air filter must be cleaned after every 50 hours of use or 3 months (frequency should be increased if inverter is operated in a dusty environment).

1. Turn off the inverter and let it cool for several minutes if running.
2. Remove the Engine Service Panel to gain access to the air filter (see Figure 13).

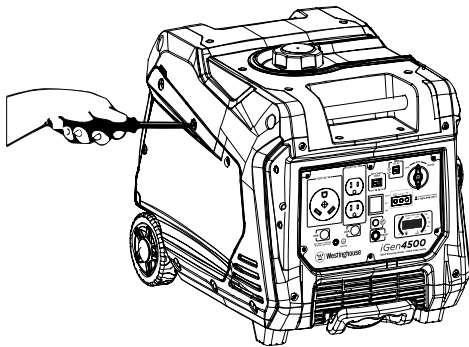

Figure 13: Remove Engine Service Panel

3. Turn the 2 knobs on the air cleaner to unlock the cover. Tip the cover down to access the foam element (see Figure 14).

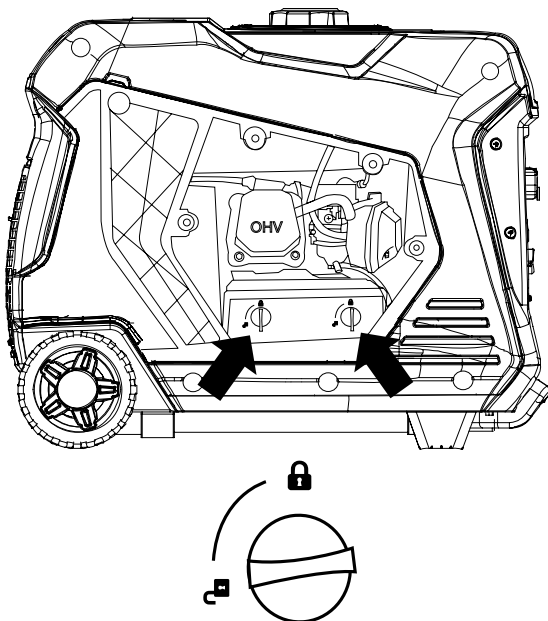

Figure 14: Unlock Air Filter Cover

4. Remove the foam element from the air cleaner housing.
5. Wash the foam air filter element by submerging the element in a solution of household detergent soap and warm water. Slowly squeeze the foam to thoroughly clean.

NOTICE

NEVER twist or tear the foam air filter element during cleaning or drying. Only apply slow but firm squeezing action.

6. Rinse in clean water by submerging the air filter element in fresh water and applying a slow squeezing action (see Figure 15).



Figure 15: Squeeze Air Filter

NOTICE

Never dispose of soap cleaning solution used to clean the air filter by dumping the solution into a sewer, on the ground, or into ground water or waterways. Always be environmentally responsible. Follow the guidelines of the EPA or other governmental agencies for proper disposal of hazardous materials. Consult local authorities or reclamation facility.

7. Dispose of used soap cleaning solution properly.
8. Dry the air filter element by again applying a slow firm squeezing action.
9. Return the air filter element to its position in the air cleaner housing.
10. Install the air cleaner cover, making sure the knobs lock into place.
11. Install the engine service panel.

MAINTENANCE

DRAINING THE FLOAT BOWL

1. Remove the Engine Service Panel to access the carburetor (see Figure 13 on page 17).
2. Locate the clear plastic hose from the float that is extending towards the bottom of the inverter, pull those hose outside the body and place a suitable container under it to catch the drained fuel (see Figure 16).

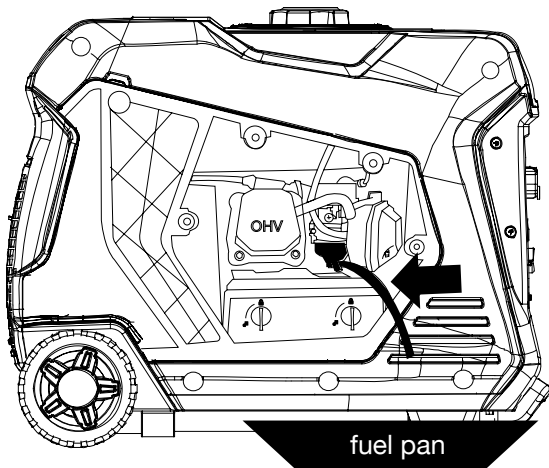

Figure 16: Fuel Drain Hose

3. Loosen the float bowl drain screw until fuel is seen draining from the float bowl (see Figure 17).

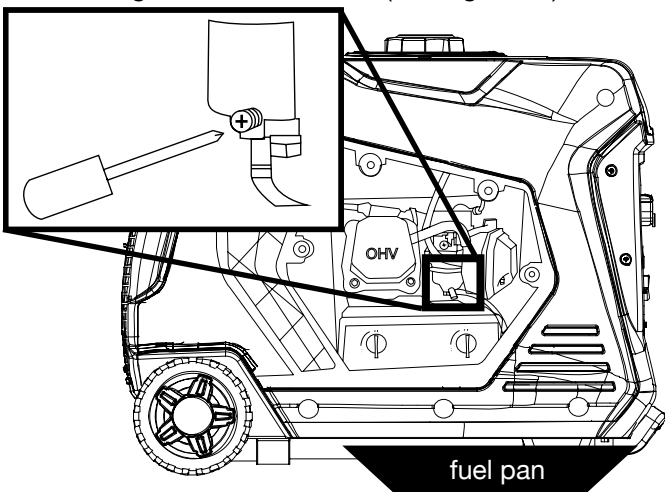

Figure 17: Loosen Float Bowl Screw

4. Allow fuel to drain into the container, and then tighten the float bowl drain screw.

NOTICE

Never dispose of fuel by dumping fuel into a sewer, on the ground, or into groundwater or waterways. Always be environmentally responsible. Follow the guidelines of the EPA or other governmental agencies for proper disposal of hazardous materials. Consult local authorities or reclamation facility.

5. Install the engine service panel.

SPARK PLUG MAINTENANCE

The spark plug must be checked and cleaned after every 100 hours of use or 6 months and must be replaced after 300 hours of use or every year.

1. Stop the inverter and let it cool for several minutes if running.
2. Move the inverter to a flat, level surface.
3. Remove the Engine Service Panel to gain access to the spark plug (see Figure 13 on page 17).
4. Remove the spark plug cover by firmly pulling the metal spark plug boot directly away from the engine (see Figure 18).

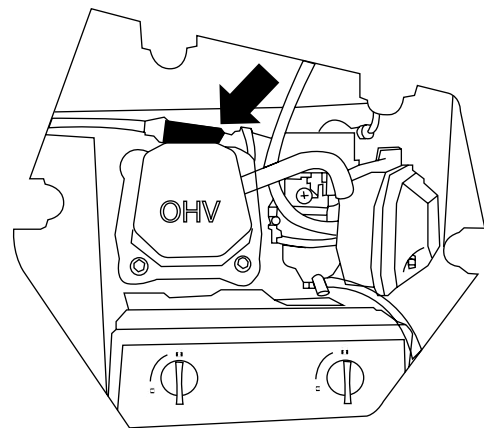

Figure 18: Pull off Spark Plug Cover

NOTICE

Never apply any side load or move the spark plug laterally when removing the spark plug. Applying a side load or moving the spark plug laterally may crack and damage the spark plug boot.

5. Clean area around the spark plug.
6. Using the spark plug socket wrench provided, remove the spark plug from the cylinder head (see Figure 19).

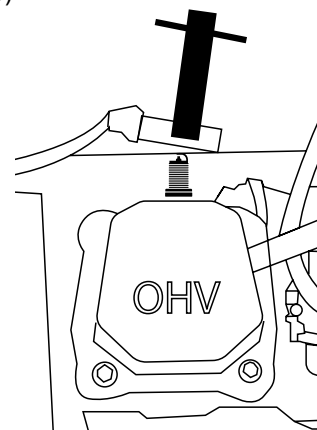
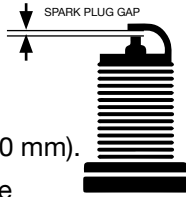

Figure 19: Remove Spark Plug

MAINTENANCE

Spark Plug Maintenance - Continued from page 18

7. Place a clean rag over the opening created by the removal of the spark plug to make sure no dirt can get into the combustion chamber.
8. Inspect the spark plug for:
 - Cracked or chipped insulator
 - Excessive wear
 - Spark plug gap of 0.032 in. (0.80 mm).



If the spark plug fails any one of the conditions listed above, replace the plug.

NOTICE

Only use the recommended spark plug. See chart below. Using a non-recommended spark plug could result in damage to the engine.

9. Install the spark plug by carefully following the steps outlined below:
 - a. Carefully insert the spark plug back into the cylinder head. Hand-thread the spark plug until it bottoms out.
 - b. Using the spark plug socket wrench provided, turn the spark plug to ensure it is fully seated.
 - c. Replace the spark plug boot, making sure the boot fully engages the spark plug's tip.
 - d. Install the spark plug access cover.

Recommended Spark Plug Replacement:

Westinghouse Model Number	Torch Spark plug	Champion	Bosch	Autolite
iGen4500	F7RTC	N9YC	W7DC	52

CLEANING THE SPARK ARRESTOR

Check and clean the spark arrestor after every 100 hours of use or 6 months.

1. Stop the inverter and let it cool for several minutes if running.
2. Move the inverter to a flat, level surface.
3. Remove the screws holding the muffler cover in place (see Figure 20).
4. Loosen the clamp holding the spark arrestor onto the muffler.
5. Slide the spark arrestor band clamp off the spark arrestor screen.

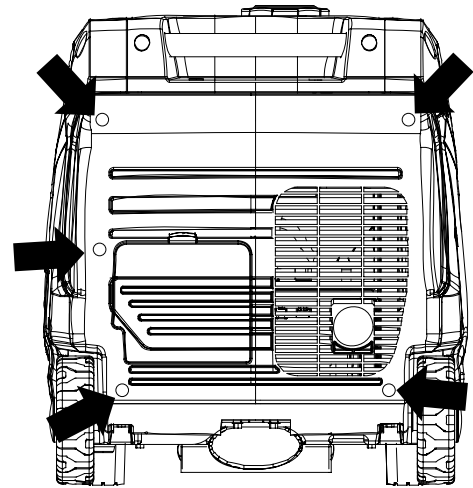

Figure 20: Remove Muffler Access Panel

6. Pull the spark arrestor screen off the muffler exhaust pipe.
7. Using a wire brush, remove any dirt and debris that may have collected on the spark arrestor screen.
8. If the spark arrestor screen shows signs of wear (rips, tears or large openings in the screen), replace the spark arrestor screen.
9. Install the spark arrestor components in the following order:
 - a. Place spark arrestor screen over the muffler exhaust pipe. Push on the screen until it fully bottoms out.
 - b. Place the spark arrestor band clamp over the screen and tighten with a flathead screwdriver
10. Replace the discharge gate.

CHECKING AND ADJUSTING VALVE LASH

⚠ CAUTION



Checking and adjusting valve lash must be done when the engine is cold.

1. Remove the rocker arm cover and carefully remove the gasket. If the gasket is torn or damaged, it must be replaced.
2. Remove the spark plug so the engine can be rotated more easily.
3. Rotate the engine to top dead center (TDC) of the compression stroke. Looking through the spark plug hole, the piston should be at the top.

MAINTENANCE

- Both the rocker arms should be loose at TDC on the compression stroke. If they are not, rotate the engine 360°.
- Insert a feeler gauge between the rocker arm and the push rod and check for clearance (see Figure 21). See table below for valve lash specifications

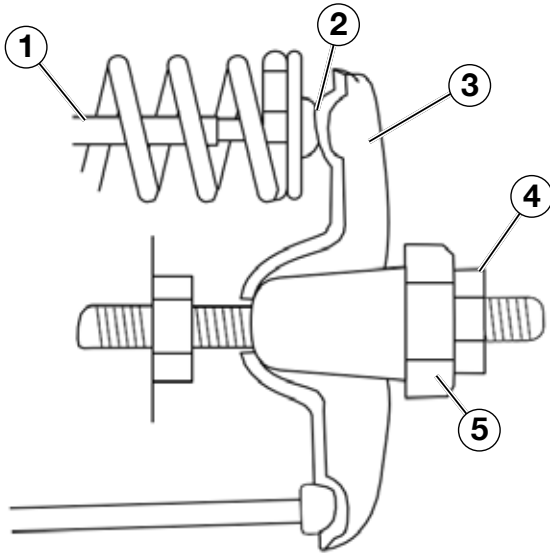

Figure 21
 (1) Push Rod, (2) Feeler Gauge Area
 (3) Rocker Arm, (4) Jam Nut, (5) Adjusting Nut

Standard Valve Lash

	Intake Valve	Exhaust Valve
Valve Lash	0.0035 ± 0.0043 in (0.09 ± 0.11 mm)	0.0043 ± 0.0051 in (0.11 ± 0.13 mm)
Bolt Torque	8-12N.m	8-12N.m

- If an adjustment is required, hold the adjusting nut and loosen the jam nut.
- Turn the adjusting nut to obtain the correct valve lash. When the valve lash is correct, hold the adjusting nut and tighten the jam nut to 106 in-lb (12 N•m).
- Recheck the valve lash after tightening the jam nut.
- Perform this procedure for both the intake and exhaust valves.
- Install the rocker arm cover, gasket and spark plug.

CLEANING THE INVERTER

It is important to inspect and clean the inverter before every use.

Clean All Engine Air Inlet and Outlet Ports – Make sure all engine air inlet and outlet ports are clean of any dirt and debris to ensure the engine does not run hot.

BATTERY SERVICE

To ensure the battery remains charged, the generator should be started every 2 to 3 months and run for a minimum of 15 minutes or a charger should be plugged into the generator and the generator should be charged overnight. Plug the cord from the charger into the charging port “⊕” on the generator. Plug the charger into a 110/120-volt AC outlet.

Battery Replacement

- Remove the spark plug wire from spark plug.
- Loosen the rubber strap holding the battery in place.
- Disconnect the black negative (-) battery cable from the battery first.
- Disconnect the red positive (+) battery cable second and remove the battery.

NOTICE

Dispose of the used battery properly according to the guidelines established by your local or state government.

- Install the new battery into the generator frame.
- Connect the red positive (+) battery cable to the battery first.
- Connect the black negative (-) battery cable to the battery second.
- Replace rubber strap to hold battery in place.
- Install the spark plug wire onto spark plug.

See below for the battery specification when replacing the battery.

After Market Battery Model	YT5AL
Volts	12
Amp Hr	5
Dimensions	4.63 in by 2.38 in by 5 in

MAINTENANCE

STORAGE

WARNING



Never store an inverter with fuel in the tank indoors or in a poorly ventilated area where the fumes can come in contact with an ignition source such as a: 1) pilot light of a stove, water heater, clothes dryer or any other gas appliance; or 2) spark from an electric appliance.

NOTICE

Gasoline stored for as little as 60 days can go bad, causing gum, varnish and corrosive buildup in fuel lines, fuel passages and the engine. This corrosive buildup restricts the flow of fuel, preventing an engine from starting after a prolonged storage period.

Proper care should be taken to prepare the inverter for any storage

1. Clean the inverter.
2. Siphon all gasoline from the fuel tank as best as possible.
3. Start the engine and allow the inverter to run until all the remaining gasoline in the fuel lines and carburetor is consumed and the engine shuts off.
4. Drain any remaining fuel from the float bowl. See *Draining the Float Bowl* on page 18.

5. Change the oil (see *Changing Engine Oil* on page 16).
6. Remove the spark plug (see *Spark Plug Maintenance* on page 18) and place about 1 tablespoon of oil in the spark plug opening. While placing a clean rag over the spark plug opening, slowly pull the recoil handle to allow the engine to turn over several times. This will distribute the oil and protect the cylinder wall from corroding during storage.
7. Replace the spark plug (see *Spark Plug Maintenance* on page 18).
8. Move the inverter to a clean, dry place for storage.

TROUBLESHOOTING

⚠ WARNING



Before attempting to service or troubleshoot the generator, the owner or service technician must first read the owner's manual and understand and follow all safety instructions. Failure to follow all instructions may result in conditions that can lead to voiding of the EPA certification or product warranty, serious personal injury, property damage or even death.

PROBLEM	POTENTIAL CAUSE	SOLUTION
Engine is running, but no electrical output.	1. Reset breaker is tripped.	1. Reset the reset breaker.
	2. The power cord's plug connector is not fully engaged in the inverter's outlet.	2. Verify plug connector is firmly engaged in the inverter's outlet.
	3. Faulty or defective power cord	3. Replace power cord.
	4. Faulty or defective electrical appliance	4. Try connecting a known good appliance to verify the inverter is producing electrical power.
Engine will not start or remain running while trying to start.	1. Inverter is out of gasoline.	1. Add gasoline to the inverter.
	2. Fuel flow is obstructed.	2. Inspect and clean fuel delivery passages.
	3. Dirty air filter	3. Check and clean the air filter.
	4. Low oil level shutdown switch is preventing the unit from starting.	4. Check oil level and add oil if necessary.
	5. Spark plug boot is not fully engaged with the spark plug tip.	5. Firmly push down on the spark plug boot to ensure the boot is fully engaged.
	6. Spark plug is faulty.	6. Remove and check the spark plug. Replace if faulty.
	7. Dirty/plugged spark arrestor	7. Check and clean the spark arrestor.
	8. Stale fuel	8. Drain fuel and replace with fresh fuel.
Inverter suddenly stops running.	1. Inverter is out of fuel.	1. Check fuel level. Add fuel if necessary.
	2. The low oil shut down switch has stopped the engine.	2. Check oil level and add oil if necessary.
	3. Too much load	3. Restart the inverter and reduce the load.
Engine runs erratic; does not hold a steady RPM.	1. Dirty air filter	1. Clean the air filter (see pages 24-25).
	2. Applied loads maybe cycling on and off	2. As applied loads cycle, changes in engine speed may occur; this is a normal condition.
	3. If trying 1-2 above does not solve the problem, the cause might be a fault in the inverter	3. Take the inverter to your nearest authorized service dealer.

iGen4500 SCHEMATIC

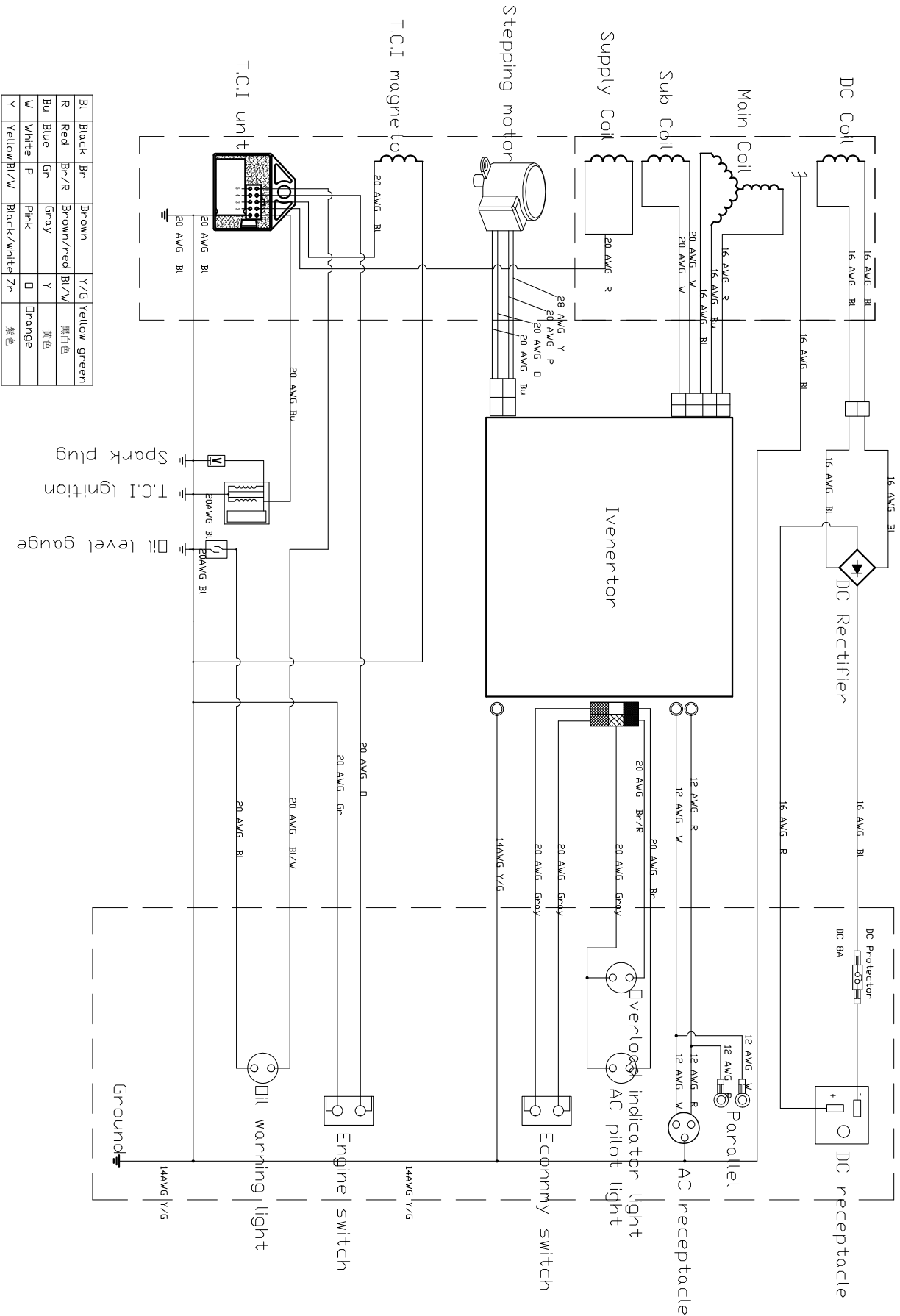

Bl	Black	Br	Brown	Y/G	Yellow green
R	Red	Br/R	Brown/red	Bl/W	黑白色
Bu	Blue	Gr	Gray	Y	黄色
W	White	P	Pink	D	Drange
Y	Yellow	Bl/W	Black/white	Zr	紫色

iGen4500 EXPLODED VIEW

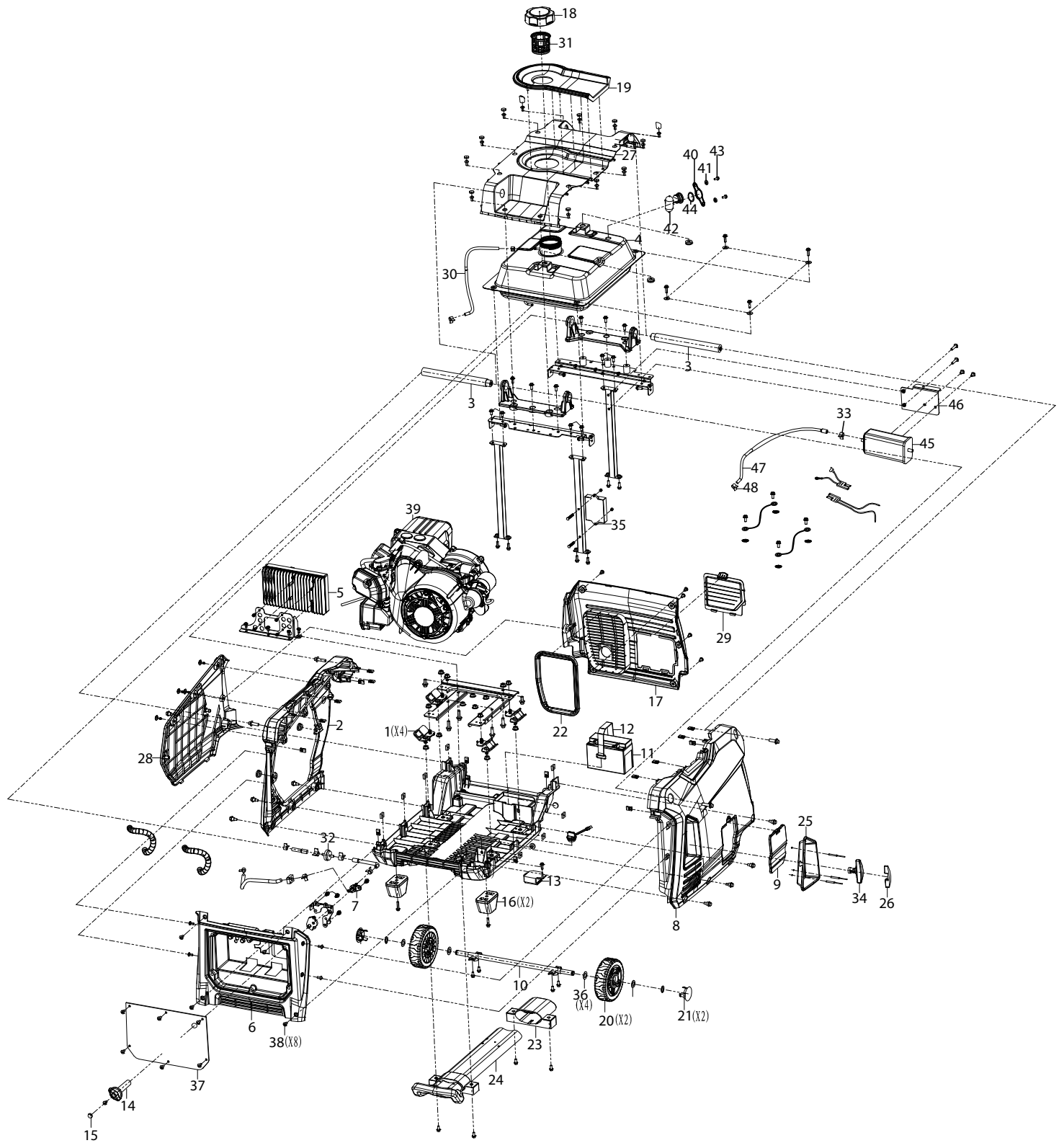

iGen4500 EXPLODED VIEW PART NUMBERS

No.	Part.	Description
1	100578	Damper
2	100562	Enclosure Side
3	100567	Lift Bar
4	150526	Fuel Tank
5	120538	Inverter Module
6	100569	Intake Grate
7	150535	Fuel Valve
8	100563	Enclosure Side
9	100568	Inspection Cover
10	100574	Axle Shaft
11	100579	Battery
12	100580	Battery Clamp
13	130526	Voltage Regulator
14	150531	Fuel Knob
15	150533	Plug
16	100570	Rubber Foot
17	100564	Discharge Grate
18	150530	Cap
19	150528	Splash Guard
20	100571	Wheel
21	100577	Axle Cover
22	100565	Rubber Boot
23	100573	Handle Bracket
24	100572	Handle Assembly
25	170513	Grip Cup
26	170515	Recoil Anchor

27	100561	Enclosure Top
28	100560	Side Panel
29	100566	Access Cover
30	150527	Vent Hose
31	150529	Strainer
32	150534	Fuel Filter
33	150536	Hose Clamp
34	170514	Recoil Grip
35	130525	Controller
36	100575	Washer
37	130524	Control Panel
38	150532	M6X16
39	180578	Engine Assembly
40	150542	Clamp
41	150543	Gasket
42	150540	Fuel Level Sensor
43	150544	Bolt
44	150541	Gasket
45	150537	Carbon Canister
46	150538	Canister Bracket
47	150539	Vent Hose
48	150508	Hose Clamp

iGen4500 ENGINE VIEW

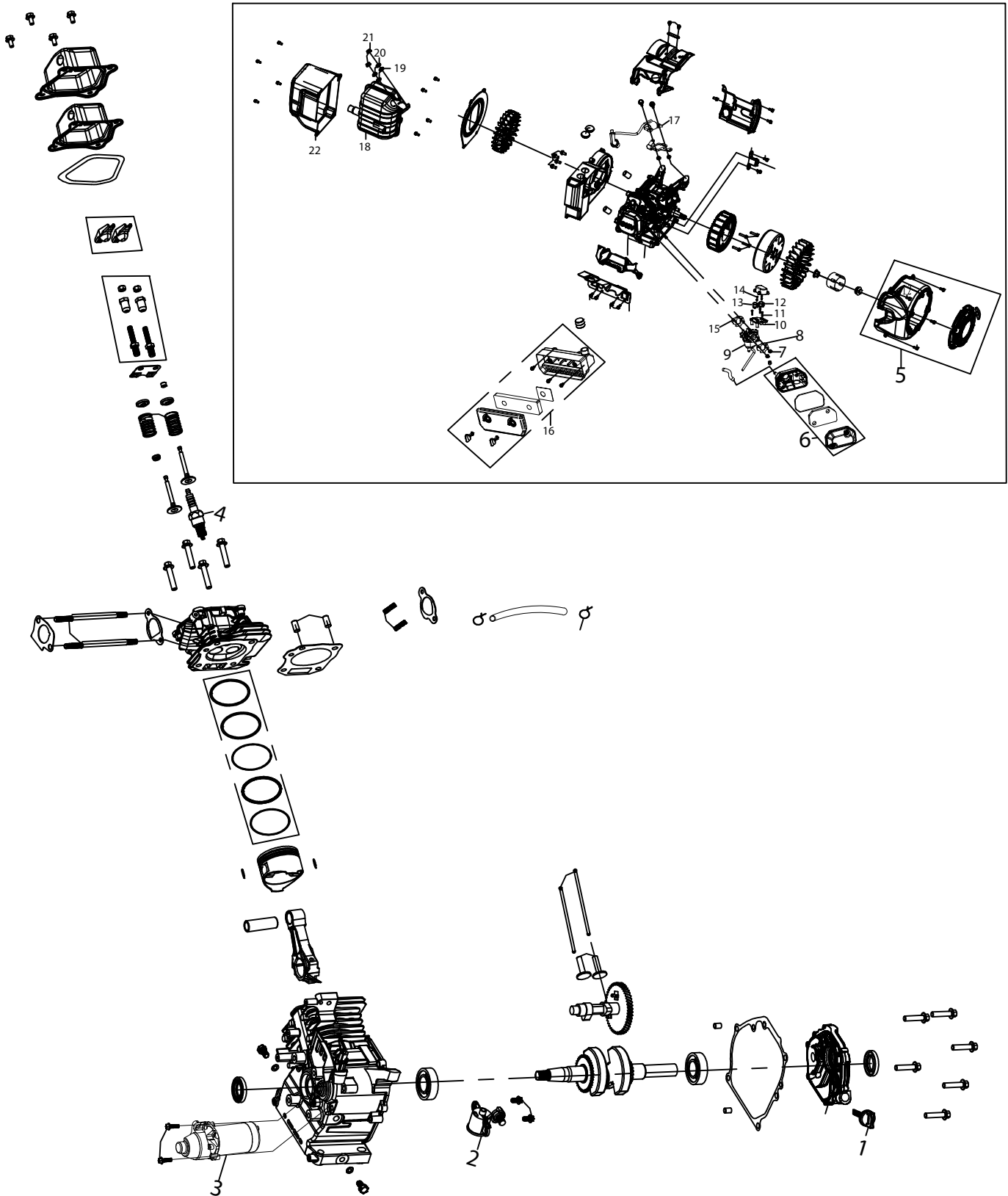

iGen4500 ENGINE VIEW PART NUMBERS

No.	Part.	Description
1	180581	Dip Stick
2	180582	Low Oil Switch
3	170516	Starter
4	180580	Spark Plug
5	170512	Recoil and Housing
6	160504	Air Box
7	100548	M6 Nut
8	140517	Gasket
9	140532	Carburetor Assembly
10	140531	Stepper Motor Bracket
11	140533	M4X25
12	140529	Stepper Motor
13	140530	Stepper Motor
14	140534	M4X6
15	140535	Spacer
16	160504	Air Cleaner Assembly
17	180579	Ignition Coil
18	110510	Muffler Assembly
19	110512	Washer
20	110502	Spring Washer
21	180524	M8 Nut
22	110511	Heat Shield



WestinghousePortablePower.com

Service Hotline: (855) 944-3571

**777 Manor Park Drive
Columbus, OH 43228**

™ & © 2016 Westinghouse Electric Corporation
© 2016 MWE Investments, LLC. All Rights Reserved.

Version 07.19.18KD