



Installation Manual

Generator Set with QSJ5.9G Engine and PowerCommand® 1.1/2.3 Control

C45 N6 (Spec A)
C50 N6 (Spec A)
C60 N6 (Spec A)
C70 N6 (Spec A)
C80 N6 (Spec A)
C100 N6 (Spec A)

California

Proposition 65 Warning

The engine exhaust from this product contains chemicals known to the State of California to cause cancer, birth defects, or other reproductive harm.

Table of Contents

| | |
|--|----|
| 1. IMPORTANT SAFETY INSTRUCTIONS | 1 |
| 1.1 Warning, Caution, and Note Styles Used in This Manual | 1 |
| 1.2 General Information | 1 |
| 1.3 Generator Set Voltage Is Deadly | 4 |
| 1.4 Fuel and Fumes Are Flammable | 5 |
| 1.5 Starting Batteries | 5 |
| 1.6 Batteries Can Explode | 5 |
| 1.7 Vented Batteries | 7 |
| 1.8 Moving Parts Can Cause Severe Personal Injury or Death | 7 |
| 1.9 Exhaust Gases Are Deadly..... | 7 |
| 1.10 The Hazards of Carbon Monoxide..... | 8 |
| 2. INTRODUCTION..... | 11 |
| 2.1 About This Manual..... | 11 |
| 2.2 Related Literature | 12 |
| 2.3 Before Installation | 13 |
| 2.4 Model Specifications | 13 |
| 3. PRE-INSTALLATION CONSIDERATIONS..... | 19 |
| 3.2 Installation Codes and Standards for Safety | 20 |
| 3.3 Required Items for Installation..... | 21 |
| 4. INSTALLATION..... | 23 |
| 4.1 Site Assessment and Preparation | 23 |
| 4.2 Fuel Selection and Fuel System Connection..... | 26 |
| 4.3 Engine Exhaust..... | 34 |
| 4.4 Electrical Connections | 35 |
| 5. STARTUP AND CONFIGURATION..... | 47 |
| 5.1 Time Setup | 47 |
| 5.2 Exercise Settings | 50 |
| 5.3 Brightness and Contrast | 54 |
| 5.4 History and About Menu | 56 |
| 5.5 Checklist | 58 |
| 5.6 Startup | 59 |
| 5.7 InPower Service Tool..... | 60 |
| 5.8 Disabling the AMF Feature | 60 |
| APPENDIX A. FUEL LINE SELECTION..... | 63 |
| A.0 Fuel System Pipe Sizing Introduction..... | 64 |
| A.1 Gas Pipe Sizing..... | 65 |
| APPENDIX B. OUTLINE AND SYSTEM DRAWINGS..... | 77 |

| | |
|---|-----|
| APPENDIX C. WIRING DIAGRAMS..... | 91 |
| APPENDIX D. SEISMIC REQUIREMENTS..... | 133 |
| D.1 Seismic Installation Instructions | 135 |

1 Important Safety Instructions

Save these instructions. This manual contains important instructions that should be followed during installation and maintenance of the generator set.

Safe and efficient operation can be achieved only if the equipment is properly operated and maintained. Many accidents are caused by failure to follow fundamental rules and precautions.

1.1 Warning, Caution, and Note Styles Used in This Manual

The following safety styles and symbols found throughout this manual indicate potentially hazardous conditions to the operator, service personnel, or equipment.

DANGER

Indicates a hazardous situation that, if not avoided, will result in death or serious injury.

WARNING

Indicates a hazardous situation that, if not avoided, could result in death or serious injury.

CAUTION

Indicates a hazardous situation that, if not avoided, could result in minor or moderate injury.

NOTICE

Indicates information considered important, but not hazard-related (e.g., messages relating to property damage).

1.2 General Information

This manual should form part of the documentation package supplied by Cummins Power Generation with specific generator sets. In the event that this manual has been supplied in isolation please contact your authorized dealer.

NOTICE

It is in the operator's interest to read and understand all warnings and cautions contained in the documentation relevant to the generator set operation and daily maintenance.

General Safety Precautions

WARNING

Hot Pressurized Liquid

Contact with hot liquid can cause severe burns.

Do not open the pressure cap while the engine is running. Let the engine cool down before removing the cap. Turn the cap slowly and do not open it fully until the pressure has been relieved.

WARNING

Moving Parts

Moving parts can cause severe personal injury.

Use extreme caution around moving parts. All guards must be properly fastened to prevent unintended contact.

WARNING

Toxic Hazard

Used engine oils have been identified by some state and federal agencies to cause cancer or reproductive toxicity.

Do not ingest, breathe the fumes, or contact used oil when checking or changing engine oil. Wear protective gloves and face guard.

WARNING

Electrical Generating Equipment

Incorrect operation and maintenance can result in severe personal injury or death.

Do not operate equipment when fatigued, or after consuming any alcohol or drug.

Make sure that only suitably trained and experienced service personnel perform electrical and/or mechanical service.

WARNING

Toxic Gases

Substances in exhaust gases have been identified by some state and federal agencies to cause cancer or reproductive toxicity.

Do not breathe in or come into contact with exhaust gases.

WARNING

High Noise Level

Generator sets in operation emit noise, which can cause hearing damage.

Wear appropriate ear protection at all times.

⚠ WARNING**Hot Surfaces**

Contact with hot surfaces can cause severe burns.

Wear appropriate PPE when working on hot equipment and avoid contact with hot surfaces.

⚠ WARNING**Toxic Hazard**

Ethylene glycol, used as an engine coolant, is toxic to humans and animals.

Wear appropriate PPE. Clean up coolant spills and dispose of used coolant in accordance with local environmental regulations.

⚠ WARNING**Combustible Liquid**

Ignition of combustible liquids is a fire or explosion hazard which can cause severe burns or death.

Do not store fuel, cleaners, oil, etc., near the generator set. Do not use combustible liquids like ether.

⚠ WARNING**Combustible Gases**

Generator sets in operation have combustible gases under pressure, which if ignited can cause eye and ear damage.

Wear appropriate eye and ear protection at all times.

⚠ WARNING**Combustible Gases**

Generator sets in operation have combustible gases under pressure, which if ignited can cause severe injury.

Do not operate the generator set with any doors open.

⚠ WARNING**Fire Hazard**

Materials drawn into the generator set, as well as accumulated grease and oil, are a fire hazard. Fire can cause severe burns or death.

Keep the generator set and the surrounding area clean and free from obstructions. Make sure the generator set is mounted in a manner to prevent combustible materials from accumulating under the unit.

⚠ WARNING***Automated Machinery***

Accidental or remote starting of the generator set can cause severe personal injury or death.

Isolate all auxiliary supplies and use an insulated wrench to disconnect the starting battery cables (negative [-] first).

NOTICE

Keep multi-class ABC fire extinguishers handy. Class A fires involve ordinary combustible materials such as wood and cloth. Class B fires involve combustible and flammable liquid fuels and gaseous fuels. Class C fires involve live electrical equipment. (Refer to NFPA No. 10 in applicable region.)

NOTICE

Before performing maintenance and service procedures on enclosed generator sets, make sure the service access doors are secured open.

NOTICE

Stepping on the generator set can cause parts to bend or break, leading to electrical shorts, or to fuel, coolant, or exhaust leaks. Do not step on the generator set when entering or leaving the generator set room.

1.3 Generator Set Voltage Is Deadly

- Generator set output connections must be made by a trained and experienced electrician in accordance with all applicable codes.
- This generator set and the public utility may only be connected to house circuits by means of the automatic transfer switch.

⚠ CAUTION

Improper connections can lead to electrocution of utility workers and damage to equipment. Make sure that the connections are installed properly by a trained technician.

- Use caution when working on live electrical equipment. Remove jewelry, and make sure clothing and shoes are dry. Stand on a dry wooden platform.

1.4 Fuel and Fumes Are Flammable

Fire, explosion, and personal injury or death can result from improper practices.

- Do not fill fuel tanks while the engine is running unless the tanks are outside the engine compartment. Fuel contact with hot engine or exhaust is a potential fire hazard.
- Do not permit any flame, cigarette, pilot light, spark, arcing equipment, or other ignition source near the generator set or fuel tank.
- Fuel lines must be adequately secured and free of leaks. Fuel connection at the engine should be made with an approved flexible line. Do not use copper piping on flexible lines as copper will become brittle if continuously vibrated or repeatedly bent.
- Make sure all fuel supplies have a positive shutoff valve.
- Make sure the battery area has been well-ventilated prior to servicing near it. Lead-acid batteries emit a highly explosive hydrogen gas that can be ignited by arcing, sparking, smoking, etc.

1.5 Starting Batteries

 **WARNING**

Toxic Hazard

The electrolyte in starting batteries is a dilute sulfuric acid that is harmful to the skin and eyes. It is also electrically conductive and corrosive.

Always:

- 1. Wear full eye protection and protective clothing;***
- 2. If the electrolyte contacts the skin, wash it off immediately with water;***
- 3. If the electrolyte contacts the eyes, flush them thoroughly and immediately with water and seek medical attention; and***
- 4. Wash spilled electrolyte down with an acid neutralizing agent. A common practice is to use a solution of one pound (500 grams) bicarbonate of soda (also known as baking soda or sodium bicarbonate) to one gallon (4 liters) of water.***
- 5. Continue to add the bicarbonate of soda solution until the evidence of reaction (that is, foaming) has stopped.***
- 6. Flush the resulting liquid with water and dry the area.***

1.6 Batteries Can Explode

Batteries can explode, causing severe skin and eye burns and can release toxic electrolytes.

⚠ WARNING**Combustible Gases**

Batteries can explode, causing severe skin and eye burns, and can release toxic electrolytes.

Do not dispose of the battery in a fire, because it is capable of exploding. Do not open or mutilate the battery.

⚠ WARNING**Electric Shock Hazard**

Batteries present the risk of high short circuit current.

Remove watches, rings, or other metal objects. Use tools with insulated handles.

NOTICE

Servicing of batteries must be performed or supervised by personnel knowledgeable of batteries and the required precautions. Keep unauthorized personnel away from batteries.

- Wear safety glasses.
- Do not smoke.
- To prevent arcing when disconnecting the battery:
 1. Press the Off switch from the display and then press the E-Stop button.
 2. Disconnect AC power from any battery chargers.
 3. Remove the negative (-) battery cable to prevent starting.
- To prevent arcing when reconnecting the battery:
 1. Reconnect the positive (+) cable.
 2. Reconnect the negative (-) cable.
 3. Reconnect the battery charger to AC power supply.
- When replacing the generator set battery, always replace it with a battery as specified in this manual.

1.7 Vented Batteries

 **WARNING**

Toxic Hazard

The electrolyte in vented batteries is a dilute sulfuric acid that is harmful to the skin and eyes. It is also electrically conductive and corrosive.

Always:

- 1. Wear full eye protection and protective clothing;*
- 2. If the electrolyte contacts the skin, wash it off immediately with water;*
- 3. If the electrolyte contacts the eyes, flush them thoroughly and immediately with water and seek medical attention; and*
- 4. Wash spilled electrolyte down with an acid neutralizing agent. A common practice is to use a solution of one pound (500 grams) bicarbonate of soda (also known as baking soda or sodium bicarbonate) to one gallon (4 liters) of water.*
- 5. Continue to add the bicarbonate of soda solution until the evidence of reaction (that is, foaming) has stopped.*
- 6. Flush the resulting liquid with water and dry the area.*

1.8 Moving Parts Can Cause Severe Personal Injury or Death

- Do not wear loose clothing or jewelry near moving parts, such as fans.
- Keep hands away from moving parts.
- Keep guards in place over fans.

1.9 Exhaust Gases Are Deadly

- Provide an adequate exhaust system to properly expel discharged gases away from enclosed or sheltered areas, and areas where individuals are likely to congregate. Visually and audibly inspect the exhaust system daily for leaks per the maintenance schedule. Make sure that exhaust manifolds are secured and not warped. Do not use exhaust gases to heat a compartment.
- Make sure the unit is well ventilated.

Exhaust Precautions

 **WARNING**

Hot Exhaust Gases

Contact with hot exhaust gases can cause severe burns.

Wear personal protective equipment when working on equipment.

⚠ WARNING**Hot Surfaces**

Contact with hot surfaces can cause severe burns.

Wear appropriate PPE when working on hot equipment and avoid contact with hot surfaces.

⚠ WARNING**Toxic Gases**

Inhalation of exhaust gases can cause asphyxiation and death.

Pipe exhaust gas outside and away from windows, doors, or other inlets to buildings. Do not allow exhaust gas to accumulate in habitable areas.

⚠ WARNING**Fire Hazard**

Contaminated insulation is a fire hazard. Fire can cause severe burns or death.

Remove any contaminated insulation and dispose of it in accordance with local regulations.

The exhaust outlet may be sited at the top or bottom of the generator set. Make sure that the exhaust outlet is not obstructed. Personnel using this equipment must be made aware of the exhaust position. Position the exhaust away from flammable materials - in the case of exhaust outlets at the bottom, make sure that vegetation is removed from the vicinity of the exhaust.

The exhaust pipes may have some insulating covers fitted. If these covers become contaminated they must be replaced before the generator set is run.

To minimize the risk of fire, make sure the following steps are observed:

- Make sure that the engine is allowed to cool thoroughly before performing maintenance or operation tasks.
- Clean the exhaust pipe thoroughly.

1.10 The Hazards of Carbon Monoxide

Carbon monoxide (CO) is an odorless, colorless, tasteless and non-irritating gas. You cannot see it or smell it. Red blood cells, however, have a greater affinity for CO than for oxygen. Therefore, exposure even to low levels of CO for a prolonged period can lead to asphyxiation (lack of oxygen) resulting in death. Mild effects of CO poisoning include eye irritation, dizziness, headaches, fatigue and the inability to think clearly. More extreme symptoms include vomiting, seizures and collapse.

Engine-driven generator sets produce harmful levels of carbon monoxide that can injure or kill you.

Special Risks of CO near the Home

 **WARNING**

Toxic Gases

Carbon monoxide (CO) gas can cause nausea, fainting, or death. Residents can be exposed to lethal levels of CO when the generator set is running. Depending on air temperature and wind, CO can accumulate in or near the home.

To protect yourself and others from the dangers of CO poisoning, it is recommended that reliable, approved, and operable CO detector alarms are installed in proper locations in the home as specified by their manufacturer.

Protecting Yourself from CO Poisoning

- Locate the generator set in an area where there are no windows, doors, or other access points into the home.
- Make sure all CO detectors are installed and working properly.
- Pay attention for signs of CO poisoning.
- Check the exhaust system for corrosion, obstruction, and leaks every time you start the generator set and every eight hours when you run it continuously.

This page is intentionally blank.

2 Introduction

WARNING

Hazardous Voltage

Contact with high voltages can cause severe electrical shock, burns, or death.

Make sure that only a trained and experienced electrician makes generator set electrical output connections, in accordance with the installation instructions and all applicable codes.

WARNING

Electrical Generating Equipment

Faulty electrical generating equipment can cause severe personal injury or death.

Generator sets must be installed, certified, and operated by trained and experienced person in accordance with the installation instructions and all applicable codes.

2.1 About This Manual

WARNING

Improper installation can result in severe personal injury, death and damage to equipment. The installation must comply with all applicable building codes (including project permits and inspections). The installer should be properly trained and licensed to perform electrical and mechanical equipment installations (including gaseous fuel installation).

NOTICE

Manuals are updated from time to time to reflect changes in the equipment and its specifications. The most up-to-date version of this manual is found on the QuickServe website (<https://quickserve.cummins.com/info/index.html>).

This manual is a guide for the installation of the generator set models listed on the front cover. Proper installation is essential for top performance, reliable operation, and safety. Read through this manual before starting the installation. This manual covers outdoor applications only; for other installations, refer to the T-030: Liquid-Cooled Generator Set Application Manual available from your Cummins distributor.

NOTICE

The installation must comply with all applicable building codes.

See the generator set's specific Operator Manual for operation and maintenance and specific Service Manual for service.

Refer to the Model Specifications section for specific information about the system and its components.

Refer to the Outline and System Drawings appendix and the Wiring Diagrams appendix for specific information about installation and wiring connections.

2.2 Related Literature

Before any attempt is made to operate the generator set, the operator should take time to read all of the manuals supplied with the generator set, and to familiarize themselves with the warnings and operating procedures.

The literature provided with the generator set is as follows:

- Operator Manual (A051X877)
- Installation Manual (A051X873)

NOTICE

A generator set must be operated and maintained properly if you are to expect safe and reliable operation. The Operator manual includes a maintenance schedule and a troubleshooting guide.

The Health and Safety manual must be read in conjunction with this manual for the safe operation of the generator set:

- **Health and Safety Manual (0908-0110)**
- **Warranty Statement (A028U870)**
- ***C45 N6, C50 N6 and C60 N6 models only: Emissions Component Defect Warranty Statement (A028X278)***
- ***C70 N6, C80 N6 and C100 N6 models only: Emissions Component Defect Warranty Statement (A028X279)***

The relevant manuals appropriate to your generator set are also available. The documents below are in English:

- Service Manual (A051X880)
- Parts Manual (A051X891)
- EControls, Inc., Global Control Platform (GCP) Software Service Manual (A035C596)
- EControls, Inc., 4G Software Service Manual (A052G032)
- EControls, Inc., GCP Engine Display Interface Software (EDIS) Training Manual (A035C608)
- EControls, Inc., 4G Software Operator Manual (A052G024)
- Engine Operation & Maintenance Manual for QSJ5.9G (4388606)

- RA Series Transfer Switch Owner Manual (A046S594) - if applicable
- PowerCommand® 1302 Controller Owner's Manual (900-0661)
- Service Tool Manual (A043D529)
- Standard Repair Times - HL Family (A053K365)
- T-030: Liquid Cooled Generator Set Application Manual (A040S369) - for application information

2.3 Before Installation

Before beginning the installation of the generator set, verify that the unit was correctly selected. Check the following features:

- Model
- Specifications
- Options
- Fuel Supply

2.4 Model Specifications

NOTICE

Damage caused by failure to follow the manufacturer's recommendation will not be covered by the warranty. Please contact your authorized distributor.

TABLE 1. 5.9L MODEL VARIATIONS

| Models | Description |
|---|-----------------|
| C45 N6, C50 N6, C60 N6, C70 N6, C80 N6, C100 N6 | 60 Hz, 1800 RPM |

TABLE 2. COLD WEATHER SPECIFICATIONS (ALL MODELS)

| Temperature | Description | Battery Type | Group |
|--------------------------|--|--------------|-------|
| Above 4 °C (40 °F) | Battery charger | Standard | 34 |
| -17 to 4 °C (0 to 40 °F) | Battery charger, coolant heater (1000W), CCV heater ¹ | Standard | 34 |
| Below -17 °C (0 °F) | Battery charger, coolant heater (1500W), oil heater, battery heater, CCV heater ¹ , cold weather starter ² | Larger | 4D |

| Temperature | Description | Battery Type | Group |
|---|-------------|--------------|-------|
| ¹ CCV heaters are provided as part of the cold and extreme cold coolant heater packages. | | | |
| ² The cold weather starter is provided as part of the extreme cold coolant heater package. | | | |

NOTICE

For NFPA 110 applications, a coolant heater is required. A factory option is available.

TABLE 3. FUEL SPECIFICATIONS 60 HZ, 1800 RPM

| Type | Unit | C45 N6 | C50 N6 | C60 N6 | C70 N6 | C80 N6 | C100 N6 |
|--------------------------|---|---------|---------|---------|-----------|-----------|-----------|
| Liquid Propane Full Load | scfh | 289.6 | 321.6 | 370.2 | 384.2 | 420.8 | 518.7 |
| | BTU/hr | 651,600 | 723,600 | 832,950 | 864,450 | 946,800 | 1,167,075 |
| Natural Gas Full Load | scfh | 711.2 | 806.3 | 933.8 | 988.4 | 1,083.5 | 1,317.7 |
| | BTU/hr | 721,868 | 818,395 | 947,807 | 1,003,226 | 1,099,753 | 1,337,466 |
| Fuel Pressure | 6-13 inches of water column (1.5 - 3.2 kPa) under any condition | | | | | | |

TABLE 4. ENGINE SPECIFICATIONS (ALL MODELS)

| Type | Specification |
|---|--|
| Engine | 6 cylinder-in-line, single-cam, liquid-cooled, 4-stroke, spark ignited |
| Bore | 102 mm 94.02 in) |
| Stroke | 120 mm (4.72 in) |
| Displacement | 5.88 L (359 in ³) |
| Compression Ratio (Natural Gas & LPG) | 8.5:1 |
| Firing Order | 1-5-3-6-2-4 |
| Spark Plug Gap 45, 50, 60 kW) | 0.508 mm (0.020 in) |
| Spark Plug Gap (70, 80, 100 kW) | 0.40 mm (016 in) |
| Spark Plug Torque | 38 Nm (8 ft-lb) |
| Crankshaft Rotation (Viewed from the Front of the Engine) | Clockwise |

| Type | Specification |
|--------------------------------------|---|
| Engine Weight (Dry, Long Block Only) | 413 kg (911 lb) |
| Valve Clearance (Intake) | 0.305 mm (0.012 in) |
| Valve Clearance (Exhaust) | 0.610 mm (0.024 in) |
| Coolant | <ul style="list-style-type: none"> • 50/50 coolant solution (50% pure water and 50% anti-freeze) • 16 L (4.23 gal) capacity |
| Oil Capacity | 15 L (4 gal) |
| Oil Standards | <ul style="list-style-type: none"> • Must adhere to Cummins® Engineering Standard (CES) 20085 • Use of improper oils can result in engine damage. Use only the required oils: <ul style="list-style-type: none"> ◦ 5W-40 (all ambient temperatures) ◦ 15W-40 (above 4 °C [40 °F] ambient temperature) (use of GEO 15W-40 oil in ambient temperatures below 4 °C (40 °F) could result in engine turbocharger damage) • A sulfated ash limit of 0.6% mass has been placed on all engine lubricating oils recommended for use in Cummins® B, natural gas engines. Higher ash oils can cause valve and/or piston damage, cause spark plug fouling, and lead to excessive oil consumption and degradation of the catalyst. |

TABLE 5. LUBRICATING OIL SYSTEM SPECIFICATIONS

| Type | Specification |
|---|------------------|
| Lubricating Oil Pressure at Idle (Minimum) | 104 kPa (15 psi) |
| Lubricating Oil Pressure at Rated Speed (Minimum) | |
| Filter Bypass Valve-Opening Pressure | 311 kPa (45 psi) |
| Pressure Regulator Valve-Opening Pressure | 449 kPa (65 psi) |
| Lubricating Oil Capacity (Standard Sump): | |
| --High | 14.2 L (15 qt) |
| --Low | 12.4 L (13 qt) |
| --Total System | 15.1 L (16 qt) |

TABLE 6. GENERATOR SET SIZE SPECIFICATIONS

| Enclosure Type | Size (L x W x H) |
|----------------|---|
| Open/Weather | 2489 x 1016 x 1473 mm (98 x 40 x 58 in); does not include exhaust discharge elbow |
| Sound Level 1 | 3023 x 1016 x 1473 mm (119 x 40 x 58 in) |
| Sound Level 2 | 3454 x 1016 x 1473 mm (136 x 40 x 58 in) |

TABLE 7. GENERATOR SET WET WEIGHT (POUNDS) (60 HZ, 1800 RPM)

| Configuration | C45 N6 | C50 N6 | C60 N6 | C70 N6 | C80 N6 | C100 N6 |
|---------------|--------|--------|--------|--------|--------|---------|
| Open | 2180 | 2180 | 2431 | 2449 | 2587 | 2719 |
| Weather | 2359 | 2359 | 2610 | 2628 | 2766 | 2898 |
| Sound Level 1 | 2455 | 2455 | 2706 | 2724 | 2862 | 2994 |
| Sound Level 2 | 2485 | 2485 | 2736 | 2754 | 2892 | 3024 |

NOTICE

Weights are approximate and can be affected by selected options. Refer to outline drawings for specific weight information.

TABLE 8. GENERATOR SPECIFICATIONS 60 HZ, 1800 RPM

| Type | C45 N6 | C50 N6 | C60 N6 | C70 N6 | C80 N6 | C100 N6 |
|---------------------|--|--------|--------|--------|--------|---------|
| Generator | Brushless, 4-pole rotating field, single bearing | | | | | |
| Power (kVA) 1 Phase | 45 | 50 | 60 | 70 | 80 | 100 |
| Power (kVA) 3 Phase | 56.3 | 62.5 | 75 | 87.5 | 100 | 125 |
| Rated Voltages (V) | 120/240, 1 Ph | | | | | |
| | 227/480, 3 Ph | | | | | |
| | 347/600, 3 Ph | | | | | |
| | 120/240, 3 Ph | | | | | |
| | 120/208, 3 Ph | | | | | |
| | 127/220, 3 Ph | | | | | |
| | F1PO (Reconnectable, Full Single Phase Output) | | | | | |

NOTICE

Maximum $I_2 = 8\%$. Generator set load unbalance must not exceed 25% between any phases.

TABLE 9. GENERATOR SET DERATING GUIDELINES

| Model | Phase | Engine Power Available Up To... | | Derate At... | |
|---------|-------|---------------------------------|---------------------|--------------------------|-------------------------|
| | | Elevation | Ambient Temperature | Elevation | Temperature |
| C45 N6 | Both | 675 m (2200 ft) | 40 °C (104 °F) | 4% per 300 m (985 ft) | 2% per 10 °C (18 °F) |
| C50 N6 | Both | 150 m (490 ft) | 25 °C (77 °F) | | |
| C60 N6 | Both | 1000 m (3280 ft) | 40 °C (104 °F) | | |
| C70 N6 | 1 | 2575 m (8450 ft) | | | |
| | 3 | 3048 m (10000 ft) | | | |
| C80 N6 | 1 | 1825 m (5985 ft) | | | |
| | 3 | 2500 m (8200 ft) | | | |
| C100 N6 | 1 | 700 m (1560 ft) | 25 °C (77 °F) | | |
| | 3 | 1000 m (3280 ft) | 40 °C (104 °F) | | |

TABLE 10. CONTROL SPECIFICATIONS (ALL MODELS)

| Control | Purpose |
|--------------------|--|
| PC 1.1 | Generator Set |
| Enovations I28 EPR | Engine (45, 50, 60 kW Generator Sets) |
| Enovations 4G LDI | Engine (70, 80, 100 kW Generator Sets) |

TABLE 11. DC SYSTEM SPECIFICATIONS (ALL MODELS)

| Type | Specification |
|-------------------------|--|
| Nominal Battery Voltage | 12 VDC |
| Battery Group | 34 standard, 4D high capacity (requires large battery tray) |
| Battery Type | Maintenance-free |
| Minimum Cold Crank Amps | 850 standard, 1080 high capacity (requires large battery tray) |

This page is intentionally blank.

3 Pre-Installation Considerations

Areas of consideration:

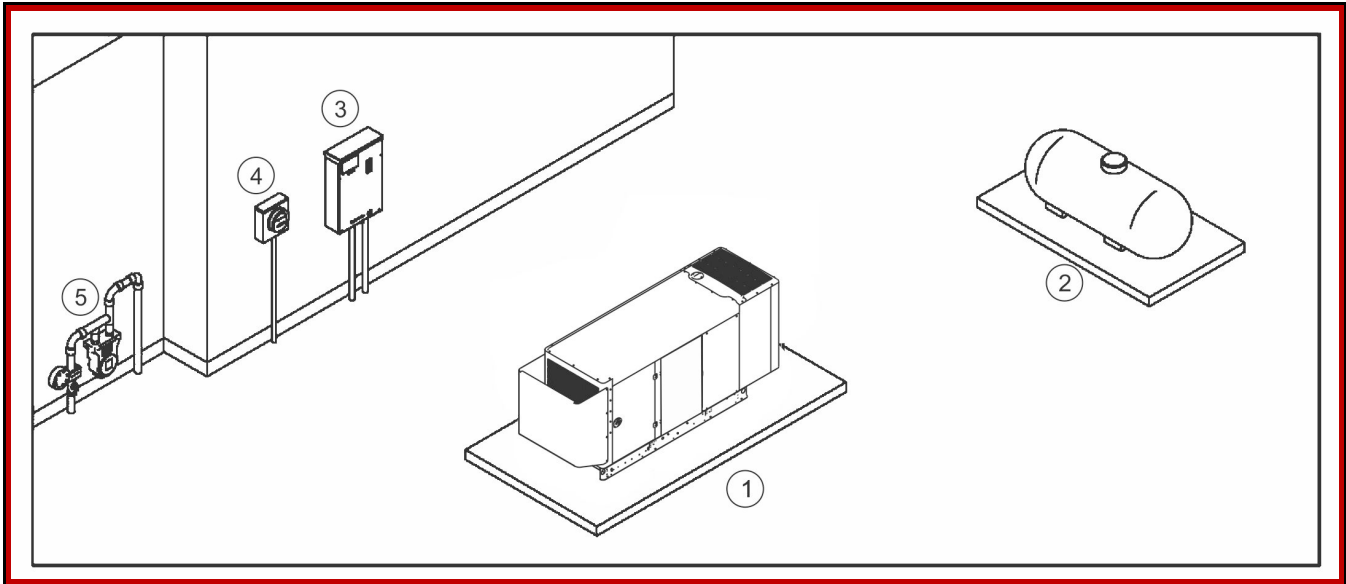

| No. | Description | No. | Description |
|-----|-----------------|-----|-------------------|
| 1 | Generator Set | 4 | Electrical Meter |
| 2 | Propane Tank | 5 | Natural Gas Meter |
| 3 | Transfer Switch | | |

FIGURE 1. SITE PREPARATION EXAMPLE

- Location of the generator set - this is one of the first decisions to be made, as it affects all other aspects of the installation, such as:
 - Length of electric wiring
 - Length of gas lines (natural gas or propane - both must be inspected by the gas utility inspectors and building inspectors)
 - Site preparation:
 - Access to the site
 - Trenches
 - Site preparation materials needed
- Fuel supply pressure
- Automatic transfer switch location and connections
- Tools and materials required

- Minimum distance from the propane tank fill (verify the legal minimum distance with local code officials)
- Accessories required (if any) for the customer's application (utility power may be required at the generator set; make plans accordingly)

NOTICE

Depending on the locality and use of the generator set, it may be necessary to obtain an air quality emissions permit before installation begins. Check with local pollution control or air quality authority to determine permit requirements.

3.2 Installation Codes and Standards for Safety

NOTICE

The generator set installer bears sole responsibility for following all applicable local codes and regulations.

The following list of codes and standards may apply to the installation and operation of the generator set. This list is for reference only and not intended to be inclusive of all applicable codes and standards. The address of each agency is listed so that copies of the codes may be obtained for reference. Installation codes and recommendations are subject to change, and may vary by location or over time.

TABLE 12. INSTALLATION CODES AND STANDARDS FOR SAFETY RECOMMENDATIONS

| Code or Standard | Organization |
|--|---|
| NFPA 70 - National Electrical Code NFPA 37 - Installation and Use of Stationary Combustion Engines and Gas Turbines NFPA 54 - National Fuel Gas Code NFPA 58 - Storage and Handling of Liquefied Petroleum Gases NFPA 110 - Standard for Emergency and Standby Power Systems | National Fire Protection Association 470 Atlantic Avenue Boston, MA 02210 |
| CSA Electrical Bulletin CSA 22.1 Canadian Electrical Code CSA B149 Installation Code for Gas Burning Appliances and Equipment CSA C22.2 No. 100 Motors and Generators CSA C22.2 No. 14 Industrial Control Equipment | Canadian Standards Association Housing and Construction Materials Section 178 Rexdale Blvd. Rexdale, Ontario, Canada M9Q 1R3 |

| Code or Standard | Organization |
|---|--|
| California Administrative Code - Title 25 Chapter 3 | State of California Documents Section P.O. Box 1015 North Highlands, CA 95660 |

3.3 Required Items for Installation

Tools and materials are used for the installation of this generator set. These items are identified in the following sections. Please refer to local codes and standards, because they may affect the materials required.

Materials Required

NOTICE

Refer to local codes and standards, which may affect material requirements.

NOTICE

If a 100% rated breaker is used, 90 °C wire must be used for L1, L2, and L3 with the wire size determined by the 75 °C ampacity tables. Aluminum wire is not allowed with 100% rated breakers.

NOTICE

A UL-listed grounding electrode terminal within its ratings and suitable for the application must be installed and labeled “Grounding Electrode Terminal”.

Electrical Materials:

NOTICE

Class 1 wiring methods must be used for connecting the generator set.

- Four code compliant AC power wires; L1, L2, N and Gnd (add another wire for 3-phase for a total of 5 AC wires)
- If an RA automatic transfer switch will be installed, refer to the RA Series Transfer Switch Owner Manual.
- Wire sizes (DC control and power and AC sense only):
 - DC control or AC sense wires under 1000 feet circuit length => 18-14 AWG of the insulation type below

- DC control or AC sense wires 1000-2000 feet circuit length => 16-14 AWG of the insulation type below
- All AC and DC wires and cables must be rated 75 °C minimum, stranded copper, and rated for wet locations.
 - For wire sizes 14 AWG and larger, use insulation types: RHW, RHW-2, THHW, THW, THW-2, THWN, THWN-2, XHHW, XHHW-2, USE-2, ZW-2
 - For wire sizes 16 and 18 AWG, use insulation types: FFH-2, KFF-2, PAFF, PFF, PGFF, PTFE, RFH-2, RFHH-2, RFHH-3, SFF-2, TFF, TFFN, ZFF
- Code compliant 20 A, 120 VAC, GFCI protected circuit for alternator heaters, battery charger, coolant heater, oil heater, and/or battery heater (if equipped)
- Code compliant conduit for all wires

Mounting Materials:

- Four base tie-down bolts

NOTICE

Seismic zone installations require compliance to specific mounting configurations.

Fuel Materials:

- Flexible fuel line (provided with the generator set, attached to the radiator guard)
- UL listed pipe thread sealant
- Fuel line at generator set (natural gas and propane: 6-13 inches of water column [1.5 - 3.2 kPa] fuel pressure)
- Fuel pressure regulator (as required)
- Manual fuel shut-off at generator set ahead of automatic valves on generator set fuel system

Loose Parts Shipped with the Generator Set

The following loose parts are shipped with the generator set:

- Flexible fuel hose assembly (attached to the radiator guard)
- One enclosure key (where applicable)
- Battery tie-down
- Sound level 2 baffle (where applicable)
- Weather enclosure exhaust elbow (where applicable)
- Literature (Operator Manual, Installation Manual, Health and Safety Manual, and Warranty Statements)

4 Installation

4.1 Site Assessment and Preparation

Proper component location and site preparation have a very important impact on completing a successful installation. The major components and sources of power needed for installation include the following items:

- Generator set
- Transfer switch
- Electrical utility
- Fuel source
- Accessories (may be required under certain conditions)

Picking a Location

⚠ WARNING

Exhaust gas is deadly. Locate the generator set away from doors, windows, and other openings to the house and where exhaust gases will disperse away from the house.

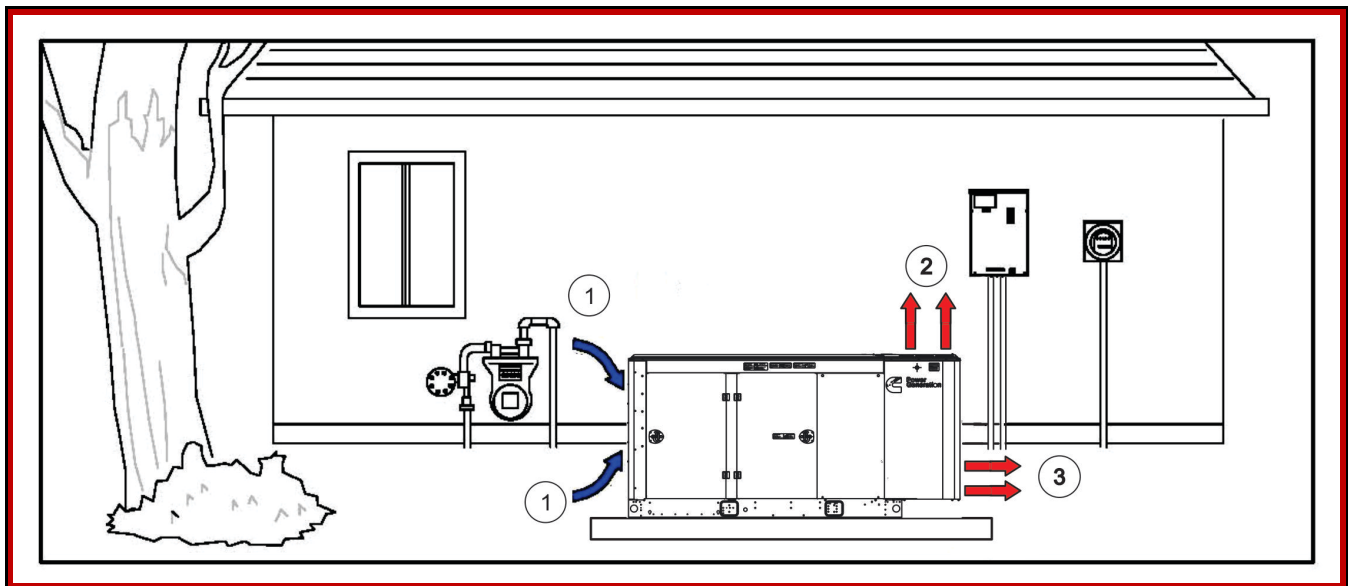

| No. | Description | No. | Description |
|-----|-------------------------------------|-----|---------------------------------|
| 1 | Cool Air In | 3 | Hot Air Out (Weather Enclosure) |
| 2 | Hot Air Out (Sound Level Enclosure) | | |

FIGURE 2. GENERATOR SET LOCATION

The generator set location is critical for safety and performance. Follow the guidelines below:

- Must comply with applicable codes (NFPA, NEC, IBC, etc.).
- This manual only covers outdoor installations with Cummins factory installed enclosures. For other installation types, contact your local Cummins dealer or reference the Application Manual at the following link: <http://www.cumminspower.com/www/literature/applicationmanuals/t030.pdf>
- Consider access to utilities (electric meters, transfer switch, remote fuel tank location, etc.).
- Call the local utilities to mark the locations of buried utility services (gas, electric, or telephone) before digging.
- Verify the locations of any other buried components (gas, electric or telephone) with the homeowner before digging.

Follow the clearance guidelines below:

- The exhaust side of the generator set must be located 5 feet from combustible materials (NFPA 37).
- The exhaust side of the generator must be located 5 feet from any opening in a wall (window, door, vent, etc.).
- The generator must be located such that the exhaust is not able to accumulate in an occupied area.
- The generator must have enough room for installation, service, and maintenance.
- The generator must be located to ensure ventilation openings are not blocked.
- Position the generator set so that cooling air is free to enter and leave the area.
- Locate and position the generator set so that prevailing winds carry exhaust gases and potential fuel leaks away from the house or occupied area.

Laying the Foundation

When laying the foundation:

1. Clear obstructions, and make sure that there is adequate clearance for access.
2. Level the ground, and make sure that the ground is compact and settled. Ensure that it is stable ground, not subject to flooding.
3. Prepare the concrete pad.
 - The pad should be constructed of reinforced concrete with a 28-day compressive strength of at least 2500 psi (17,237 kPa).
 - The pad should be at least 5 in (127 mm) deep and extend at least 6 in (150 mm) beyond the skid on all sides.

NOTICE

Refer to the foundation drawing for stub-up dimensions.

NOTICE

Seismic installation may require a different pad and securing devices.

NOTICE

Local codes and standards may have different requirements.

4. Lift the generator set onto the pad, and secure it.

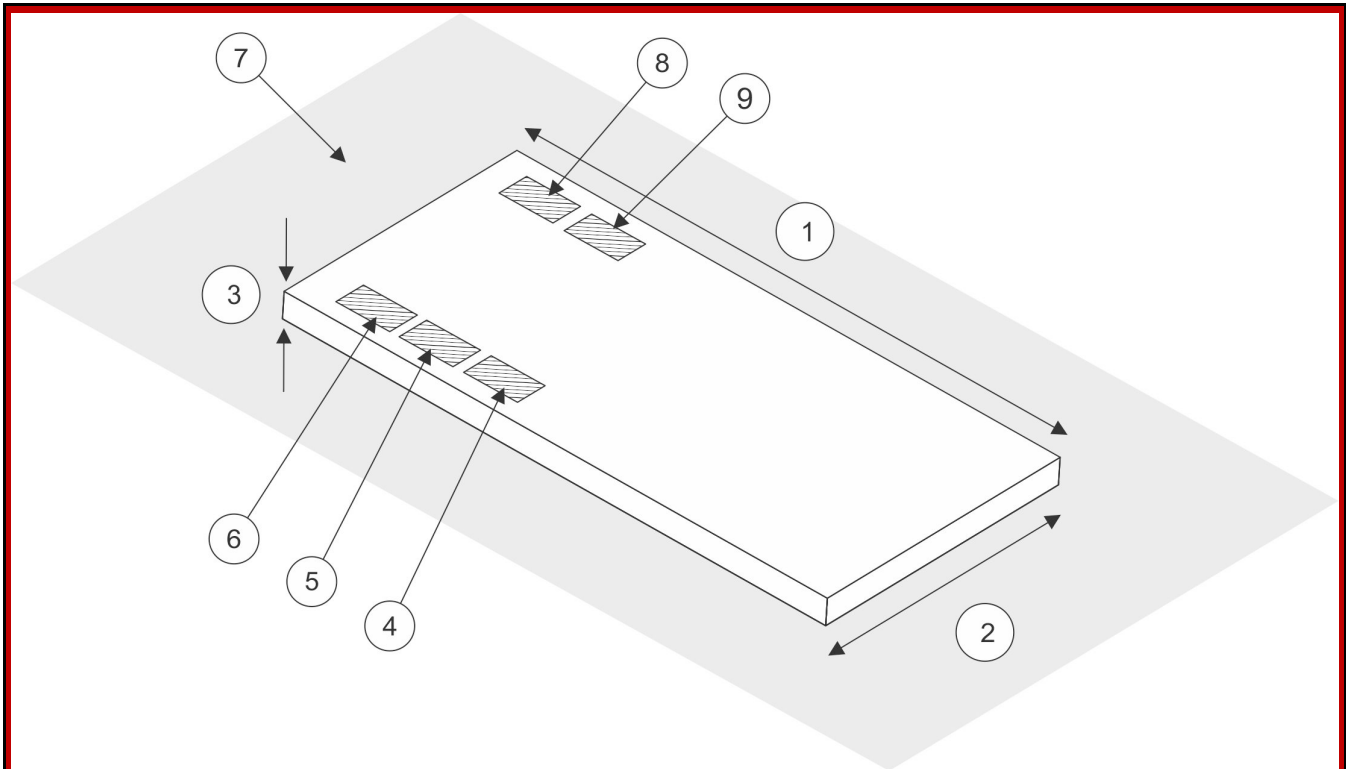

| No. | Description | No. | Description |
|-----|---|-----|---|
| 1 | Pad Length (Must Extend Minimum 6 in Beyond Skid) | 6 | Circuit Breaker 3 Stub-Up (Optional) |
| 2 | Pad Width (Must Extend Minimum 6 in Beyond Skid) | 7 | 5 ft Clearance (Shaded Area) |
| 3 | Pad Thickness (Minimum 5 in) | 8 | Accessory 120 VAC, 20A Max Wire Stub-Up |
| 4 | Circuit Breaker 1 Stub-Up | 9 | Generator Set Control Wire Stub-Up (DC) |
| 5 | Circuit Breaker 2 Stub-Up (Optional) | | |

FIGURE 3. CONCRETE PAD PREPARATION

Lifting and Moving the Generator Set

WARNING

Heavy Load

The generator set is heavy. Handle with care.

Dropping the generator set can cause severe personal injury or death. Use appropriate lifting techniques to move the generator set. Keep feet and hands clear when lifting the generator set.

CAUTION

The generator set is shipped with oil in the engine crankcase. Keep the generator set upright.

Mounting the Generator Set

Mount the generator set on a substantial and level base such as a concrete pad. A non-combustible material must be used for the pad. Verify that the mounting pad is level lengthwise, widthwise, and diagonally.

NOTICE

Seismic installation may require specific anchorage.

4.2 Fuel Selection and Fuel System Connection

For fuel specifications (such as BTU/hr), see the Model Specifications section.

NOTICE

This generator set has a convertible fuel system. The generator may run on natural gas or propane, depending on the preferences of the owner. All generator sets come preconfigured from the factory for natural gas fuel. For more information on converting the fuel system type, refer to the Service Manual.

NOTICE

Fuel systems must be installed by qualified service technicians. Improper installation presents hazards of fire and improper operation, resulting in severe personal injury or property damage.

⚠ WARNING

Gaseous fuels are flammable, explosive, and can cause severe personal injury or death. Do not smoke if you smell gas, are near fuel tanks for fuel-burning equipment, or are in an area sharing ventilation with such equipment. Keep flames, sparks, pilot lights, electrical arcs, arc-producing equipment and all other sources of ignition well away. Keep a type ABC fire extinguisher handy.

In all fuel system installations, cleanliness is extremely important.

- Make every effort to prevent fuel contamination from:
 - Moisture
 - Dirt
 - Excess thread sealant
 - Contaminants of any kind
- Clean all fuel system components before installing.

Gaseous-fuel supply system design, materials, components, fabrication, assembly, installation, testing, inspection, operation, and maintenance must comply with the applicable codes. See NFPA Standards No. 37, 54, and 58. For seismic installation, refer to the seismic label. Where seismic installation is required, there may be specific anchorage requirements for the generator set and other installed components.

Most codes require a manual shutoff valve ahead of a flexible fuel hose. The manual valve should be of the indicating type. The generator set has electric (battery-powered) shutoff valves included.

NOTICE

It is recommended that a shutoff valve be located near the generator set for emergency shut off or servicing the generator set. Follow applicable codes.

Until the generator set is connected, cap the fuel line stub-up at the generator set to prevent dirt from entering and gas from discharging if the gas supply shutoff valve is opened accidentally.

To determine the required capacity, refer to the Fuel Line Selection section.

Natural Gas Fuel System

Requirements for a natural gas generator set are as follows:

- Adequate fuel supply to operate correctly and run at full load
- Pipeline quality gas
- The length of the fuel supply pipe from the gas service entrance to the generator set must be known to determine the correct fuel pipe size (refer to the [Fuel Line Selection](#) charts)

NOTICE

Iron pipe must be a minimum of schedule 40 subject to the authority having jurisdiction.

- Cummins flexible fuel line (attached to the radiator guard) to protect the fuel system from vibration, expansion, and contraction
- Manual shutoff valve

⚠ WARNING

Fuel leaks can lead to explosive accumulations of gas. Prevent gas leaks and the accumulation of gaseous fuel in the event of a leak.

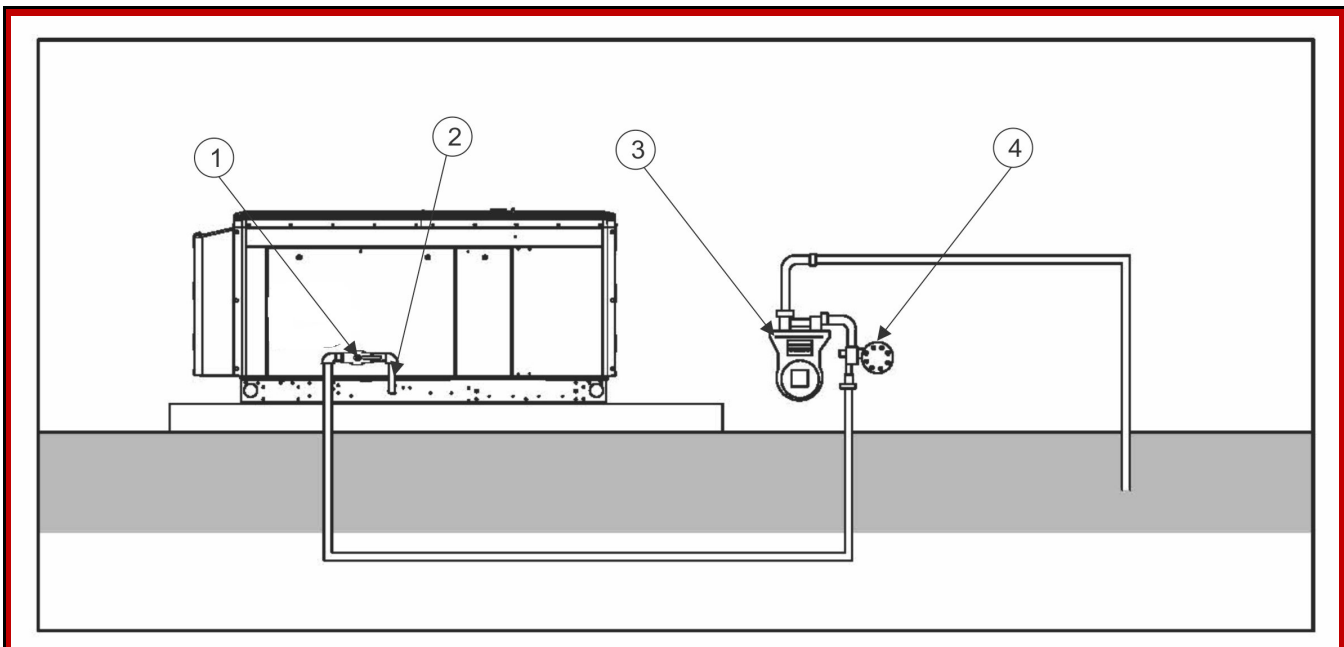

| No. | Description | No. | Description |
|-----|---|-----|-------------------|
| 1 | Shutoff Valve | 3 | Meter |
| 2 | Flexible Fuel Line (Attached to Radiator Guard) | 4 | Service Regulator |

FIGURE 4. TYPICAL NATURAL GAS INSTALLATION

Natural Gas Supply Line Size

The natural gas supply meter may need to be exchanged for a higher capacity meter to supply the additional gas consumed by the generator set.

Use the total load requirement of the generator set to determine the size of the fuel supply pipe. Use the tables and charts in the Fuel Line Selection appendix to determine the correct pipe size.

An older site might require upgrading and repair of the gas supply system. Schedule an upgrade or repair to minimize power and gas supply interruptions.

Make sure the full load fuel supply pressure at the inlet to the generator fuel shutoff valves matches the requirements in the Model Specifications section.

Propane Fuel System

Propane vapor can be used as a primary fuel source or as a backup fuel source for the generator sets with two independent fuel sources connected to the generator set.

WARNING

Fuel leaks can lead to explosive accumulations of gas. Propane sinks in air and can accumulate inside housings, basements, and other below-grade spaces. Prevent gas leaks and the accumulation of gaseous fuel in the event of a leak.

NOTICE

NFPA Standard No. 58 requires all persons handling and operating propane to be trained in proper handling and operating procedures.

The required components in a propane vapor fuel system are as follows:

| Component | Description |
|---------------------|---|
| Propane Tank | Make sure to identify and utilize the correct tank size based on fuel flow requirements and the lowest average temperature for your region. If the tank is sized incorrectly, the generator set could run out of fuel. Refer to the Minimum LPG Tank Size figure in the Fuel Line Selection appendix. |
| Shutoff Valve | Useful during installation or in the event of a leak (may be required to meet local codes). |
| Primary Regulator | Located at the tank outlet, the primary regulator reduces the tank pressure to the working pressure in the fuel supply line. Primary and secondary regulators must be properly matched for a safe and functional system. Consult with your propane supplier to ensure that the regulators are properly sized. |
| Secondary Regulator | Located near the generator set, the secondary regulator reduces the higher line pressure to a working pressure of 6-13 inches of water column (1.5 - 3.2 kPa). Higher pressure before the secondary regulator is necessary to ensure that there is enough fuel available at the secondary regulator for a fully loaded generator set. |
| Fuel Line | Connects to the fuel supply. It must be sized properly using the propane fuel line sizing charts (see the Fuel Line Selection appendix). Installation must comply with all national, state, and local codes. |

| Component | Description |
|----------------------------|--|
| Cummins Flexible Fuel Line | Attached to radiator guard. Protects the fuel system from vibration, expansion, and contraction. |

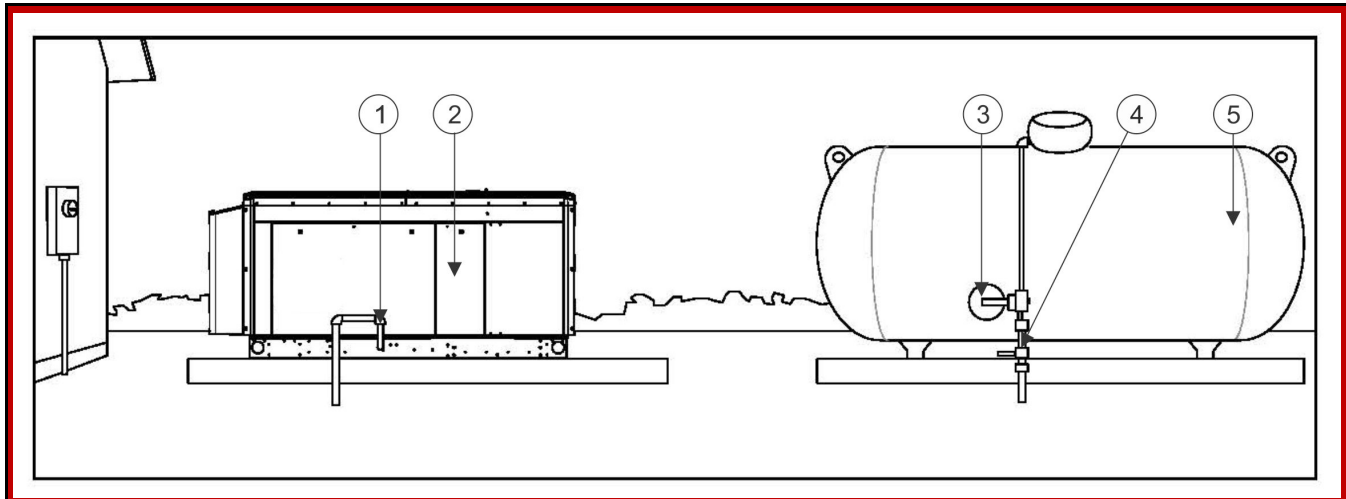

| No. | Description | No. | Description |
|-----|---|-----|---------------|
| 1 | Flexible Fuel Line (Attached to Radiator Guard) | 4 | Shutoff Valve |
| 2 | Generator Set | 5 | Propane Tank |
| 3 | Service Regulator | | |

FIGURE 5. TYPICAL PROPANE INSTALLATION

Propane Fuel Requirements

⚠ WARNING

Propane presents the hazard of fire or explosion that can cause severe personal injury or death. Do not permit any flame, spark, arc-producing equipment, switch, pilot light, cigarette, or other ignition source near the fuel system. Keep an ABC type fire extinguisher nearby.

⚠ WARNING

Fuel leaks can lead to explosive accumulations of gas. Propane sinks in air and can accumulate inside housings, basements and other below-grade spaces. Prevent gas leaks and the accumulation of gaseous fuel in the event of a leak.

Use clean, fresh HD-5 grade propane or equivalent product consisting of at least 90% propane.

NOTICE

NFPA Standard No. 58 requires all persons handling and operating propane to be trained in proper handling and operating procedures.

NOTICE

Commercial propane may contain more than 2.5% butane, which can result in poor fuel vaporization and low tank pressure, resulting in poor engine starting and operation in below 32 °F (0 °C) temperatures.

Propane Tank Size

When propane is used, size the tank correctly to ensure successful generator set operation.

Considerations when figuring the proper propane tank size:

- Temperature is a critical factor that affects the size of the tank.
 - Ambient temperatures can affect how quickly liquid is converted to gas.
 - Generator set fuel consumption is the same regardless of the surrounding temperatures.
 - Colder weather climates require larger fuel tanks. Larger tanks have greater surface area, allowing more liquid propane to vaporize and maintain the required fuel rate.
 - Propane is stored as liquid. Keep the fuel tank at least 50% full to operate properly. Fuel tanks that are less than 50% full may not have the capacity to vaporize enough propane to operate the generator set and other LP appliances.
- Propane tanks are sized by their internal volume in gallons, not the amount of fuel they can hold (which is less).
- Propane tanks are generally filled to only 80% of their capacity. Therefore, a 500-gallon (1892 L) tank results in 400-gallon (1514 L) tank capacity.
- Low ambient temperatures affect the amount of fuel available from the propane tank.
- Approximately 60% of the fuel (in gallons) filled in the tank can be effectively used. Therefore, a 500-gallon (1892 L) tank results in 240-gallon (908 L) usable capacity.

To assist in the proper installation of the propane tank, follow the guidelines below.

- Consult your tank and propane supplier for assistance in all aspects of determining tank size, selection of components and installation requirements.

- Fit the propane tanks with a pressure reducing regulator before connection to the generator set to prevent fuel system damage.
- Locate the propane tanks and all other fuel system components at least 10 feet (3 meters) from any source of combustion (including the generator set). The fuel supplier or local code may require a larger distance between the tank and source of combustion.
- Install the propane tanks according to all national and local codes and standards, and as required by the fuel tank and fuel supplier.

Refer to the [Fuel Line Selection](#) appendix for propane figures and tables.

Sizing Fuel Lines

Incorrect fuel line size may cause the generator set to not run or provide full power output. Fuel line sizes for installations typically range from 1/4 to 2 or more inches in diameter.

To determine the optimal fuel line size, the following information is needed:

| Category | Description |
|---|---|
| Fuel Flow Requirements for the Generator Set | Fuel flow requirements have a large impact on fuel line size. |
| Fuel Source (Natural Gas or Propane Vapor) | Fuel sources can affect fuel line size. Natural gas installations generally require a higher fuel flow rate compared to propane vapor installations, since propane has a higher energy content. |
| Fuel Line Length (Including Fittings) | Factor in the equivalent lengths of all of the fittings (elbows, tees, valves) in the installation in addition to the fuel line length. Longer lengths require larger diameters. |
| Fuel Line Type (e.g., Copper Tubing or Iron Pipe) | Most fuel line types are iron pipe or copper tubing. Be sure to use the sizing chart for the fuel line type when sizing the fuel line. |

There are some basic but very important steps all installers must follow to make sure that fuel lines are sized correctly:

1. Verify adequate fuel flow, quality, and pressure available from utility connection.
2. Determine fuel requirements at full load. See the Model Specifications section to determine the fuel flow requirements.
3. Determine equivalent length of fuel line fittings required. See the NFPA Pipe Fittings table in the Fuel Line Selection appendix to determine the equivalent lengths for elbows, tees, and valves. Add this length to fuel line length to determine total equivalent length.
4. Determine required fuel line size at full load. See the Fuel Line Selection appendix to determine the fuel line size.

To calculate the minimum pipe size:

1. Make a list of all the fittings and valves in a proposed system and add their equivalent lengths.
2. Add all lengths of straight pipe to arrive at a total equivalent length to the fittings/valves total.
3. Choose the applicable table based on the fuel system and fuel line material.
4. Obtain the maximum fuel requirements for the specific generator set from the Model Specifications section.
5. Refer to the fuel line sizing charts in the Fuel Line Selection appendix. Locate the equivalent length of pipe (or next larger equivalent length) in the left hand column. Move across the row to where the maximum capacity number is as large or larger than the maximum fuel consumption (or next larger). At the top of that column is the minimum nominal pipe size or tubing size required for the system as designed.

Installing Fuel Lines

The basic components required for fuel line installation are as follows:

- Flexible fuel line (attached to the radiator guard)
- Fuel line
- Shutoff valve
- Fuel supply

To install the fuel lines:

1. Connect a flexible fuel line to the fuel connection ports on the generator set.
2. Connect the opposite end of the flexible fuel line to the fuel source line near the shutoff valve.

NOTICE

A shutoff valve is recommended and often required by local and state codes.

Testing the Fuel System for Leaks

After assembly and before initial operation, all of the fuel system components must be tested and proven free of any leaks.

WARNING

Fuel presents the hazard of explosion or fire which can result in severe personal injury or death. Do not use an open flame to check for leaks. Do not smoke or allow any flame, spark, pilot light, arc-producing equipment, switch or other ignition sources around fuel or fuel components. Keep multi-class ABC fire extinguishers handy.

NOTICE

Follow any local codes and standards, as they may require a different method or documentation of a leak test.

Perform the following fuel piping system leak check:

1. After assembly and before initial operation of generator set, test all fuel system components as required per the National Fuel Gas Code (NFPA 54).
2. The National Fuel Gas Code requires that the generator set be isolated from the *piping* system by disconnecting it and capping the outlet prior to test. The test pressure required is the greater of 1.5 times the supply pressure or 3 psi (20.7 kPa) minimum.
3. After successfully completing the previous step, connect the generator set to the fuel piping system.
4. To verify that all connections from the fuel piping system to the generator set are free of leaks, conduct a bubble test using an approved leak detection solution (or equivalent method) with the system pressure of 0.8 to 1.0 psi (5.5 to 7.0 kPa).
5. Spray the bubble solution on all of the joints.
6. Inspect all of the joints and monitor the line pressure. If bubbles appear, there is a leak.
7. If any leaks are found, repair the joint or replace components as needed.
8. Verify the leak has been fixed.

NOTICE

The leak detection solution (that is, bubble solution) must be non-corrosive and be free of ammonia and chlorine.

4.3 Engine Exhaust

The exhaust system for this generator set is complete and was designed specifically for this generator set. Do not modify or add to the exhaust system of this generator set.

⚠ WARNING

Exhaust gas is deadly. Make sure that the exhaust system terminates away from building vents, windows, doors, and sheltered spaces that may not have ample fresh air ventilation.

⚠ WARNING

Engine discharge air and exhaust carry carbon monoxide gas (odorless and invisible) which can cause asphyxiation and death. Never use engine discharge air or exhaust for heating a room or enclosed space.

4.4 Electrical Connections

WARNING

Improper installation can lead to electrocution and damage to property. Electrical connections must be made by a licensed electrician.

WARNING

Automatic startup of the generator set during installation can cause severe personal injury or death. Make sure the generator set is shut down and disabled:

- 1. Press the generator set's "O" (Off) button to stop the generator set. Allow the generator set to thoroughly cool to the touch.*
- 2. Turn off and disconnect the battery charger from the AC source before disconnecting the battery cables.*
- 3. Disconnect the negative (-) cable from the battery and secure it from contacting the battery terminals to prevent accidental starting.*

NOTICE

Refer to regional codes and the National Electrical Code (NFPA 70) for all electrical installation requirements.

NOTICE

Class 1 wiring methods must be used for connecting the generator set.

AC Connections

WARNING

Automated Machinery

Accidental or remote starting of the generator set can cause severe personal injury or death.

Isolate all auxiliary supplies and use an insulated wrench to disconnect the starting battery cables, negative (-) cable first.

NOTICE

If a 100% rated breaker is used, 90 °C wire must be used for L1, L2, and L3 with the wire size determined by the 75 °C ampacity tables.

NOTICE

When using a circuit breaker with an adjustable, electronic trip unit, the amperage and trip curve settings may need adjustment to match the generator set load wiring, or downstream loads and circuit breakers. An accessory seal kit (part number A026M166) is available to tamper-proof the adjustable settings.

1. Make sure the generator set is shut down and disabled:
 - a. Press the Off switch from the display and then press the E-Stop button to stop the generator set. Allow the generator set to thoroughly cool to the touch.
 - b. Turn off and disconnect the battery charger from the AC source before disconnecting the battery cables.
 - c. Disconnect the negative (–) cable from the battery and secure it from contacting the battery terminals to prevent accidental starting.
2. Remove the enclosure side panel to gain access to the main circuit box.
3. Place the circuit breaker handle in the OFF position.
4. Remove the four bolts holding the circuit breaker cover.
5. Connect the conductors to the circuit breaker load-side terminals, neutral lug, and equipment grounding lug. For grounding and neutral connections, look for the symbols on the generator set circuit breaker box (shown below, and in the next image at the bottom).

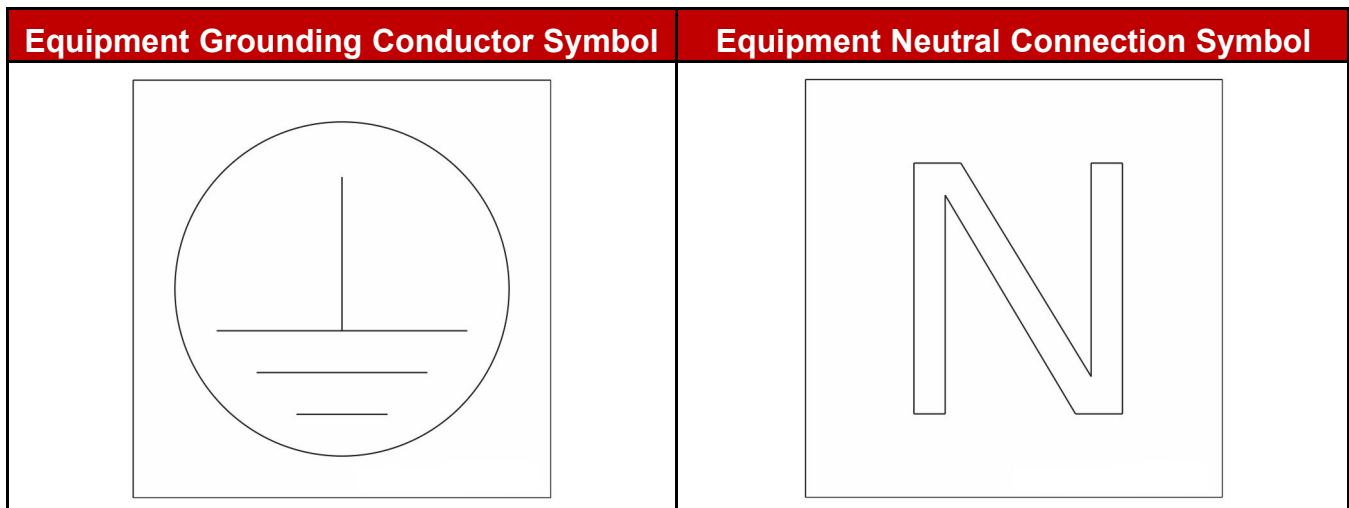

FIGURE 6. SYMBOLS ON CIRCUIT BREAKER BOX

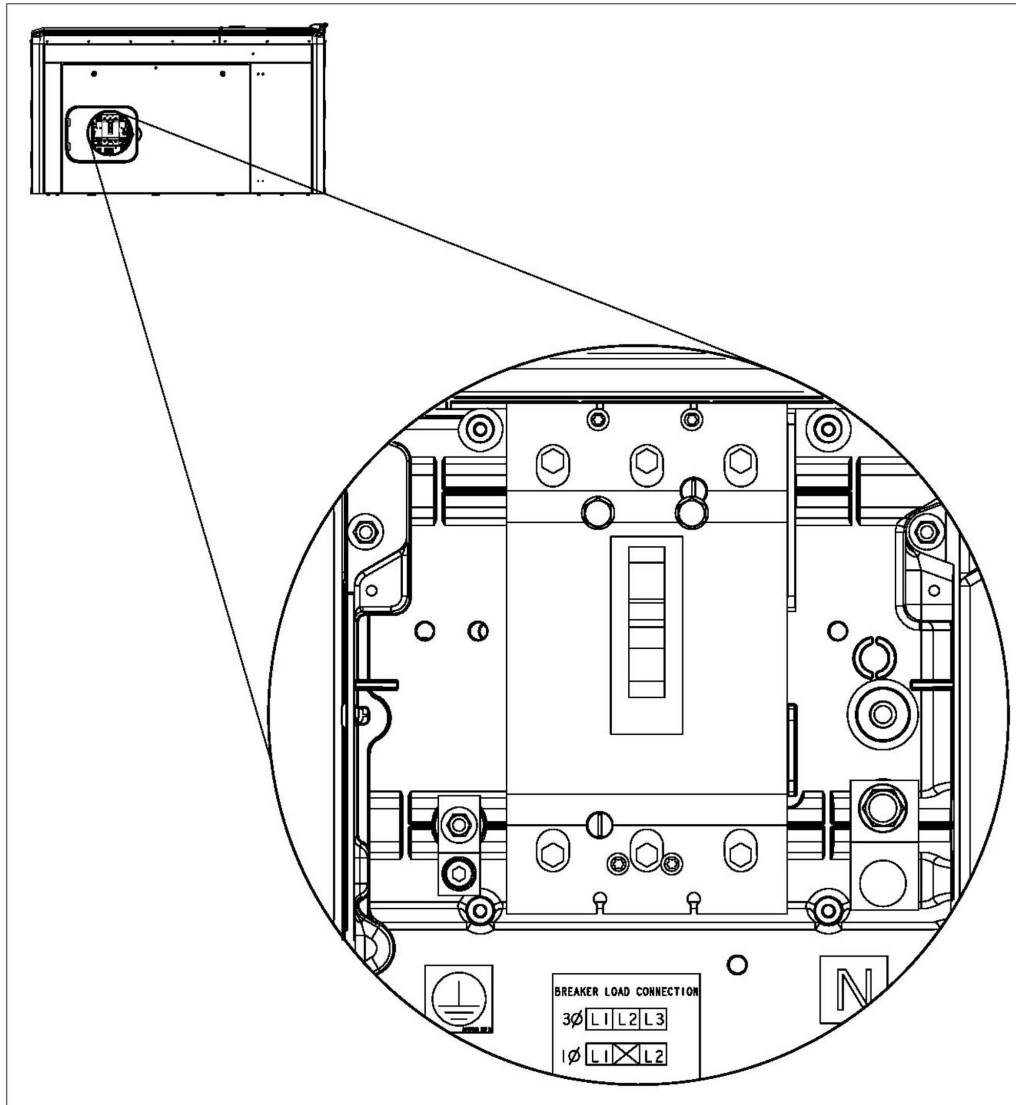

FIGURE 7. CIRCUIT BREAKER AC LOAD CONNECTIONS LOCATION (SYMBOLS SHOWN AT BOTTOM)

6. Torque the circuit breaker terminals per specifications on the circuit breaker label.
7. Torque the neutral lug to 31.1 Nm (275 in-lb).
8. Torque the equipment grounding lug to 13.8 Nm (120 in-lb).
9. Fill in the stub-up openings with an approved duct seal or mastic tape to keep out insects and rodents.
10. Install the circuit breaker cover.

Automatic Transfer Switch AC Connections

 **WARNING**

Failure to use an approved transfer switch can lead to the electrocution of personnel working on the utility lines, damage to equipment, fire, or personal injury. An approved switching device must be used to prevent interconnection to the public utility.

Install the transfer switch in accordance with the RA Series Transfer Switch Owner Manual.

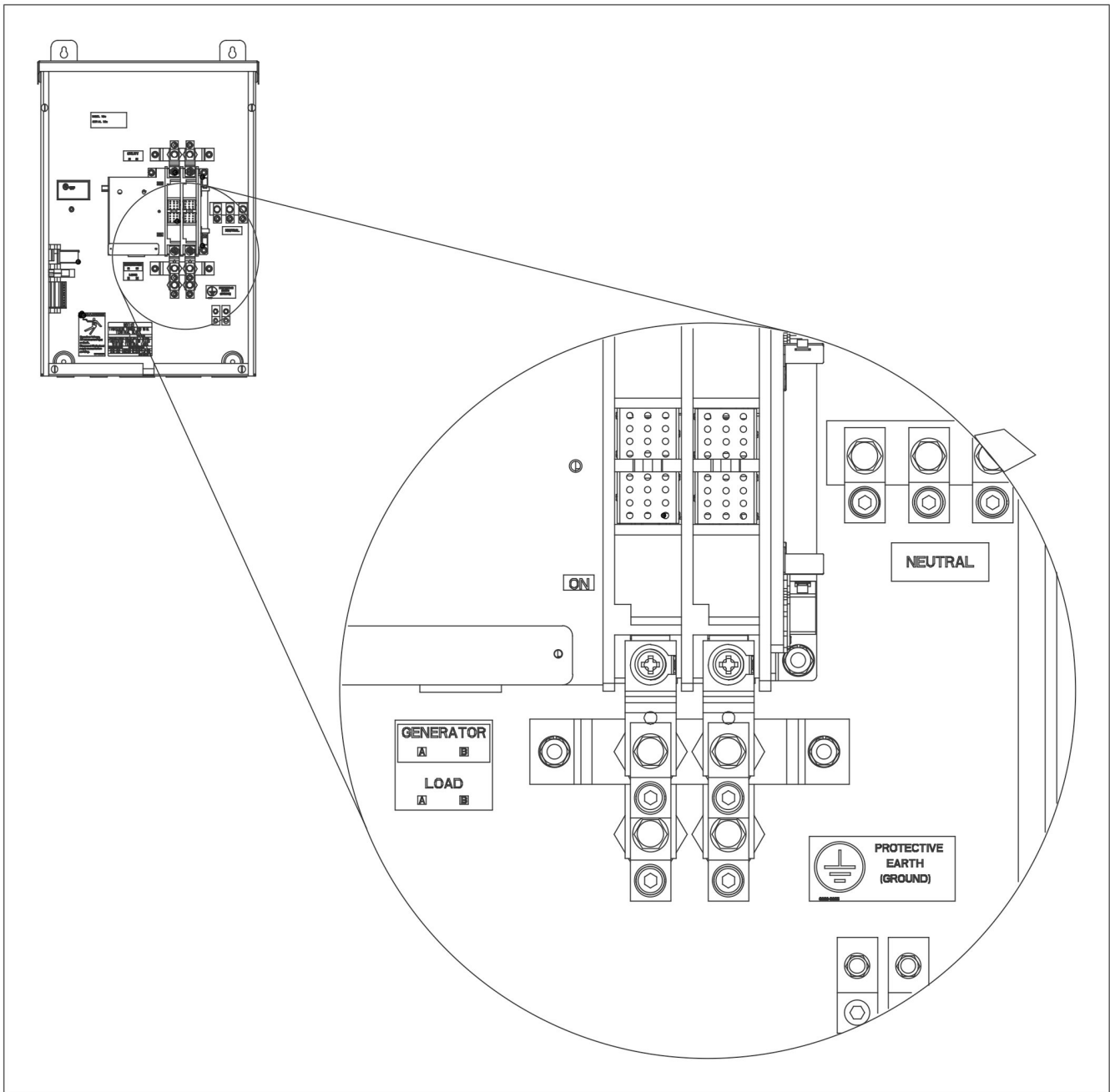

FIGURE 8. RA SERIES TRANSFER SWITCH AC CONNECTIONS LOCATION

Factory Option and Accessory Connections

The AC-powered options or accessories available include the battery charger, engine coolant heater, alternator heater, oil heater, battery warmer, and CCV heater (included with coolant heater).

NOTICE

The CCV heater requires power from a 120 VAC, 20 Amp protected circuit from the Main Distribution Panel. The CCV needs to be powered even during utility outages. Use 12 AWG 167 °F (75 °C) conductors to connect to the generator set AC distribution connector.

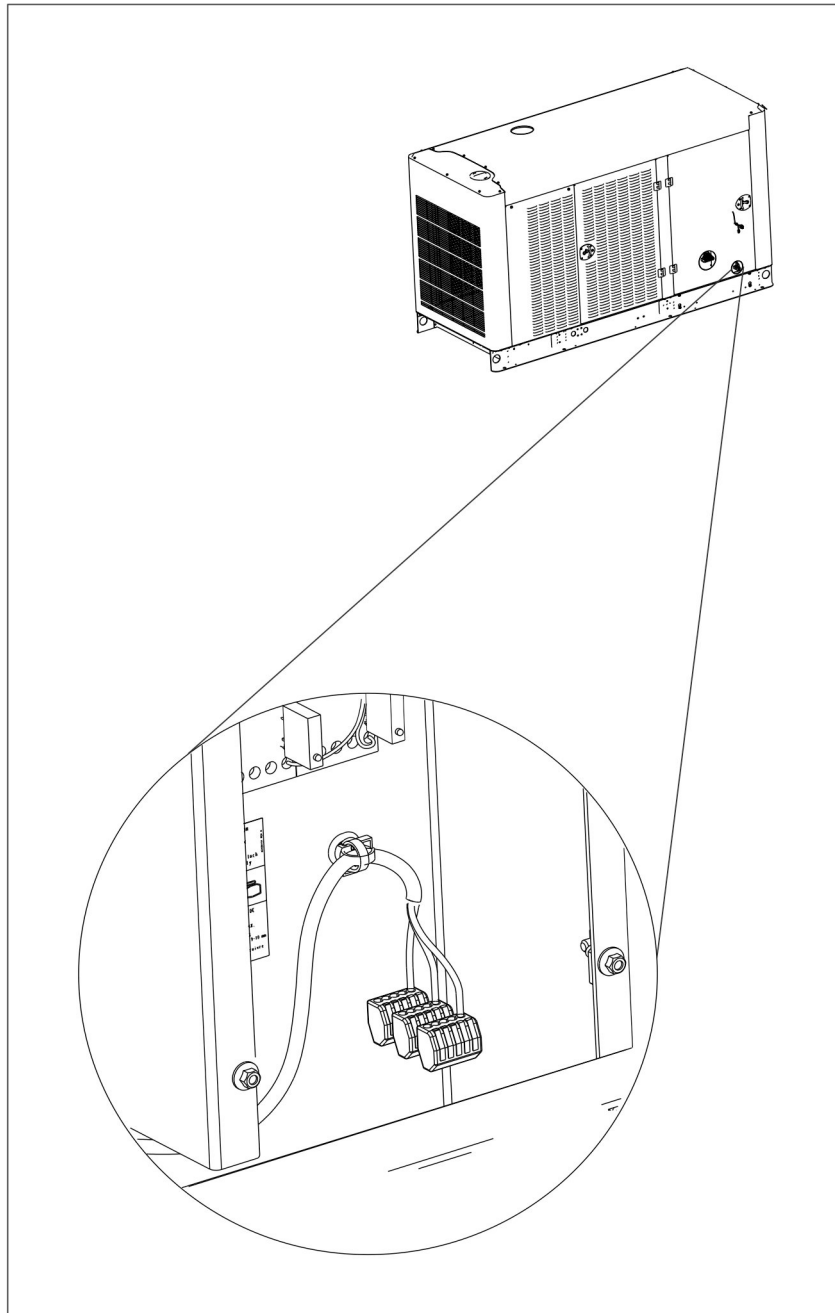
**FIGURE 9. AC ACCESSORY CONNECTIONS**

DC Connections

NOTICE

When selecting and installing conduit to the generator set, account for any needed accessories, such as a remote display, etc.

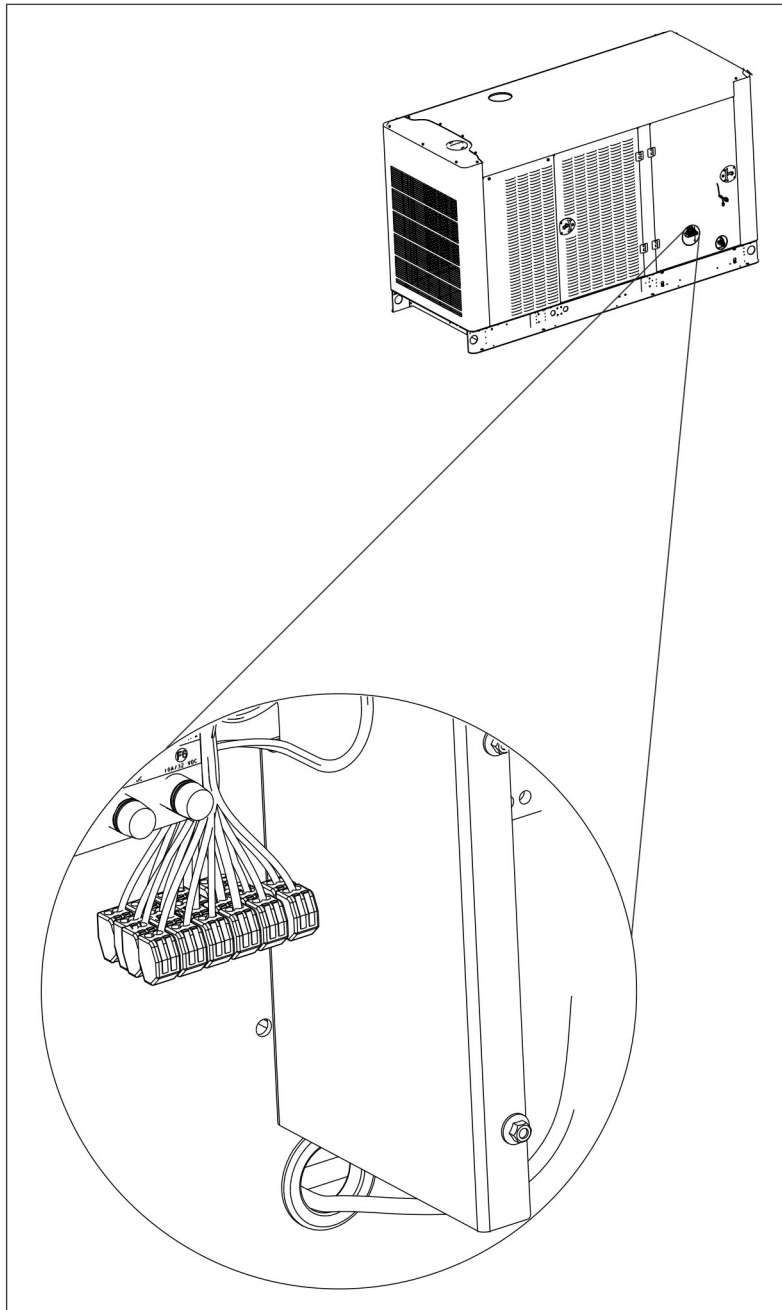

FIGURE 10. DC CUSTOMER CONNECTIONS

Automatic Transfer Switch DC Connections

⚠ WARNING

Failure to use an approved transfer switch can lead to the electrocution of personnel working on the utility lines, damage to equipment, fire, or personal injury. An approved switching device must be used to prevent interconnection to the public utility.

Install the transfer switch in accordance with the RA Series Transfer Switch Owner Manual. The following image shows the location of the Cummins RA Series Transfer Switch customer connections.

NOTICE

Class 1 wiring methods should be used for connecting the generator set and transfer switch signal wiring.

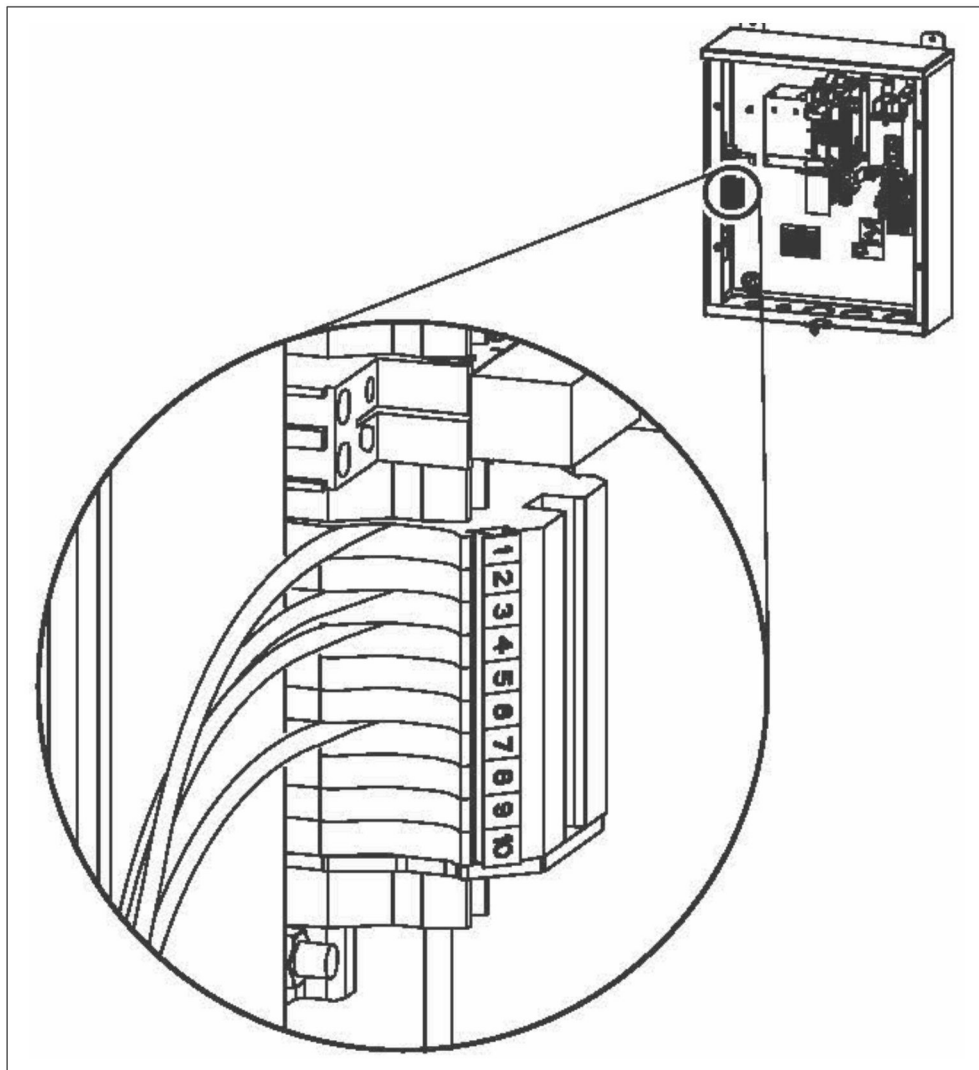

FIGURE 11. RA SERIES TRANSFER SWITCH DC CONNECTIONS LOCATION

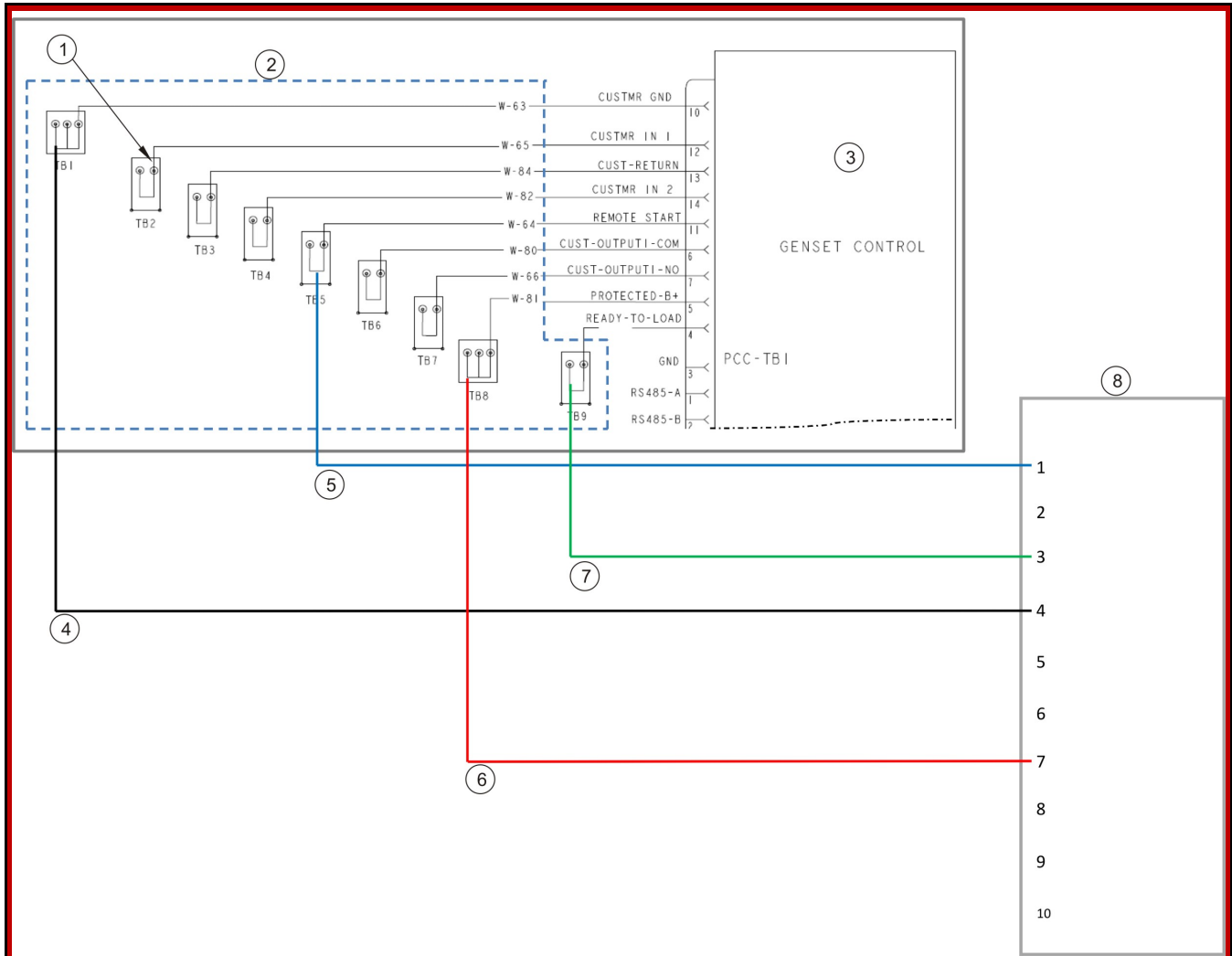

FIGURE 12. GENERATOR SET TO RA TRANSFER SWITCH DC CUSTOMER CONNECTIONS

Grounding

NOTICE

The generator set is shipped from the factory with the neutral and equipment ground not bonded together.

Refer to local codes and standards for grounding procedures.

Battery

The generator set requires a 12V battery (negatively grounded) for engine cranking and powering the electronic control system. When the generator set is running, the battery is charged from the engine-driven battery alternator. When the set is not running, an AC powered battery charger is needed to keep the battery charged.

As part of the installation, make sure that the battery is secured to the battery tray with the strap provided.

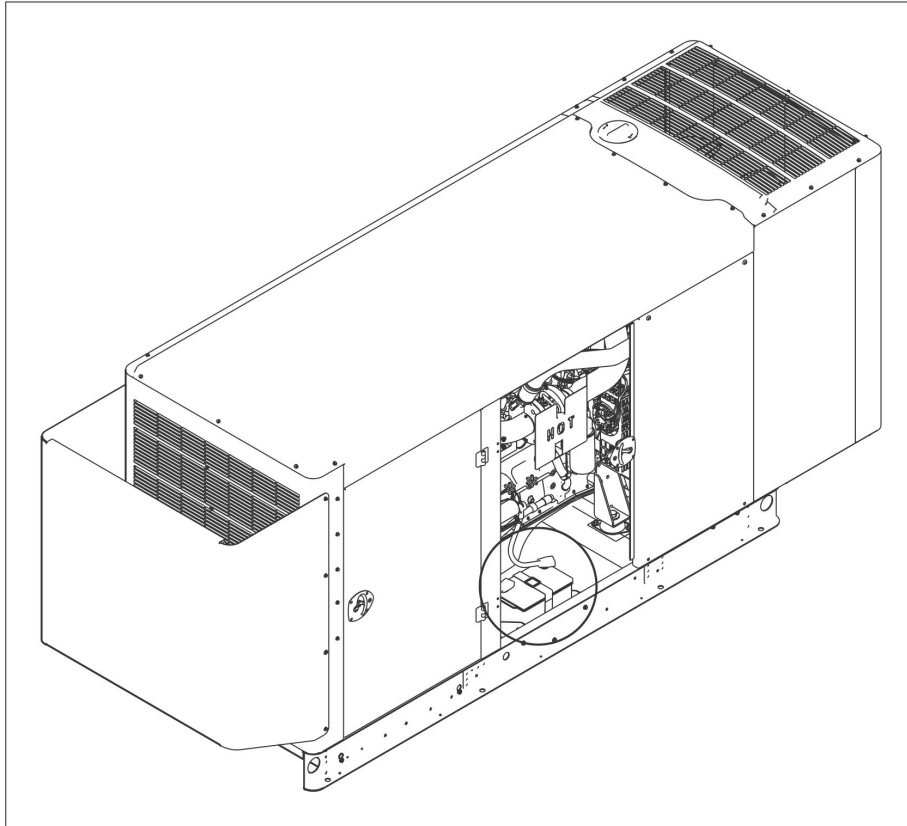

FIGURE 13. BATTERY LOCATION

⚠ CAUTION

Ensure that the AC power to the battery charger is disconnected when installing the battery.

⚠ CAUTION

Wear proper safety protection when working around batteries. Keep open flames and sparks away from the equipment.

⚠ CAUTION

Only personnel knowledgeable of batteries and required precautions should perform or supervise battery servicing.

To connect the battery:

1. Connect the positive battery terminal.
2. Connect the negative battery terminal.
3. Make sure that the black and red battery cable boots are in place.

Refer to the Model Specifications section for battery specifications.

An optional thermostatically controlled battery heater is available for more reliable starting in ambient temperatures below 0 °F (-18 °C).

To prevent injury due to accidental startup, do not connect the battery cables to the battery until the installation has been completed; tools, rags, and body parts are away from any rotating parts or electrically live parts; and it is time to start the set.

5 Startup and Configuration

5.1 Time Setup

NOTICE

When battery power is lost, these settings must be reset.

NOTICE

Not applicable without a single phase RA series transfer switch.

To set up the generator set clock for the current date and time:

1. From any Information Menu, hold down the up and down arrows simultaneously for two seconds. The Service Menu appears.
2. Access the Time Setup screen by selecting **Clock Exerciser** on the Genset Service Menu.
3. Select **Adjust**.

When updating these settings, the functions of the keys are as follows:

- The horizontal right arrow key is used to select successive blocks for editing settings on the screen.
- Select the left arrow to return to the previous screen.
- Adjust values by using the + or - keys on the Adjust Menu of the Time Setup screen.
- Press **Save** to save any changes. After saving, the Save button changes to the Adjust button.

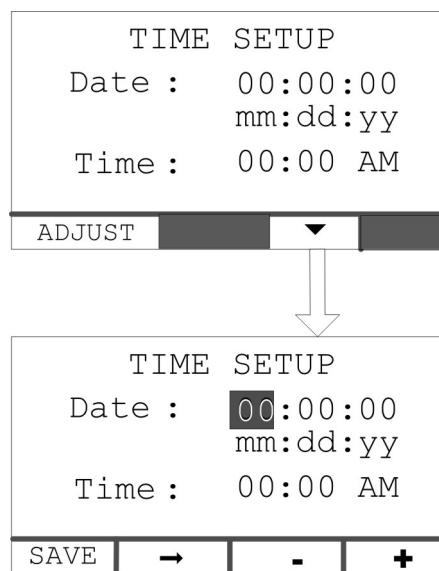

FIGURE 14. TIME SETUP SCREEN

Updating Daylight Saving Adjust Screen

To update the Time and Adjustment on the Daylight Saving Adjust screen:

1. From any Information Menu, hold down the up and down arrows simultaneously for two seconds. The Service Menu appears.
2. Access the Time Setup screen by selecting **Clock Exerciser** on the Genset Service Menu.
3. Press the down key on the Time Setup screen to access the Daylight Saving Adjust screen.
4. Select **Adjust**.

When updating these settings, the functions of the keys are as follows:

- The horizontal right arrow key is used to select successive blocks for editing settings on the screen.
- Select the left arrow to return to the previous screen.
- Adjust values by using the + or - keys on the Adjust screen of the Daylight Saving Adjust screen.
- Press **Save** to save any changes. After saving, the Save button changes to the Adjust button.

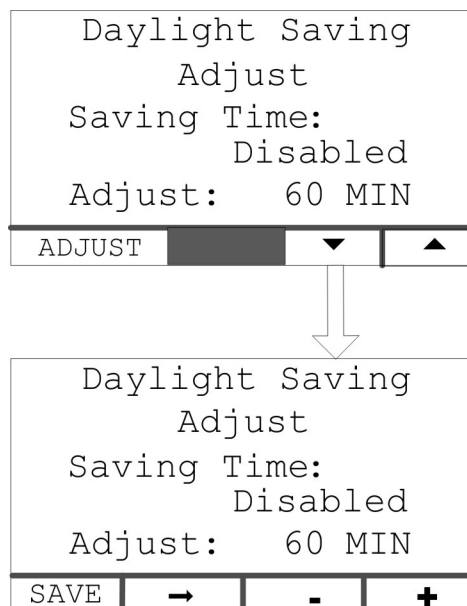

FIGURE 15. DAYLIGHT SAVING ADJUST SCREEN NAVIGATION

To access and update the Daylight Saving Adjust Start screen:

1. Press the down key on the Daylight Saving Adjust screen.
2. Press **Adjust**.

When updating these settings, the functions of the keys are as follows:

- The horizontal right arrow key is used to select successive blocks for editing settings on the screen.

- Use the + or - keys to edit the following settings:
 - Month
 - Week
 - Day
 - Hour
- Press **Save** to save any changes. After saving, the Save button changes to the Adjust button.

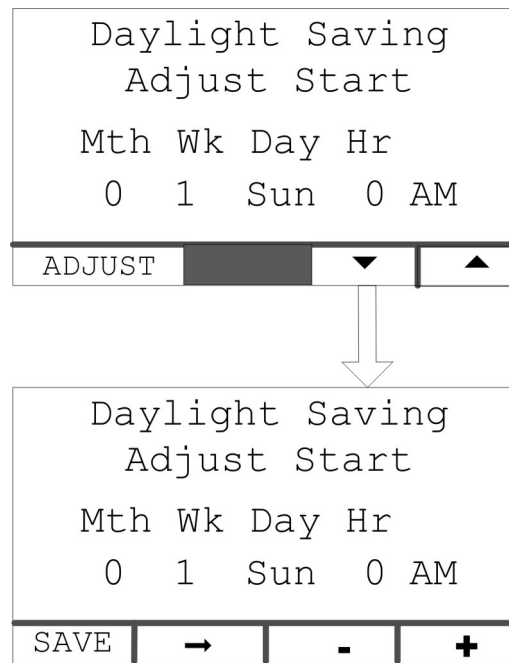

FIGURE 16. DAYLIGHT SAVING ADJUST START SCREEN

To access and update the Daylight Saving Adjust End screen:

1. Press the down key on the Daylight Saving Adjust Start screen.
2. Press **Adjust**.

When updating these settings, the functions of the keys are as follows:

- The horizontal right arrow key is used to select successive blocks for editing settings on the screen.
- Use the + or - keys to edit the following settings:
 - Month
 - Week
 - Day
 - Hour
- Press **Save** to save any changes. After saving, the Save button changes to the Adjust button.

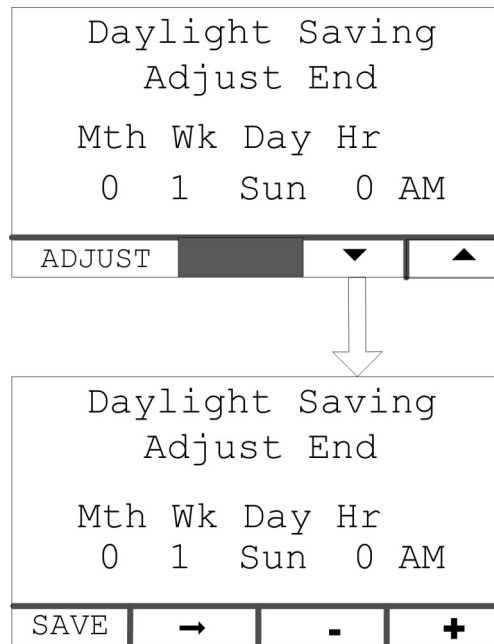

FIGURE 17. DAYLIGHT SAVING ADJUST END SCREEN

5.2 Exercise Settings

NOTICE

When battery power is lost, these settings must be reset.

NOTICE

Not applicable without a single phase RA series transfer switch.

To access the Clock/Exerciser Menu:

1. From any Information Menu, hold down the up and down arrows simultaneously for two seconds. The Service Menu appears.
2. Navigate through the screens to find and select **Clock/Excr** in the Service Menu.

NOTICE

The following screens represent the standard operator panel (that is, HMI211). If using an in-home operator panel, which may be additionally purchased as an option, the screens may look slightly different. This procedure applies to both operator panels.

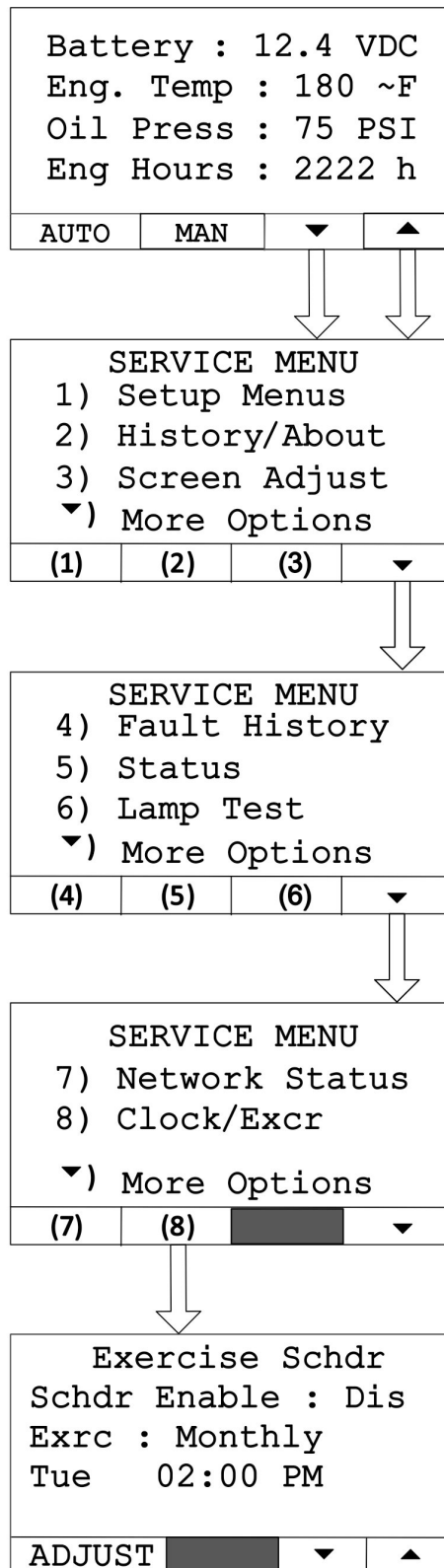

FIGURE 18. CLOCK/EXERCISER MENU NAVIGATION

Updating Exercise Frequency

NOTICE**Not applicable without a single phase RA series transfer switch.**

To update the exercise frequency and dates on the Clock/Exerciser Menu:

1. From any Information Menu, hold down the up and down arrows simultaneously for two seconds. The Service Menu appears.
2. Access the Time Setup screen by selecting **Clock Exerciser** on the Genset Service Menu.
3. Press the down key on the Time Setup screen to access the Daylight Saving Adjust screen.
4. Select **Adjust**.
5. Press the down key on the Daylight Saving Adjust Start screen.
6. Select **Adjust**.
7. Press **Exercise Schdr** on the Daylight Saving Adjust End screen.
8. Press **Adjust**.

When updating these settings, the functions of the keys are as follows:

- The horizontal right arrow key is used to select successive blocks for editing settings on the screen.
- Use the + or - keys to edit the following settings:
 - Schdr Enable: Enable or Disable
 - Exercise Schedule: Semi-Annual (every six months), Quarterly, Monthly, Bi-Monthly (the first and third week of every month based on the time set when the Bi-Monthly option is selected), or Weekly
 - Exercise Schedule: Day, Hours, Minutes, AM/PM
- Press **Save** to save any changes. After saving, the Save button changes to the Adjust button.

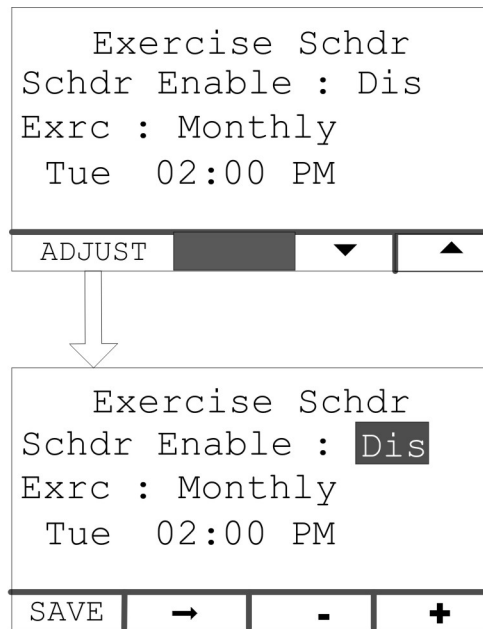

FIGURE 19. EXERCISE FREQUENCY NAVIGATION

Updating Exercise Duration

NOTICE

Not applicable without a single phase RA series transfer switch.

To update the exercise duration on the Clock/Exerciser Menu:

1. From any Information Menu, hold down the up and down arrows simultaneously for two seconds. The Service Menu appears.
2. Access the Time Setup screen by selecting **Clock Exerciser** on the Genset Service Menu.
3. Press the down key on the Time Setup screen to access the Daylight Saving Adjust screen.
4. Select **Adjust**.
5. Press the down key on the Daylight Saving Adjust Start screen.
6. Select **Adjust**.
7. Press **Exercise Schdr** on the Daylight Saving Adjust End screen.
8. Press the down key on the Exercise Schdr Menu.
9. Press **Adjust**.

When updating these settings, the functions of the keys are as follows:

- The horizontal right arrow key is used to select the duration block for editing exercise duration.
- Use the + or - keys to edit the exercise duration minutes.

- Press **Save** to save any changes. After saving, the Save button changes to the Adjust button.

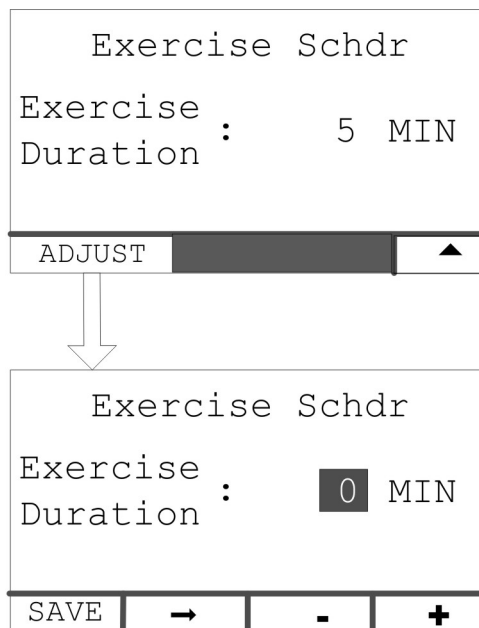

FIGURE 20. EXERCISE DURATION NAVIGATION

5.3 Brightness and Contrast

The Screen Adjust screen allows the contrast, brightness, and units to be set. To access the Screen Adjust screen:

1. From any Information screen, hold down the up and down arrows simultaneously for two seconds to gain access to the Service Menu screen.
2. Select **Screen Adjust**.

To adjust the contrast, brightness, or units from the Screen Adjust screen:

1. From the Screen Adjust screen, select **Adjust** to access the screen variables.
2. Press the right arrow to move between the variables.
3. Adjust settings, and press **Save** to save any changes.

When updating these settings, the functions of the keys are as follows:

- The horizontal right arrow key is used to select successive blocks for editing settings on the screen.
- Select the left arrow to return to the previous screen.
- Adjust values by using the + or - keys on the Adjust screen of the Display Setup screen.
- Press **Save** to save any changes. After saving, the Save button changes to the Adjust button.

NOTICE

The following screens represent the standard operator panel (HMI211). If using an in-home operator panel, which may be additionally purchased as an option, the screens may look slightly different. This procedure applies to both operator panels.

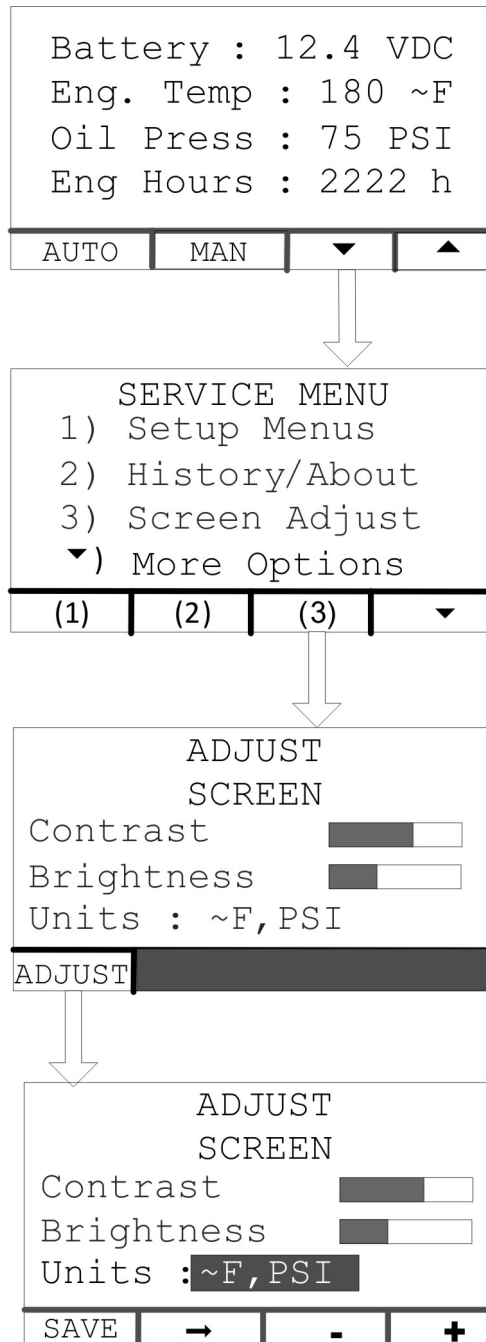

FIGURE 21. BRIGHTNESS AND CONTRAST SCREEN NAVIGATION

NOTICE

Adjusting the brightness on the operator panel adjusts the brightness of both the LCD backlight and the LEDs on the display. The contrast should never be 0 or 100% on any of the screens. The default value for Brightness is 50%.

5.4 History and About Menu

To access the History/About screen:

1. From any Information Menu, hold down the up and down arrows simultaneously for two seconds. The Service Menu appears.
2. Select **History/About**.
3. Advance through the screens to view information about the generator set, control, and display.

NOTICE

The following screens represent the standard operator panel (HMI211). If using an in-home operator panel, which may be additionally purchased as an option, the screens may look slightly different. This procedure applies to both operator panels.

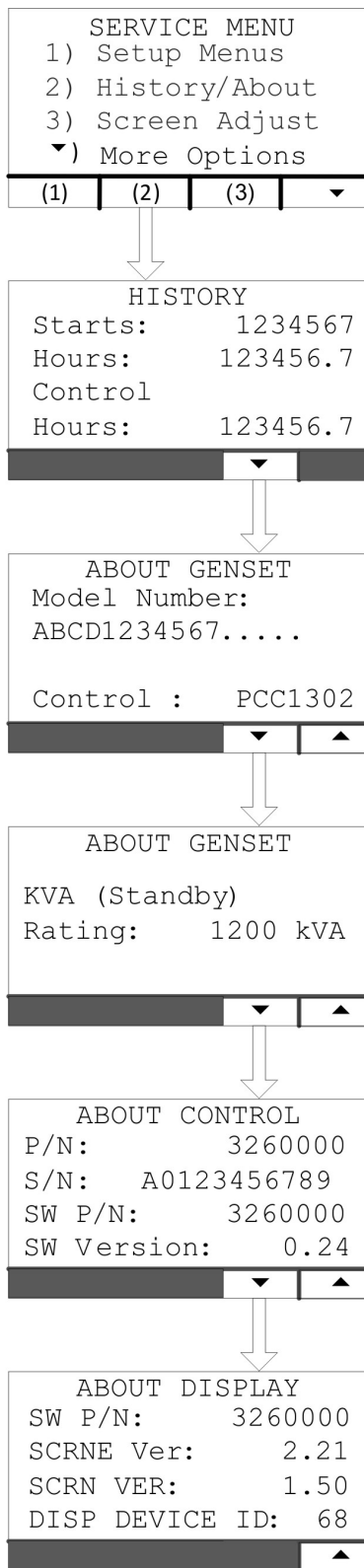

FIGURE 22. HISTORY/ABOUT MENU

5.5 Checklist

| Tick | Item |
|------|--|
| | General |
| | Generator set wattage capacity is sufficient to handle maximum anticipated load. |
| | At least 5 feet of clearance to combustible materials is provided. At least 3 feet of clearance is provided around the entire generator set for service and ventilation. |
| | The generator set is located in an area not subject to flooding. |
| | All installers have read and are familiar with the Generator Set Installation manual and the Health and Safety manual. |
| | All installers have been thoroughly briefed on preventive maintenance procedures. |
| | All installers have read and understand all important safety instructions. |
| | Generator Set Support |
| | The floor, roof or earth on which the generator set rests is strong enough and will not allow shifting or movement. Local codes for soil bearing capacity were followed. |
| | The generator set is properly supported and secured to an approved base. |
| | The supporting base is of non-combustible material and extends 6 inches all around the generator set. |
| | Fuel System |
| | The generator set is configured to the fuel being used. (See the Fuel Selection and Fuel System Connection section.) |
| | Fuel line size has been verified for generator set fuel consumption and pressure. |
| | An approved flexible fuel line (attached to the radiator guard) is installed between the main fuel supply and the generator set's fuel system near the generator set |
| | Fuel lines are properly installed, supported and protected against damage. |
| | Fuel supply shutoff valves are installed to turn off fuel flow in case of leaks. |
| | No leaks are found in fuel supply line as a result of leak testing fuel systems. |
| | The inside of all fuel supply lines is free of contaminants. |
| | The fuel pressure is at 1.5 - 3.2 kPa (6-13 inches of water column) under any condition. |
| | Fuel pressure maintains at least 1.5 kPa (6 inches water column) when the generator set is at rated load. |
| | The installation is compliant with all state and local codes and regulations. |
| | AC and DC Wiring |
| | The control is configured for the proper fuel type. |

| Tick | Item |
|------|--|
| | Wire sizes, wire types, insulation, conduits and connection methods all meet applicable codes. |
| | AC and DC wires are separated in their own conduit to prevent electrical induction. |
| | All load, line and generator connections are well made and correct. |
| | Generator Set Pre-Start |
| | A safety check was performed just before starting. |
| | The generator set engine is properly serviced with oil and coolant. |
| | The battery is properly installed, serviced and charged. |
| | The battery charger and engine coolant heater are connected and operational, if applicable. |
| | All generator set covers and safety shields are installed correctly. |
| | The fuel supply is turned on. |
| | All fuel shutoff valves are operational. |
| | The date and time have been set in the generator set control. |
| | The generator set operating mode has been selected. |

5.6 Startup

WARNING

Automated Machinery

Accidental or remote starting of the generator set can cause severe personal injury or death.

Isolate all auxiliary supplies and use an insulated wrench to disconnect the starting battery cables, negative (-) cable first.

After verifying that the installation was completed correctly, start and test the system. Make sure to connect the battery cables to the battery with the positive (+) cable first.

Read through the Operator Manual and perform the maintenance and pre-start checks as instructed.

The following information applies to C70 N6, C80 N6, and C100 N6 generator set models only: Adaptive learn is an engine ECM function that allows the generator set to "learn" its environment. There are small differences in the performance of each engine and fuel system component, so the ECM uses inputs from the engine sensors to adjust running conditions to operate more consistently for each individual generator set. After installation is complete and while testing the overall system function, the generator set must be run with no active faults under load (that is, transfer switch connected to maximum customer load available) until the engine temperature reaches 80 °C (175 °F) to allow the adaptive learn function to initialize.

The generator set is shipped from the factory with the proper level of engine oil and coolant, but each should be checked before the generator set is started. Start and operate the generator set following all the instructions and precautions in the Operator Manual. Ensure that the bonding bolts are installed into the service panels before leaving the site.

NOTICE

Before leaving the site, if the generator set is ready to be placed in service, put the generator set in Auto mode to provide automatic standby power.

NOTICE

Contact your local Cummins service representative if you encounter a fault code.

5.7 InPower Service Tool

The InPower™ service tool can be used in troubleshooting to perform tests, verify control inputs and outputs, and test protective functions. Refer to the InPower User's Guide, provided with the InPower software for test procedures.

5.8 Disabling the AMF Feature

NOTICE

This procedure must be performed by a qualified technician.

On single-phase units, the control is shipped with the Automatic Mains Failure (AMF) feature enabled. This feature has logic to control the RA Automatic Transfer Switch (ATS), including a 5-minute retransfer to utility delay. If you are not using an RA ATS, you can eliminate the 5-minute retransfer to utility delay by disabling the AMF feature using the instructions below.

NOTICE

This procedure is optional. If you do not disable the AMF feature, the generator set will just run for an additional 5 minutes after the utility has been restored.

NOTICE

These steps cannot be performed with the HMI211; they can only be performed with the InPower service tool.

1. Connect to the PCC1302 via InPower.
2. Navigate to the Adjustments->Features->Automatic Transfer Switch folder.
3. Select the Auto Mains Failure Enable parameter.
4. Double-click on Enabled in the Value field.
5. A pop-up will appear with available choices. Select Disabled.
6. Select Device->Save Adjustments from the top menu bar.
7. A pop-up will appear asking if the change is to be saved. Click the Save button.
8. After a pop-up appears confirming that the change has been saved, disconnect InPower from the PCC1302.

This page is intentionally blank.

Appendix A. Fuel Line Selection

Table of Contents

| | |
|---|----|
| Table 14. Required Information for Determining Fuel Line Size | 64 |
| Table 16. Equivalent Lengths of Pipe Fittings and Valves in Feet (Meters) | 65 |
| Table 18. Natural Gas Schedule 40 Metallic Pipe Sizing | 67 |
| Table 20. Natural Gas Semirigid Copper Tubing Sizing | 69 |
| Table 22. Propane Vapor Schedule 40 Metallic Pipe Sizing | 71 |
| Table 24. Propane Vapor Semirigid Copper Tubing Sizing | 72 |
| Table 26. Propane Schedule 40 Iron Pipe Sizing, Liquid Withdrawal (Maximum Capacity of Pipe in Cubic Feet of Gas per Hour)* | 74 |
| Figure 23. Minimum LPG Tank Size (50% Full) Required to Maintain 5 PSIG at Specific Withdrawal Rate and Minimum Expected Winter Temperature | 76 |

A.0 Fuel System Pipe Sizing Introduction

Incorrect fuel line size may cause the generator set to not run or provide full power output.

Tables are included in this section to help calculate pipe sizing for natural gas and propane vapor withdrawal under specified conditions. Consult NFPA 54 or other applicable codes for other operating conditions or other fuel system installation requirements.

Refer to the *Engineering Application Manual T-030: Liquid Cooled Generator Sets* manual (A040S369) for more information.

To determine the optimal fuel line size, the following information is needed:

TABLE 14. REQUIRED INFORMATION FOR DETERMINING FUEL LINE SIZE

| Category | Description |
|---|--|
| Fuel Flow Requirements for the Generator Set | Fuel flow requirements have a large impact on fuel line size. |
| Fuel Source (Natural Gas or Propane Vapor) | Fuel sources can affect fuel line size. Natural gas installations generally require a higher fuel flow rate compared to propane vapor installations, since propane has a higher energy content. |
| Fuel Line Length (Including Fittings) | As fuel line lengths increase, they may require larger diameter fuel lines. Be sure to consider the equivalent length of all of the fittings (elbows, tees, valves) in the installation in addition to the straight pipe length. |
| Fuel Line Type (e.g., Copper Tubing or Iron Pipe) | Most fuel line types are iron pipe or copper tubing. Be sure to use the sizing chart for the fuel line type when sizing the fuel line. |

NOTICE

NFPA 54 has selection tables for other approved fuel lines. Verify with the authorities having jurisdiction the allowed fuel line type for the generator set installation.

A.1 Gas Pipe Sizing

NOTICE

The following tables in this section are reprinted with permission from NFPA 54-2015, *National Fuel Gas Code*, Copyright © 2014, National Fire Protection Association.

- Natural Gas Schedule 40 Metallic Pipe Sizing
- Natural Gas Semirigid Copper Tubing Sizing
- Propane Vapor Schedule 40 Iron Pipe Sizing
- Propane Vapor Semirigid Copper Tubing Sizing
- Propane Schedule 40 Iron Pipe Sizing, Liquid Withdrawal (Maximum Capacity of Pipe in Cubic Feet of Gas per Hour)

This reprinted material is not the complete and official position of the NFPA on the referenced subject, which is represented only by the standard in its entirety.

Sizing of gas piping for proper fuel delivery, both flow and pressure, can become quite complex. A simplified method is to convert all fittings, valves, etc. to equivalent lengths of pipe in the diameter(s) being considered. The total equivalent length can then be related to flow capacity. Equivalent lengths of pipe fittings and valves can be found in the table below.

TABLE 16. EQUIVALENT LENGTHS OF PIPE FITTINGS AND VALVES IN FEET (METERS)

| TYPE OF FITTING | NOMINAL INCH (MILLIMETER) PIPE SIZE | | | | | | | | |
|---|-------------------------------------|--------------|--------------|---------------|---------------|---------------|---------------|---------------|---------------|
| | 1/2 (15) | 3/4 (20) | 1 (25) | 1-1/4 (32) | 1-1/2 (40) | 2 (50) | 2-1/2 (65) | 3 (80) | 4 (100) |
| 90° Std. Elbow or Tee Reduced 1/2. | 1.6 (0.5) | 2.0 (0.6) | 2.6 (0.8) | 3.3 (1.0) | 4.0 (1.2) | 5.0 (1.5) | 6.0 (1.8) | 7.5 (2.3) | 10.0 (3.1) |
| 90° Long Radius Elbow or Straight Run Tee | 1.0 (0.3) | 1.4 (0.4) | 1.7 (0.5) | 2.3 (0.7) | 2.6 (0.8) | 3.3 (1.0) | 4.1 (1.3) | 5.0 (1.5) | 6.7 (2.0) |
| 45° Elbow | 0.8 (0.2) | 0.9 (0.3) | 1.3 (0.4) | 1.7 (0.5) | 2.1 (0.6) | 2.6 (0.8) | 3.2 (1.0) | 4.0 (1.2) | 5.2 (1.6) |
| 180° Std. Bend | 2.5 (0.8) | 3.2 (1.0) | 4.1 (1.2) | 5.6 (1.7) | 6.3 (1.9) | 8.2 (2.5) | 10.0 (3.1) | 12.0 (3.7) | 17.0 (5.2) |
| TEE, Side Inlet or Outlet | 3.0 (0.9) | 4.0 (1.2) | 5.0 (1.5) | 7.0 (2.1) | 8.0 (2.4) | 10.0 (3.0) | 12.0 (3.7) | 15.0 (4.6) | 21.0 (6.4) |

| | | | | | | | | | |
|-------------------------------|---------------|---------------|---------------|----------------|----------------|----------------|----------------|----------------|-----------------|
| Foot Valve and Strainer | 3.7 (1.1) | 4.9 (1.5) | 7.5 (2.3) | 8.9 (2.7) | 11.0 (3.4) | 15.0 (4.6) | 18.0 (5.5) | 22.0 (6.7) | 29.0 (8.8) |
| Swing Check Valve, Fully Open | 6.0 (1.8) | 8.0 (2.4) | 10.0 (3.0) | 14.0 (4.3) | 16.0 (4.9) | 20.0 (6.1) | 25.0 (7.6) | 30.0 (9.1) | 40.0 (12.2) |
| Globe Valve, Fully Open | 18.0 (5.5) | 22.0 (6.7) | 29.0 (8.8) | 38.0 (11.6) | 43.0 (13.1) | 55.0 (16.8) | 69.0 (21.0) | 84.0 (25.6) | 120.0 (36.6) |
| Angle Valve, Fully Open | 7.0 (2.1) | 9.0 (2.7) | 12.0 (3.7) | 15.0 (4.6) | 18.0 (5.5) | 24.0 (7.3) | 29.0 (8.8) | 35.0 (10.7) | 47.0 (14.3) |
| Gate Valve, Fully Open | 0.7 (0.2) | 0.9 (0.3) | 1.0 (0.3) | 1.5 (0.5) | 1.8 (0.5) | 2.3 (0.7) | 2.8 (0.9) | 3.2 (1.0) | 4.5 (1.4) |

The remaining tables in this section show maximum gas capacity for equivalent lengths of various pipe sizes.

Here are some basic but very important steps that all installers must follow to make sure that fuel lines are sized correctly:

1. Verify adequate fuel flow, quality, and pressure available from the natural gas utility connection or the propane system.
2. Obtain the maximum fuel consumption requirements at full load for the specific generator set from the Model Specifications section and for all gas appliances attached to the pipe system.
3. Make a list of all the fittings and valves in the proposed system used in this generator set installation.
4. Determine the equivalent length of all fuel line fittings (elbows, tees, and valves). (See the NFPA Pipe Fittings table in this appendix to determine the equivalent lengths for all fuel line fittings.)
5. Add the equivalent length of the fuel line fittings to the lengths of straight pipe to determine the total equivalent length of the system.
6. Choose the applicable table in this appendix based on the fuel type (natural gas, propane vapor or liquid propane) and fuel line material.
7. Determine the fuel line size at full load:
 - a. Locate the equivalent length of pipe (or next larger equivalent length) in the left hand column.
 - b. Move across the row to where the maximum flow capacity number is as large or larger than the maximum fuel consumption.
 - c. Move to the top of that column to where the minimum nominal pipe size or tubing size required **for the system as designed** is shown.

TABLE 18. NATURAL GAS SCHEDULE 40 METALLIC PIPE SIZING

| | | | | | | | | | | | | | | |
|--------------------------|---|-------|-------|-------|-------|-------|-------|--------|--------|--------|--------|---------|---------|---------|
| Gas: | Natural | | | | | | | | | | | | | |
| Inlet Pressure: | Less than 2 psi | | | | | | | | | | | | | |
| Pressure Drop: | 0.5 in. w.c. | | | | | | | | | | | | | |
| Specific Gravity: | 0.60 | | | | | | | | | | | | | |
| | Pipe Size (in.) | | | | | | | | | | | | | |
| Nominal : | 1/2 | 3/4 | 1 | 1 1/4 | 1 1/2 | 2 | 2 1/2 | 3 | 4 | 5 | 6 | 8 | 10 | 12 |
| Actual ID: | 0.622 | 0.824 | 1.049 | 1.380 | 1.610 | 2.067 | 2.469 | 3.068 | 4.026 | 5.047 | 6.065 | 7.981 | 10.020 | 11.938 |
| Length (ft) | Capacity in Cubic Feet of Gas per Hour | | | | | | | | | | | | | |
| 10 | 172 | 360 | 678 | 1,390 | 2,090 | 4,020 | 6,400 | 11,300 | 23,100 | 41,800 | 67,600 | 139,000 | 252,000 | 399,000 |
| 20 | 118 | 247 | 466 | 957 | 1,430 | 2,760 | 4,400 | 7,780 | 15,900 | 28,700 | 46,500 | 95,500 | 173,000 | 275,000 |
| 30 | 95 | 199 | 374 | 768 | 1,150 | 2,220 | 3,530 | 6,250 | 12,700 | 23,000 | 37,300 | 76,700 | 139,000 | 220,000 |
| 40 | 81 | 170 | 320 | 657 | 985 | 1,900 | 3,020 | 5,350 | 10,900 | 19,700 | 31,900 | 65,600 | 119,000 | 189,000 |
| 50 | 72 | 151 | 284 | 583 | 873 | 1,680 | 2,680 | 4,740 | 9,660 | 17,500 | 28,300 | 58,200 | 106,000 | 167,000 |
| 60 | 65 | 137 | 257 | 528 | 791 | 1,520 | 2,430 | 4,290 | 8,760 | 15,800 | 25,600 | 52,700 | 95,700 | 152,000 |
| 70 | 60 | 126 | 237 | 486 | 728 | 1,400 | 2,230 | 3,950 | 8,050 | 14,600 | 23,600 | 48,500 | 88,100 | 139,000 |
| 80 | 56 | 117 | 220 | 452 | 677 | 1,300 | 2,080 | 3,670 | 7,490 | 13,600 | 22,000 | 45,100 | 81,900 | 130,000 |
| 90 | 52 | 110 | 207 | 424 | 635 | 1,220 | 1,950 | 3,450 | 7,030 | 12,700 | 20,600 | 42,300 | 76,900 | 122,000 |
| 100 | 50 | 104 | 195 | 400 | 600 | 1,160 | 1,840 | 3,260 | 6,640 | 12,000 | 19,500 | 40,000 | 72,600 | 115,000 |
| 125 | 44 | 92 | 173 | 355 | 532 | 1,020 | 1,630 | 2,890 | 5,890 | 10,600 | 17,200 | 35,400 | 64,300 | 102,000 |
| 150 | 40 | 83 | 157 | 322 | 482 | 928 | 1,480 | 2,610 | 5,330 | 9,650 | 15,600 | 32,100 | 58,300 | 92,300 |
| 175 | 37 | 77 | 144 | 296 | 443 | 854 | 1,360 | 2,410 | 4,910 | 8,880 | 14,400 | 29,500 | 53,600 | 84,900 |

| | | | | | | | | | | | | | | |
|-------|----|----|-----|-----|-----|-----|-------|-------|-------|-------|--------|--------|--------|--------|
| 200 | 34 | 71 | 134 | 275 | 412 | 794 | 1,270 | 2,240 | 4,560 | 8,260 | 13,400 | 27,500 | 49,900 | 79,000 |
| 250 | 30 | 63 | 119 | 244 | 366 | 704 | 1,120 | 1,980 | 4,050 | 7,320 | 11,900 | 24,300 | 44,200 | 70,000 |
| 300 | 27 | 57 | 108 | 221 | 331 | 638 | 1,020 | 1,800 | 3,670 | 6,630 | 10,700 | 22,100 | 40,100 | 63,400 |
| 350 | 25 | 53 | 99 | 203 | 305 | 587 | 935 | 1,650 | 3,370 | 6,100 | 9,880 | 20,300 | 36,900 | 58,400 |
| 400 | 23 | 49 | 92 | 189 | 283 | 546 | 870 | 1,540 | 3,140 | 5,680 | 9,190 | 18,900 | 34,300 | 54,300 |
| 450 | 22 | 46 | 86 | 177 | 266 | 512 | 816 | 1,440 | 2,940 | 5,330 | 8,620 | 17,700 | 32,200 | 50,900 |
| 500 | 21 | 43 | 82 | 168 | 251 | 484 | 771 | 1,360 | 2,780 | 5,030 | 8,150 | 16,700 | 30,400 | 48,100 |
| 550 | 20 | 41 | 78 | 159 | 239 | 459 | 732 | 1,290 | 2,640 | 4,780 | 7,740 | 15,900 | 28,900 | 45,700 |
| 600 | 19 | 39 | 74 | 152 | 228 | 438 | 699 | 1,240 | 2,520 | 4,560 | 7,380 | 15,200 | 27,500 | 43,600 |
| 650 | 18 | 38 | 71 | 145 | 218 | 420 | 669 | 1,180 | 2,410 | 4,360 | 7,070 | 14,500 | 26,400 | 41,800 |
| 700 | 17 | 36 | 68 | 140 | 209 | 403 | 643 | 1,140 | 2,320 | 4,190 | 6,790 | 14,000 | 25,300 | 40,100 |
| 750 | 17 | 35 | 66 | 135 | 202 | 389 | 619 | 1,090 | 2,230 | 4,040 | 6,540 | 13,400 | 24,400 | 38,600 |
| 800 | 16 | 34 | 63 | 130 | 195 | 375 | 598 | 1,060 | 2,160 | 3,900 | 6,320 | 13,000 | 23,600 | 37,300 |
| 850 | 16 | 33 | 61 | 126 | 189 | 363 | 579 | 1,020 | 2,090 | 3,780 | 6,110 | 12,600 | 22,800 | 36,100 |
| 900 | 15 | 32 | 59 | 122 | 183 | 352 | 561 | 992 | 2,020 | 3,660 | 5,930 | 12,200 | 22,100 | 35,000 |
| 950 | 15 | 31 | 58 | 118 | 178 | 342 | 545 | 963 | 1,960 | 3,550 | 5,760 | 11,800 | 21,500 | 34,000 |
| 1,000 | 14 | 30 | 56 | 115 | 173 | 333 | 530 | 937 | 1,910 | 3,460 | 5,600 | 11,500 | 20,900 | 33,100 |
| 1,100 | 14 | 28 | 53 | 109 | 164 | 316 | 503 | 890 | 1,810 | 3,280 | 5,320 | 10,900 | 19,800 | 31,400 |
| 1,200 | 13 | 27 | 51 | 104 | 156 | 301 | 480 | 849 | 1,730 | 3,130 | 5,070 | 10,400 | 18,900 | 30,000 |

| | | | | | | | | | | | | | | |
|-----------|----|----|----|-----|-----|-----|-----|-----|-----------|-----------|-----------|-----------|------------|------------|
| 1,30 0 | 12 | 26 | 49 | 100 | 150 | 289 | 460 | 813 | 1,66 0 | 3,00 0 | 4,86 0 | 9,98 0 | 18,1 00 | 28,7 00 |
| 1,40 0 | 12 | 25 | 47 | 96 | 144 | 277 | 442 | 781 | 1,59 0 | 2,88 0 | 4,67 0 | 9,59 0 | 17,4 00 | 27,6 00 |
| 1,50 0 | 11 | 24 | 45 | 93 | 139 | 267 | 426 | 752 | 1,53 0 | 2,78 0 | 4,50 0 | 9,24 0 | 16,8 00 | 26,6 00 |
| 1,60 0 | 11 | 23 | 44 | 89 | 134 | 258 | 411 | 727 | 1,48 0 | 2,68 0 | 4,34 0 | 8,92 0 | 16,2 00 | 25,6 00 |
| 1,70 0 | 11 | 22 | 42 | 86 | 130 | 250 | 398 | 703 | 1,43 0 | 2,59 0 | 4,20 0 | 8,63 0 | 15,7 00 | 24,8 00 |
| 1,80 0 | 10 | 22 | 41 | 84 | 126 | 242 | 386 | 682 | 1,39 0 | 2,52 0 | 4,07 0 | 8,37 0 | 15,2 00 | 24,1 00 |
| 1,90 0 | 10 | 21 | 40 | 81 | 122 | 235 | 375 | 662 | 1,35 0 | 2,44 0 | 3,96 0 | 8,13 0 | 14,8 00 | 23,4 00 |
| 2,00 0 | NA | 20 | 39 | 79 | 119 | 229 | 364 | 644 | 1,31 0 | 2,38 0 | 3,85 0 | 7,91 0 | 14,4 00 | 22,7 00 |

NA: Applies to a flow of less than 10 cfh.

Note: All table entries are rounded to 3 significant digits.

TABLE 20. NATURAL GAS SEMIRIGID COPPER TUBING SIZING

| | | | | | | | | | |
|-------------------------------|---|-------|-------|-------|-------|-------|-------|-------|-------|
| Gas: | Natural | | | | | | | | |
| Inlet Pressure: | Less than 2 psi | | | | | | | | |
| Pressure Drop: | 0.5 in. w.c. | | | | | | | | |
| Specific Gravity: | 0.60 | | | | | | | | |
| | Tube Size (in.) | | | | | | | | |
| Nominal K & L: | 1/4 | 3/8 | 1/2 | 5/8 | 3/4 | 1 | 1 1/4 | 1 1/2 | 2 |
| Nominal ACR: | 3/8 | 1/2 | 5/8 | 3/4 | 7/8 | 1 1/8 | 1 3/8 | — | — |
| Outside: | 0.375 | 0.500 | 0.625 | 0.750 | 0.875 | 1.125 | 1.375 | 1.625 | 2.125 |
| Inside:* | 0.305 | 0.402 | 0.527 | 0.652 | 0.745 | 0.995 | 1.245 | 1.481 | 1.959 |
| Length (ft.) | Capacity in Cubic Feet of Gas per Hour | | | | | | | | |
| 10 | 27 | 55 | 111 | 195 | 276 | 590 | 1,060 | 1,680 | 3,490 |
| 20 | 18 | 38 | 77 | 134 | 190 | 406 | 730 | 1,150 | 2,400 |
| 30 | 15 | 30 | 61 | 107 | 152 | 326 | 586 | 925 | 1,930 |

| | | | | | | | | | |
|-------|----|----|----|----|-----|-----|-----|-----|-------|
| 40 | 13 | 26 | 53 | 92 | 131 | 279 | 502 | 791 | 1,650 |
| 50 | 11 | 23 | 47 | 82 | 116 | 247 | 445 | 701 | 1,460 |
| 60 | 10 | 21 | 42 | 74 | 105 | 224 | 403 | 635 | 1,320 |
| 70 | NA | 19 | 39 | 68 | 96 | 206 | 371 | 585 | 1,220 |
| 80 | NA | 18 | 36 | 63 | 90 | 192 | 345 | 544 | 1,130 |
| 90 | NA | 17 | 34 | 59 | 84 | 180 | 324 | 510 | 1,060 |
| 100 | NA | 16 | 32 | 56 | 79 | 170 | 306 | 482 | 1,000 |
| 125 | NA | 14 | 28 | 50 | 70 | 151 | 271 | 427 | 890 |
| 150 | NA | 13 | 26 | 45 | 64 | 136 | 245 | 387 | 806 |
| 175 | NA | 12 | 24 | 41 | 59 | 125 | 226 | 356 | 742 |
| 200 | NA | 11 | 22 | 39 | 55 | 117 | 210 | 331 | 690 |
| 250 | NA | NA | 20 | 34 | 48 | 103 | 186 | 294 | 612 |
| 300 | NA | NA | 18 | 31 | 44 | 94 | 169 | 266 | 554 |
| 350 | NA | NA | 16 | 28 | 40 | 86 | 155 | 245 | 510 |
| 400 | NA | NA | 15 | 26 | 38 | 80 | 144 | 228 | 474 |
| 450 | NA | NA | 14 | 25 | 35 | 75 | 135 | 214 | 445 |
| 500 | NA | NA | 13 | 23 | 33 | 71 | 128 | 202 | 420 |
| 550 | NA | NA | 13 | 22 | 32 | 68 | 122 | 192 | 399 |
| 600 | NA | NA | 12 | 21 | 30 | 64 | 116 | 183 | 381 |
| 650 | NA | NA | 12 | 20 | 29 | 62 | 111 | 175 | 365 |
| 700 | NA | NA | 11 | 20 | 28 | 59 | 107 | 168 | 350 |
| 750 | NA | NA | 11 | 19 | 27 | 57 | 103 | 162 | 338 |
| 800 | NA | NA | 10 | 18 | 26 | 55 | 99 | 156 | 326 |
| 850 | NA | NA | 10 | 18 | 25 | 53 | 96 | 151 | 315 |
| 900 | NA | NA | NA | 17 | 24 | 52 | 93 | 147 | 306 |
| 950 | NA | NA | NA | 17 | 24 | 50 | 90 | 143 | 297 |
| 1,000 | NA | NA | NA | 16 | 23 | 49 | 88 | 139 | 289 |
| 1,100 | NA | NA | NA | 15 | 22 | 46 | 84 | 132 | 274 |
| 1,200 | NA | NA | NA | 15 | 21 | 44 | 80 | 126 | 262 |
| 1,300 | NA | NA | NA | 14 | 20 | 42 | 76 | 120 | 251 |
| 1,400 | NA | NA | NA | 13 | 19 | 41 | 73 | 116 | 241 |
| 1,500 | NA | NA | NA | 13 | 18 | 39 | 71 | 111 | 232 |

| | | | | | | | | | |
|-------|----|----|----|----|----|----|----|-----|-----|
| 1,600 | NA | NA | NA | 13 | 18 | 38 | 68 | 108 | 224 |
| 1,700 | NA | NA | NA | 12 | 17 | 37 | 66 | 104 | 217 |
| 1,800 | NA | NA | NA | 12 | 17 | 36 | 64 | 101 | 210 |
| 1,900 | NA | NA | NA | 11 | 16 | 35 | 62 | 98 | 204 |
| 2,000 | NA | NA | NA | 11 | 16 | 34 | 60 | 95 | 199 |

NA: A flow of less than 10 cfh.

Note: All table entries are rounded to 3 significant digits.

*Table capacities are based on Type K copper tubing inside diameter (shown), which has the smallest inside diameter of the copper tubing products.

TABLE 22. PROPANE VAPOR SCHEDULE 40 METALLIC PIPE SIZING

| | | | | | | | | | |
|---|--|-------------------|-------|-------|-------|-------|--------|--------|--------|
| Gas: | | Undiluted Propane | | | | | | | |
| Inlet Pressure: | | 11.0 in. w.c. | | | | | | | |
| Pressure Drop: | | 0.5 in. w.c. | | | | | | | |
| Specific Gravity: | | 1.50 | | | | | | | |
| INTENDED USE: Pipe Sizing Between Single- or Second-Stage (Low-Pressure) Regulator and Appliance | | | | | | | | | |
| | Pipe Size (in.) | | | | | | | | |
| Nominal Inside: | 1/2 | 3/4 | 1 | 1 1/4 | 1 1/2 | 2 | 2 1/2 | 3 | 4 |
| Actual: | 0.622 | 0.824 | 1.049 | 1.380 | 1.610 | 2.067 | 2.469 | 3.068 | 4.026 |
| Length (ft.) | Capacity in Thousands of BTU per Hour | | | | | | | | |
| 10 | 291 | 608 | 1,150 | 2,350 | 3,520 | 6,790 | 10,800 | 19,100 | 39,000 |
| 20 | 200 | 418 | 787 | 1,620 | 2,420 | 4,660 | 7,430 | 13,100 | 26,800 |
| 30 | 160 | 336 | 632 | 1,300 | 1,940 | 3,750 | 5,970 | 10,600 | 21,500 |
| 40 | 137 | 287 | 541 | 1,110 | 1,660 | 3,210 | 5,110 | 9,030 | 18,400 |
| 50 | 122 | 255 | 480 | 985 | 1,480 | 2,840 | 4,530 | 8,000 | 16,300 |
| 60 | 110 | 231 | 434 | 892 | 1,340 | 2,570 | 4,100 | 7,250 | 14,800 |
| 80 | 101 | 212 | 400 | 821 | 1,230 | 2,370 | 3,770 | 6,670 | 13,600 |
| 100 | 94 | 197 | 372 | 763 | 1,140 | 2,200 | 3,510 | 6,210 | 12,700 |
| 125 | 89 | 185 | 349 | 716 | 1,070 | 2,070 | 3,290 | 5,820 | 11,900 |
| 150 | 84 | 175 | 330 | 677 | 1,010 | 1,950 | 3,110 | 5,500 | 11,200 |
| 175 | 74 | 155 | 292 | 600 | 899 | 1,730 | 2,760 | 4,880 | 9,950 |

| | | | | | | | | | |
|-------|----|-----|-----|-----|-----|-------|-------|-------|-------|
| 200 | 67 | 140 | 265 | 543 | 814 | 1,570 | 2,500 | 4,420 | 9,010 |
| 250 | 62 | 129 | 243 | 500 | 749 | 1,440 | 2,300 | 4,060 | 8,290 |
| 300 | 58 | 120 | 227 | 465 | 697 | 1,340 | 2,140 | 3,780 | 7,710 |
| 350 | 51 | 107 | 201 | 412 | 618 | 1,190 | 1,900 | 3,350 | 6,840 |
| 400 | 46 | 97 | 182 | 373 | 560 | 1,080 | 1,720 | 3,040 | 6,190 |
| 450 | 42 | 89 | 167 | 344 | 515 | 991 | 1,580 | 2,790 | 5,700 |
| 500 | 40 | 83 | 156 | 320 | 479 | 922 | 1,470 | 2,600 | 5,300 |
| 550 | 37 | 78 | 146 | 300 | 449 | 865 | 1,380 | 2,440 | 4,970 |
| 600 | 35 | 73 | 138 | 283 | 424 | 817 | 1,300 | 2,300 | 4,700 |
| 650 | 33 | 70 | 131 | 269 | 403 | 776 | 1,240 | 2,190 | 4,460 |
| 700 | 32 | 66 | 125 | 257 | 385 | 741 | 1,180 | 2,090 | 4,260 |
| 750 | 30 | 64 | 120 | 246 | 368 | 709 | 1,130 | 2,000 | 4,080 |
| 800 | 29 | 61 | 115 | 236 | 354 | 681 | 1,090 | 1,920 | 3,920 |
| 850 | 28 | 59 | 111 | 227 | 341 | 656 | 1,050 | 1,850 | 3,770 |
| 900 | 27 | 57 | 107 | 220 | 329 | 634 | 1,010 | 1,790 | 3,640 |
| 950 | 26 | 55 | 104 | 213 | 319 | 613 | 978 | 1,730 | 3,530 |
| 1,000 | 25 | 53 | 100 | 206 | 309 | 595 | 948 | 1,680 | 3,420 |
| 1,100 | 25 | 52 | 97 | 200 | 300 | 578 | 921 | 1,630 | 3,320 |
| 1,200 | 24 | 50 | 95 | 195 | 292 | 562 | 895 | 1,580 | 3,230 |
| 1,300 | 23 | 48 | 90 | 185 | 277 | 534 | 850 | 1,500 | 3,070 |
| 1,400 | 22 | 46 | 86 | 176 | 264 | 509 | 811 | 1,430 | 2,930 |
| 1,500 | 21 | 44 | 82 | 169 | 253 | 487 | 777 | 1,370 | 2,800 |
| 1,600 | 20 | 42 | 79 | 162 | 243 | 468 | 746 | 1,320 | 2,690 |
| 1,700 | 19 | 40 | 76 | 156 | 234 | 451 | 719 | 1,270 | 2,590 |
| 1,800 | 19 | 39 | 74 | 151 | 226 | 436 | 694 | 1,230 | 2,500 |
| 1,900 | 18 | 38 | 71 | 146 | 219 | 422 | 672 | 1,190 | 2,420 |
| 2,000 | 18 | 37 | 69 | 142 | 212 | 409 | 652 | 1,150 | 2,350 |

Note: All table entries are rounded to 3 significant digits.

TABLE 24. PROPANE VAPOR SEMIRIGID COPPER TUBING SIZING

| | |
|------------------------|-------------------|
| Gas: | Undiluted Propane |
| Inlet Pressure: | 11.0 in. w.c. |

| | | | | | | | | | |
|---|--|--------------|-------|-------|-------|-------|-------|-------|-------|
| Pressure Drop: | | 0.5 in. w.c. | | | | | | | |
| Specific Gravity: | | 1.50 | | | | | | | |
| INTENDED USE: Tube Sizing Between Single- or Second-Stage (Low-Pressure) Regulator and Appliance | | | | | | | | | |
| | Tube Size (in.) | | | | | | | | |
| Nominal K & L: | 1/4 | 3/8 | 1/2 | 5/8 | 3/4 | 1 | 1 1/4 | 1 1/2 | 2 |
| Nominal ACR: | 3/8 | 1/2 | 5/8 | 3/4 | 7/8 | 1 1/8 | 1 3/8 | — | — |
| Outside: | 0.375 | 0.500 | 0.625 | 0.750 | 0.875 | 1.125 | 1.375 | 1.625 | 2.125 |
| Inside:* | 0.305 | 0.402 | 0.527 | 0.652 | 0.745 | 0.995 | 1.245 | 1.481 | 1.959 |
| Length (ft.) | Capacity in Thousands of BTU per Hour | | | | | | | | |
| 10 | 45 | 93 | 188 | 329 | 467 | 997 | 1,800 | 2,830 | 5,890 |
| 20 | 31 | 64 | 129 | 226 | 321 | 685 | 1,230 | 1,950 | 4,050 |
| 30 | 25 | 51 | 104 | 182 | 258 | 550 | 991 | 1,560 | 3,250 |
| 40 | 21 | 44 | 89 | 155 | 220 | 471 | 848 | 1,340 | 2,780 |
| 50 | 19 | 39 | 79 | 138 | 195 | 417 | 752 | 1,180 | 2,470 |
| 60 | 17 | 35 | 71 | 125 | 177 | 378 | 681 | 1,070 | 2,240 |
| 70 | 16 | 32 | 66 | 115 | 163 | 348 | 626 | 988 | 2,060 |
| 80 | 15 | 30 | 61 | 107 | 152 | 324 | 583 | 919 | 1,910 |
| 90 | 14 | 28 | 57 | 100 | 142 | 304 | 547 | 862 | 1,800 |
| 100 | 13 | 27 | 54 | 95 | 134 | 287 | 517 | 814 | 1,700 |
| 125 | 11 | 24 | 48 | 84 | 119 | 254 | 458 | 722 | 1,500 |
| 150 | 10 | 21 | 44 | 76 | 108 | 230 | 415 | 654 | 1,360 |
| 175 | NA | 20 | 40 | 70 | 99 | 212 | 382 | 602 | 1,250 |
| 200 | NA | 18 | 37 | 65 | 92 | 197 | 355 | 560 | 1,170 |
| 250 | NA | 16 | 33 | 58 | 82 | 175 | 315 | 496 | 1,030 |
| 300 | NA | 15 | 30 | 52 | 74 | 158 | 285 | 449 | 936 |
| 350 | NA | 14 | 28 | 48 | 68 | 146 | 262 | 414 | 861 |
| 400 | NA | 13 | 26 | 45 | 63 | 136 | 244 | 385 | 801 |
| 450 | NA | 12 | 24 | 42 | 60 | 127 | 229 | 361 | 752 |
| 500 | NA | 11 | 23 | 40 | 56 | 120 | 216 | 341 | 710 |
| 550 | NA | 11 | 22 | 38 | 53 | 114 | 205 | 324 | 674 |

| | | | | | | | | | |
|-------|----|----|----|----|----|-----|-----|-----|-----|
| 600 | NA | 10 | 21 | 36 | 51 | 109 | 196 | 309 | 643 |
| 650 | NA | NA | 20 | 34 | 49 | 104 | 188 | 296 | 616 |
| 700 | NA | NA | 19 | 33 | 47 | 100 | 180 | 284 | 592 |
| 750 | NA | NA | 18 | 32 | 45 | 96 | 174 | 274 | 570 |
| 800 | NA | NA | 18 | 31 | 44 | 93 | 168 | 264 | 551 |
| 850 | NA | NA | 17 | 30 | 42 | 90 | 162 | 256 | 533 |
| 900 | NA | NA | 17 | 29 | 41 | 87 | 157 | 248 | 517 |
| 950 | NA | NA | 16 | 28 | 40 | 85 | 153 | 241 | 502 |
| 1,000 | NA | NA | 16 | 27 | 39 | 83 | 149 | 234 | 488 |
| 1,100 | NA | NA | 15 | 26 | 37 | 78 | 141 | 223 | 464 |
| 1,200 | NA | NA | 14 | 25 | 35 | 75 | 135 | 212 | 442 |
| 1,300 | NA | NA | 14 | 24 | 34 | 72 | 129 | 203 | 423 |
| 1,400 | NA | NA | 13 | 23 | 32 | 69 | 124 | 195 | 407 |
| 1,500 | NA | NA | 13 | 22 | 31 | 66 | 119 | 188 | 392 |
| 1,600 | NA | NA | 12 | 21 | 30 | 64 | 115 | 182 | 378 |
| 1,700 | NA | NA | 12 | 20 | 29 | 62 | 112 | 176 | 366 |
| 1,800 | NA | NA | 11 | 20 | 28 | 60 | 108 | 170 | 355 |
| 1,900 | NA | NA | 11 | 19 | 27 | 58 | 105 | 166 | 345 |
| 2,000 | NA | NA | 11 | 19 | 27 | 57 | 102 | 161 | 335 |

NA: A flow of less than 10,000 BTU/hr.

Note: All table entries are rounded to 3 significant digits.

*Table capacities are based on Type K copper tubing inside diameter (shown), which has the smallest inside diameter of the copper tubing products.

TABLE 26. PROPANE SCHEDULE 40 IRON PIPE SIZING, LIQUID WITHDRAWAL (MAXIMUM CAPACITY OF PIPE IN CUBIC FEET OF GAS PER HOUR)*

| Equivalent Length of Pipe (ft.) | Schedule 40 Iron Pipe Size (in.): Nominal (Inside Diameter) | | | | | | | | |
|---------------------------------|---|----------------|--------------|-----------------|-----------------|--------------|--------------|------------------|--------------|
| | 1/2 (0.622) | 3/4 (0.824) | 1 (1.049) | 1 1/4 (1.38) | 1 1/2 (1.61) | 2 (2.067) | 3 (3.068) | 3 1/2 (3.548) | 4 (4.026) |
| 30 | 733 | 1,532 | 2,885 | 5,924 | 8,876 | 17,094 | 48,164 | 70,519 | 98,238 |
| 40 | 627 | 1,311 | 2,469 | 5,070 | 7,597 | 14,630 | 41,222 | 60,355 | 84,079 |

| Equivalent Length of Pipe (ft.) | Schedule 40 Iron Pipe Size (in.): Nominal (Inside Diameter) | | | | | | | | |
|---------------------------------|---|-------------|-----------|--------------|--------------|-----------|-----------|---------------|-----------|
| | 1/2 (0.622) | 3/4 (0.824) | 1 (1.049) | 1 1/4 (1.38) | 1 1/2 (1.61) | 2 (2.067) | 3 (3.068) | 3 1/2 (3.548) | 4 (4.026) |
| 50 | 556 | 1,162 | 2,189 | 4,494 | 6,733 | 12,966 | 36,534 | 53,492 | 74,518 |
| 60 | 504 | 1,053 | 1,983 | 4,072 | 6,100 | 11,748 | 33,103 | 48,467 | 67,519 |
| 70 | 463 | 969 | 1,824 | 3,746 | 5,612 | 10,808 | 30,454 | 44,589 | 62,116 |
| 80 | 431 | 901 | 1,697 | 3,484 | 5,221 | 10,055 | 28,331 | 41,482 | 57,787 |
| 90 | 404 | 845 | 1,593 | 3,269 | 4,899 | 9,434 | 26,583 | 38,921 | 54,220 |
| 100 | 382 | 798 | 1,504 | 3,088 | 4,627 | 8,912 | 25,110 | 36,764 | 51,216 |
| 150 | 307 | 641 | 1,208 | 2,480 | 3,716 | 7,156 | 20,164 | 29,523 | 41,128 |
| 200 | 262 | 549 | 1,034 | 2,122 | 3,180 | 6,125 | 17,258 | 25,268 | 35,200 |
| 250 | 233 | 486 | 916 | 1,881 | 2,819 | 5,428 | 15,295 | 22,395 | 31,198 |
| 300 | 211 | 441 | 830 | 1,705 | 2,554 | 4,919 | 13,859 | 20,291 | 28,267 |
| 350 | 194 | 405 | 764 | 1,568 | 2,349 | 4,525 | 12,750 | 18,667 | 26,006 |
| 400 | 180 | 377 | 711 | 1,459 | 2,186 | 4,209 | 11,861 | 17,366 | 24,193 |
| 450 | 169 | 354 | 667 | 1,369 | 2,051 | 3,950 | 11,129 | 16,295 | 22,700 |
| 500 | 160 | 334 | 630 | 1,293 | 1,937 | 3,731 | 10,512 | 15,391 | 21,442 |
| 600 | 145 | 303 | 571 | 1,172 | 1,755 | 3,380 | 9,525 | 13,946 | 19,428 |
| 700 | 133 | 279 | 525 | 1,078 | 1,615 | 3,110 | 8,763 | 12,830 | 17,873 |
| 800 | 124 | 259 | 488 | 1,003 | 1,502 | 2,893 | 8,152 | 11,936 | 16,628 |

| Equivalent Length of Pipe (ft.) | Schedule 40 Iron Pipe Size (in.): Nominal (Inside Diameter) | | | | | | | | |
|---------------------------------|---|-------------|-----------|--------------|--------------|-----------|-----------|---------------|-----------|
| | 1/2 (0.622) | 3/4 (0.824) | 1 (1.049) | 1 1/4 (1.38) | 1 1/2 (1.61) | 2 (2.067) | 3 (3.068) | 3 1/2 (3.548) | 4 (4.026) |
| 900 | 116 | 243 | 458 | 941 | 1,409 | 2,715 | 7,649 | 11,199 | 15,601 |
| 1000 | 110 | 230 | 433 | 889 | 1,331 | 2,564 | 7,225 | 10,579 | 14,737 |
| 1500 | 88 | 184 | 348 | 713 | 1,069 | 2,059 | 5,802 | 8,495 | 11,834 |
| 2000 | 76 | 158 | 297 | 611 | 915 | 1,762 | 4,966 | 7,271 | 10,128 |

*Pipe size recommendations are based on schedule 40 black iron pipe.

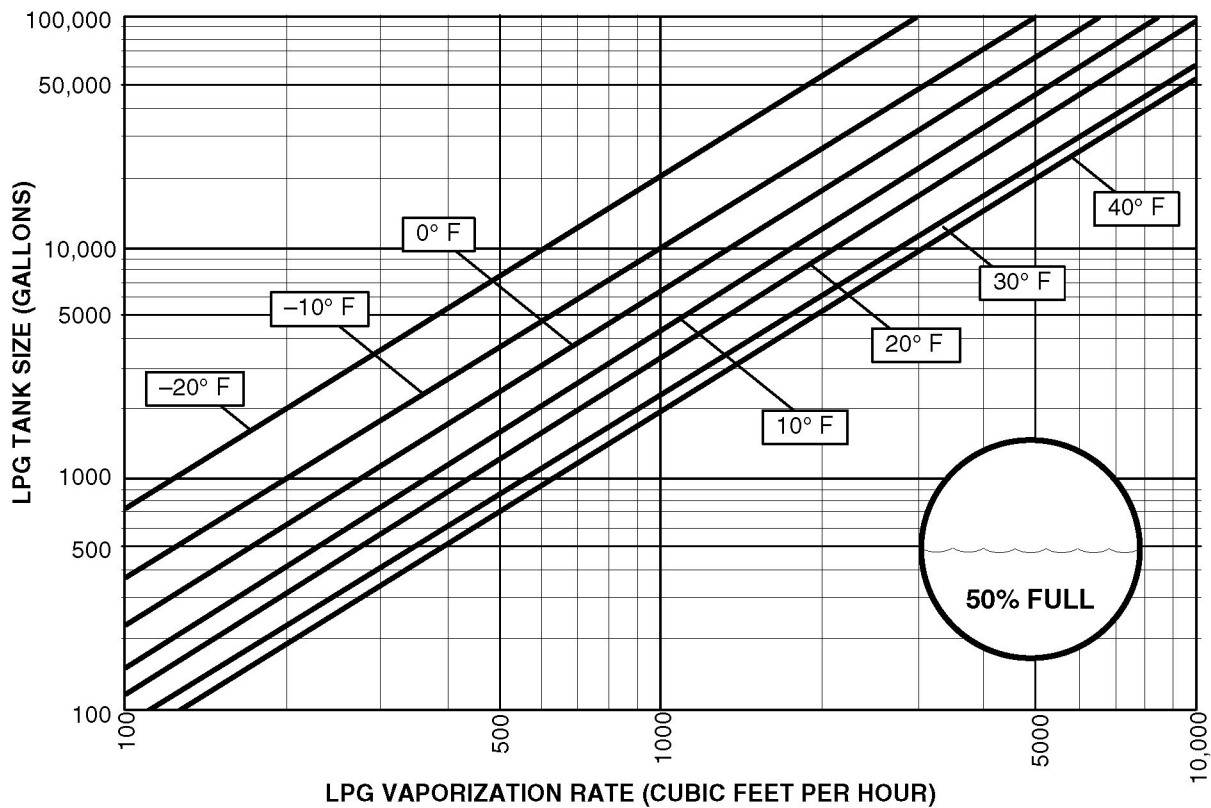

FIGURE 23. MINIMUM LPG TANK SIZE (50% FULL) REQUIRED TO MAINTAIN 5 PSIG AT SPECIFIC WITHDRAWAL RATE AND MINIMUM EXPECTED WINTER TEMPERATURE

Appendix B. Outline and System Drawings

Table of Contents

| | |
|--|----|
| Figure 24. Generator Set Outline, 45-50 kW (Sheet 1 of 2) | 79 |
| Figure 25. Generator Set Outline, 45-50 kW (Sheet 2 of 2) | 80 |
| Figure 26. Generator Set Outline, 60 kW (Sheet 1 of 2) | 81 |
| Figure 27. Generator Set Outline, 60 kW (Sheet 2 of 2) | 82 |
| Figure 28. Generator Set Outline, 70-100 kW (Sheet 1 of 2) | 83 |
| Figure 29. Generator Set Outline, 70-100 kW (Sheet 2 of 2) | 84 |
| Figure 30. Generator Set Outline, Accessories (Sheet 1 of 2) | 85 |
| Figure 31. Generator Set Outline, Accessories (Sheet 2 of 2) | 86 |
| Figure 32. Foundation Outline (Sheet 1 of 1) | 87 |
| Figure 33. Enclosure Outline, Weather (Sheet 1 of 1) | 88 |
| Figure 34. Enclosure Outline, Sound Attention Level 1 and Level 2 (Sheet 1 of 2) | 89 |
| Figure 35. Enclosure Outline, Sound Attention Level 1 and Level 2 (Sheet 2 of 2) | 90 |

This page is intentionally blank.

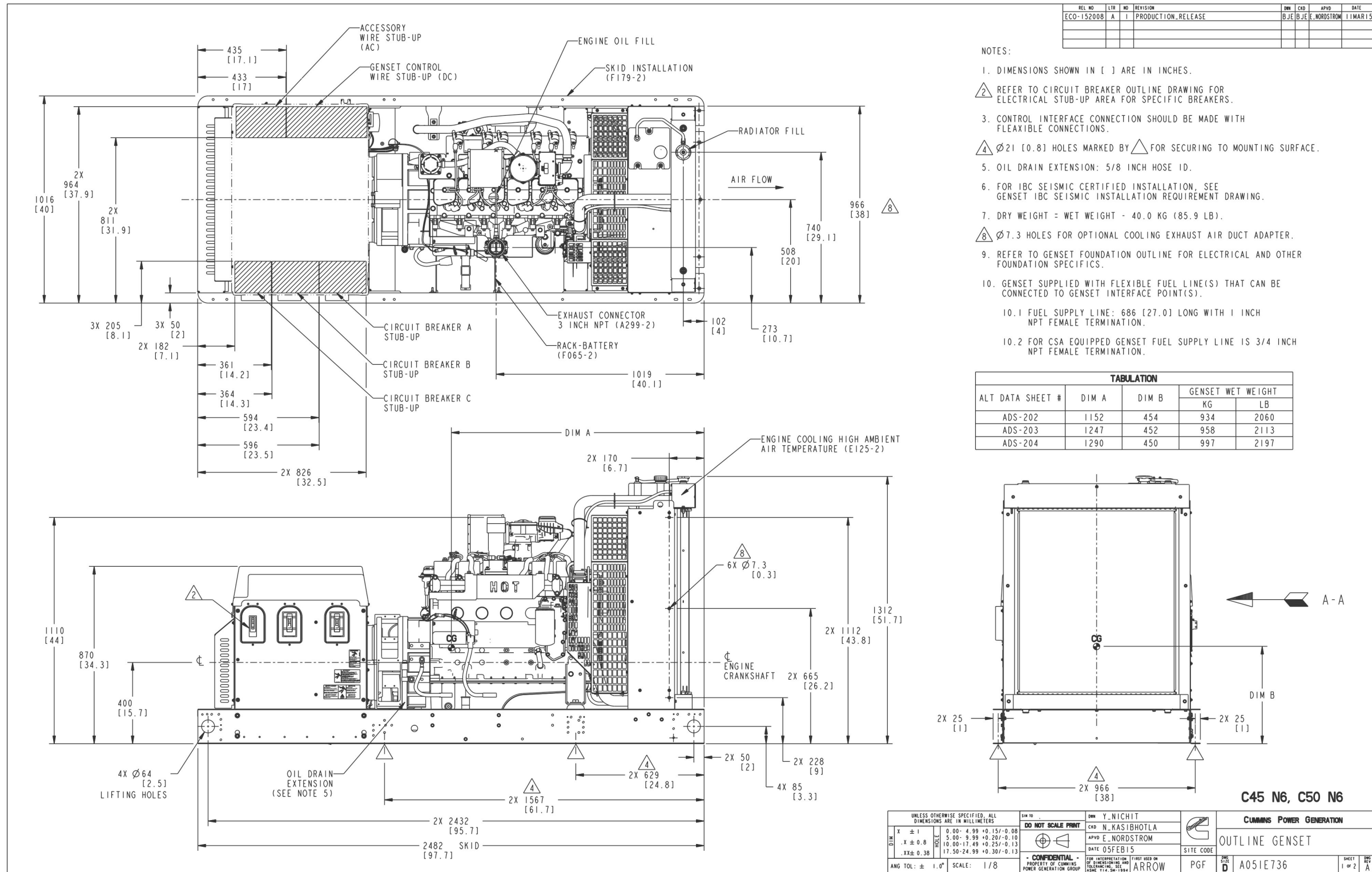

FIGURE 24. GENERATOR SET OUTLINE, 45-50 KW (SHEET 1 OF 2)

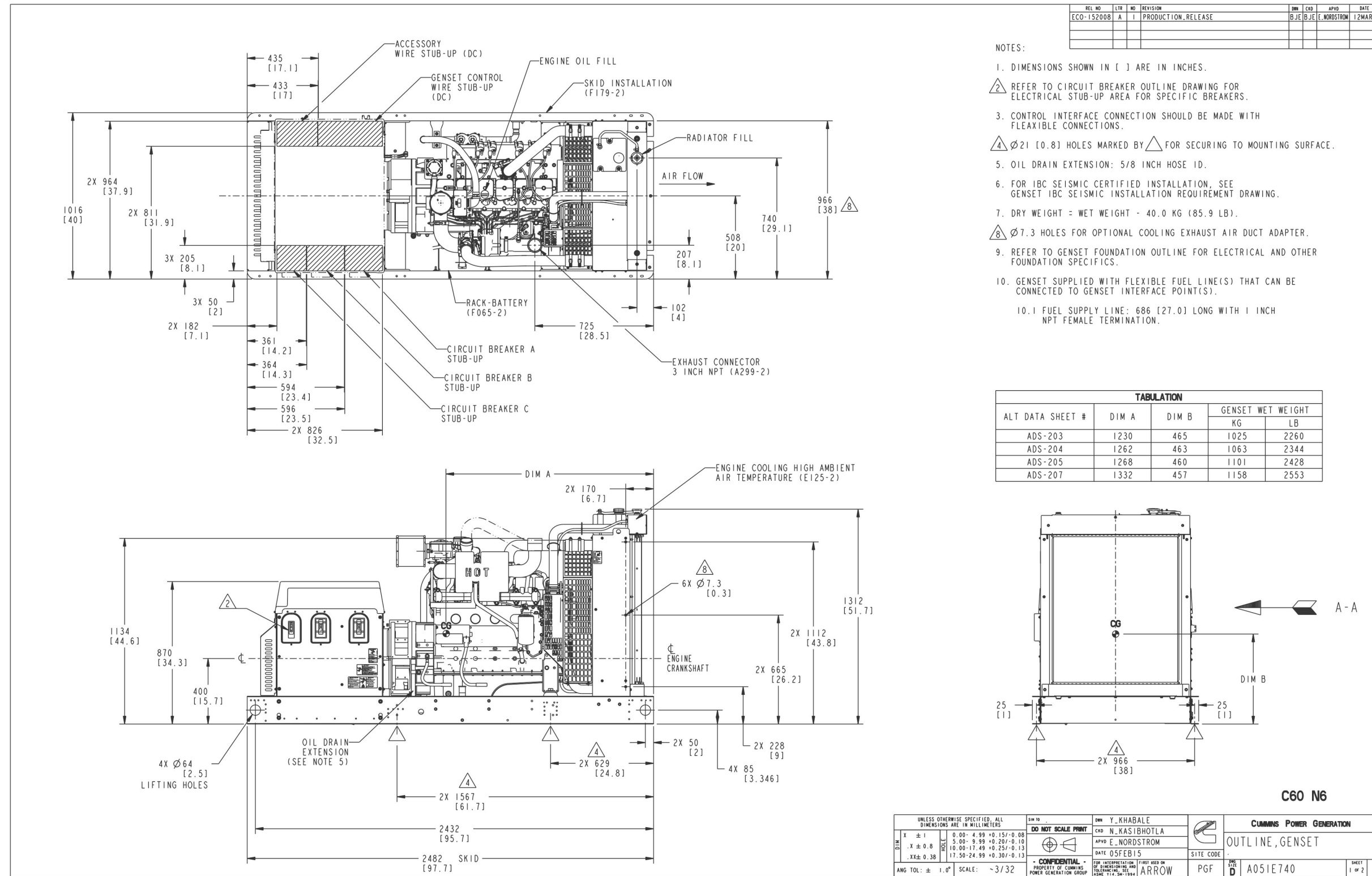

FIGURE 26. GENERATOR SET OUTLINE, 60 KW (SHEET 1 OF 2)

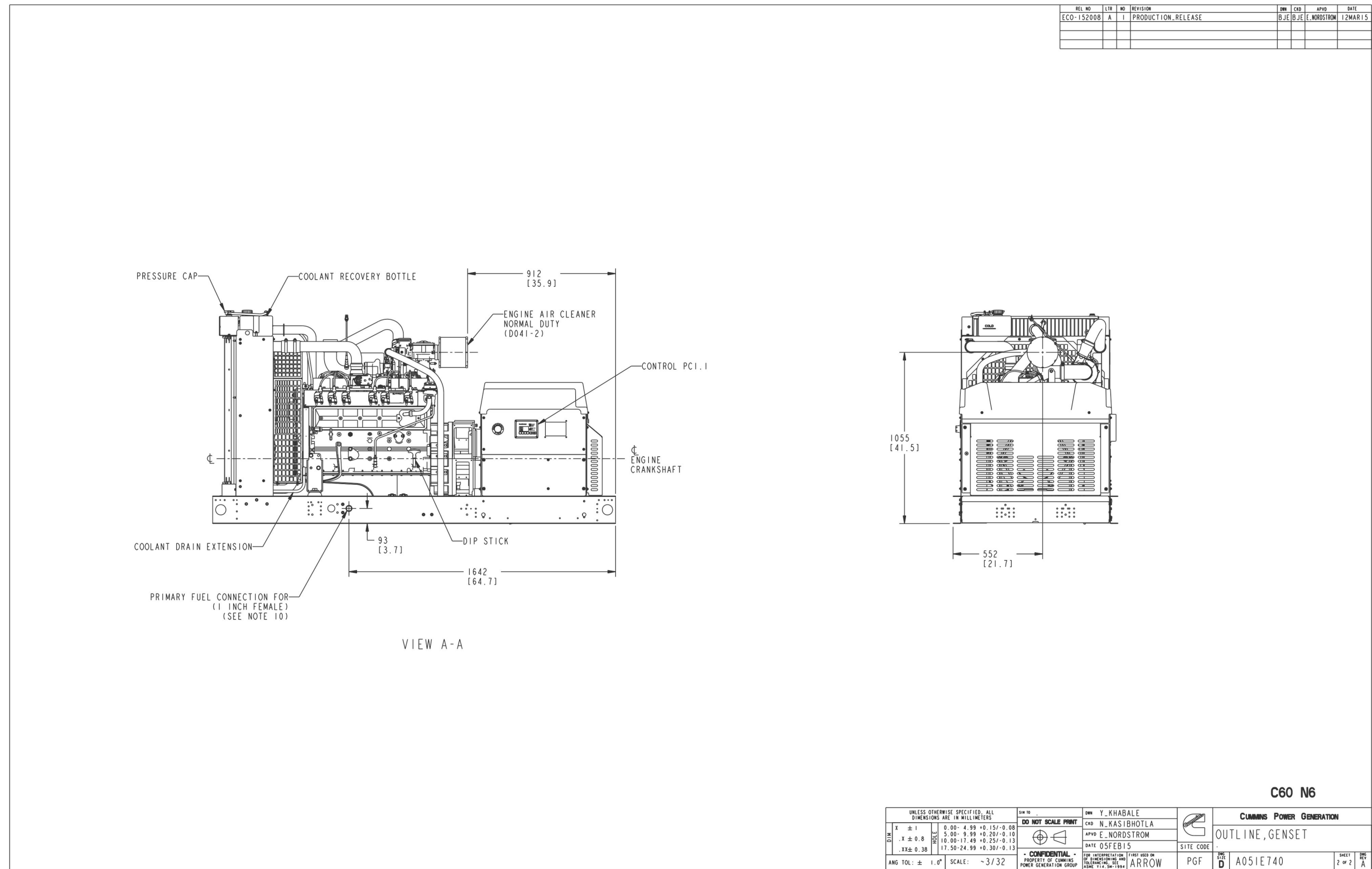

FIGURE 27. GENERATOR SET OUTLINE, 60 KW (SHEET 2 OF 2)

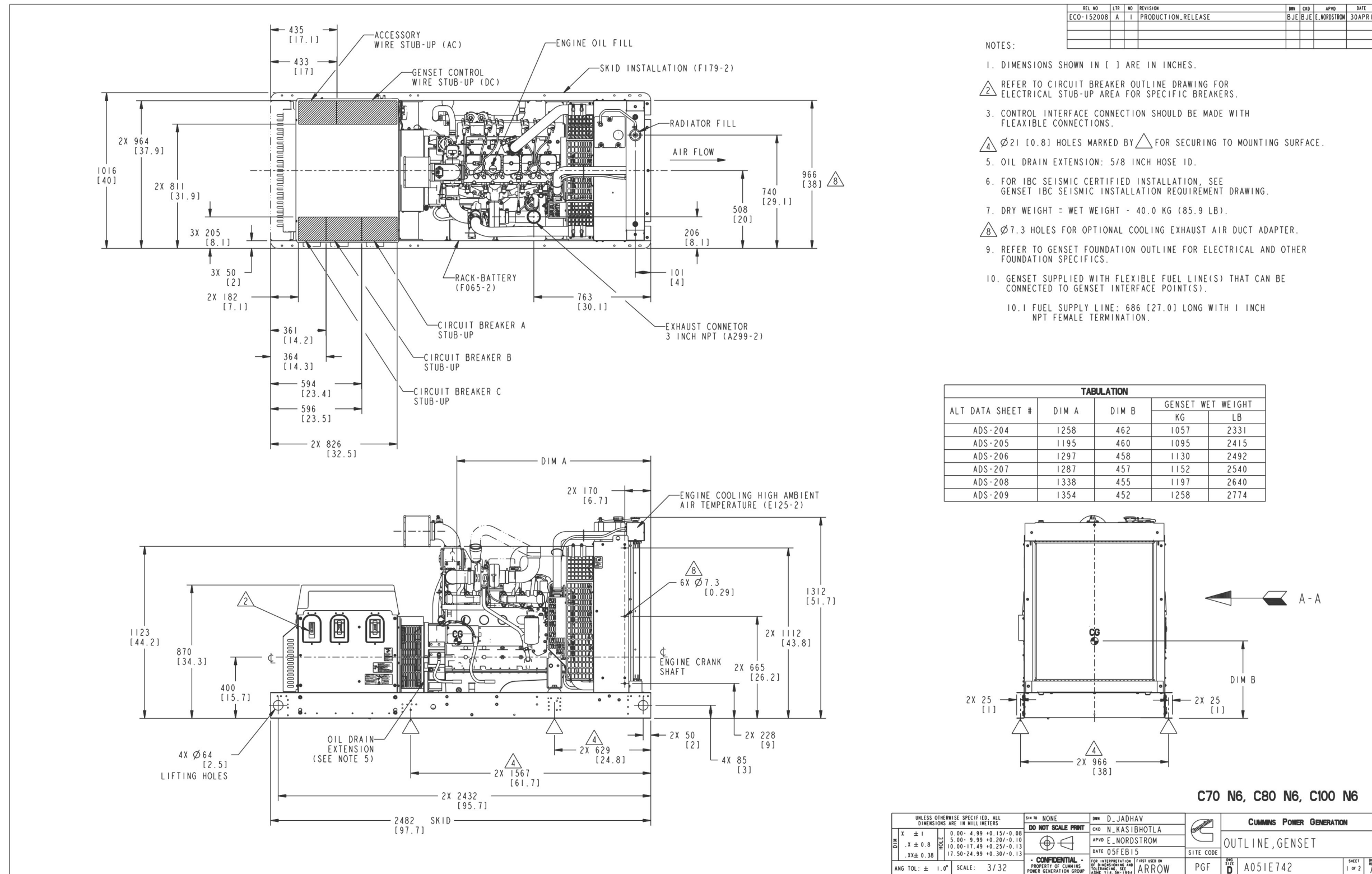

FIGURE 28. GENERATOR SET OUTLINE, 70-100 KW (SHEET 1 OF 2)

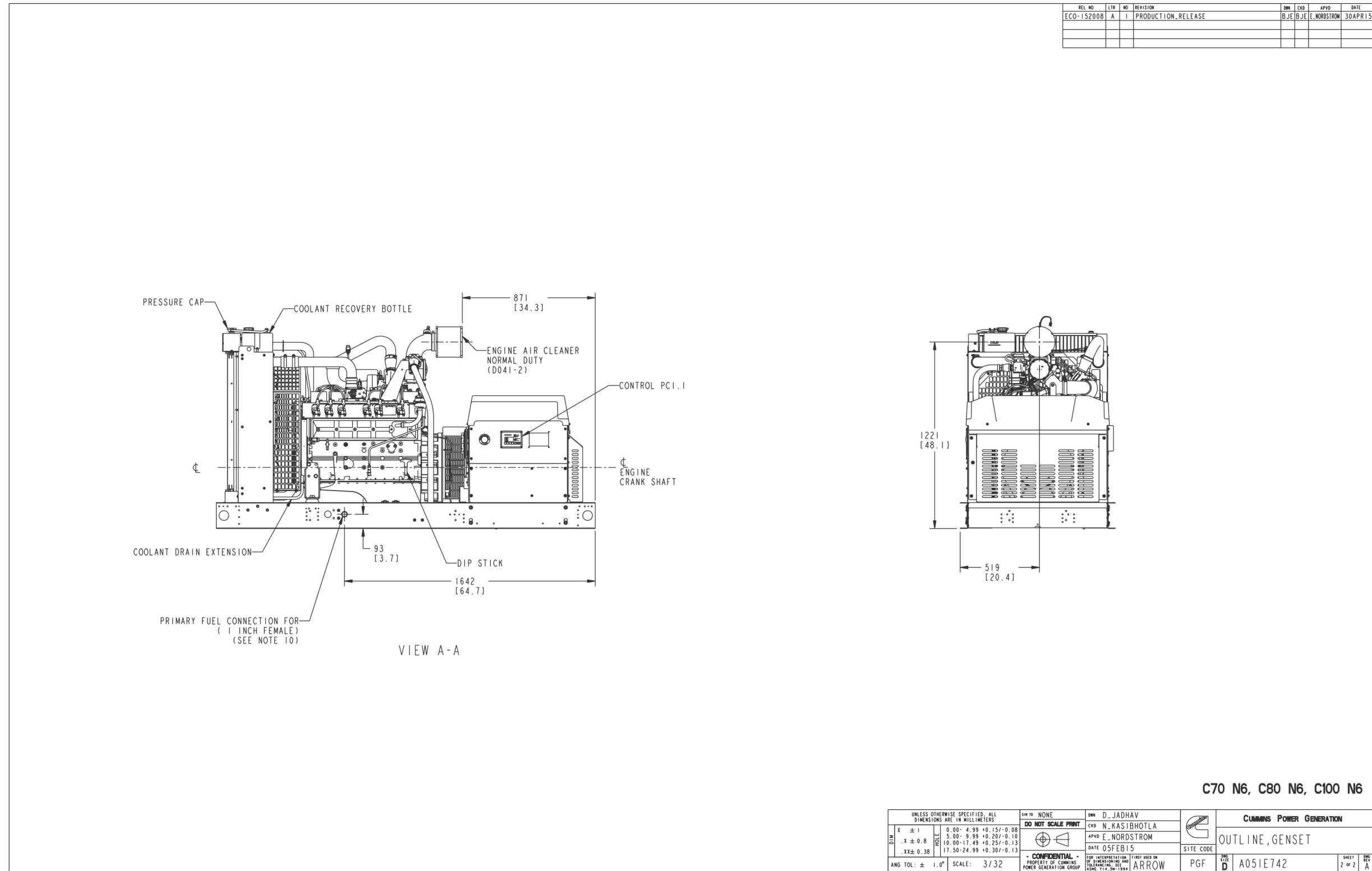

FIGURE 29. GENERATOR SET OUTLINE, 70-100 KW (SHEET 2 OF 2)

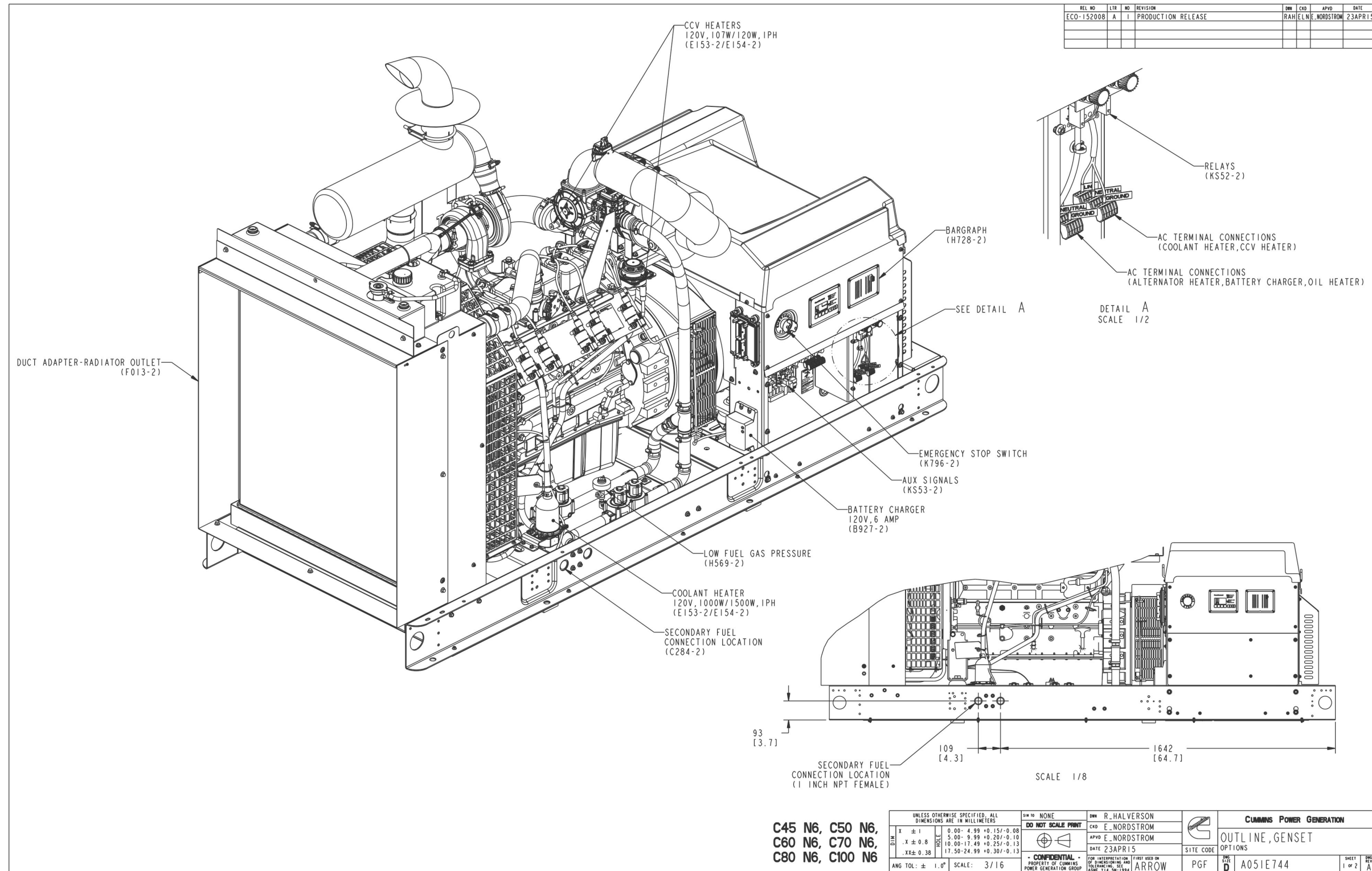

FIGURE 30. GENERATOR SET OUTLINE, ACCESSORIES (SHEET 1 OF 2)

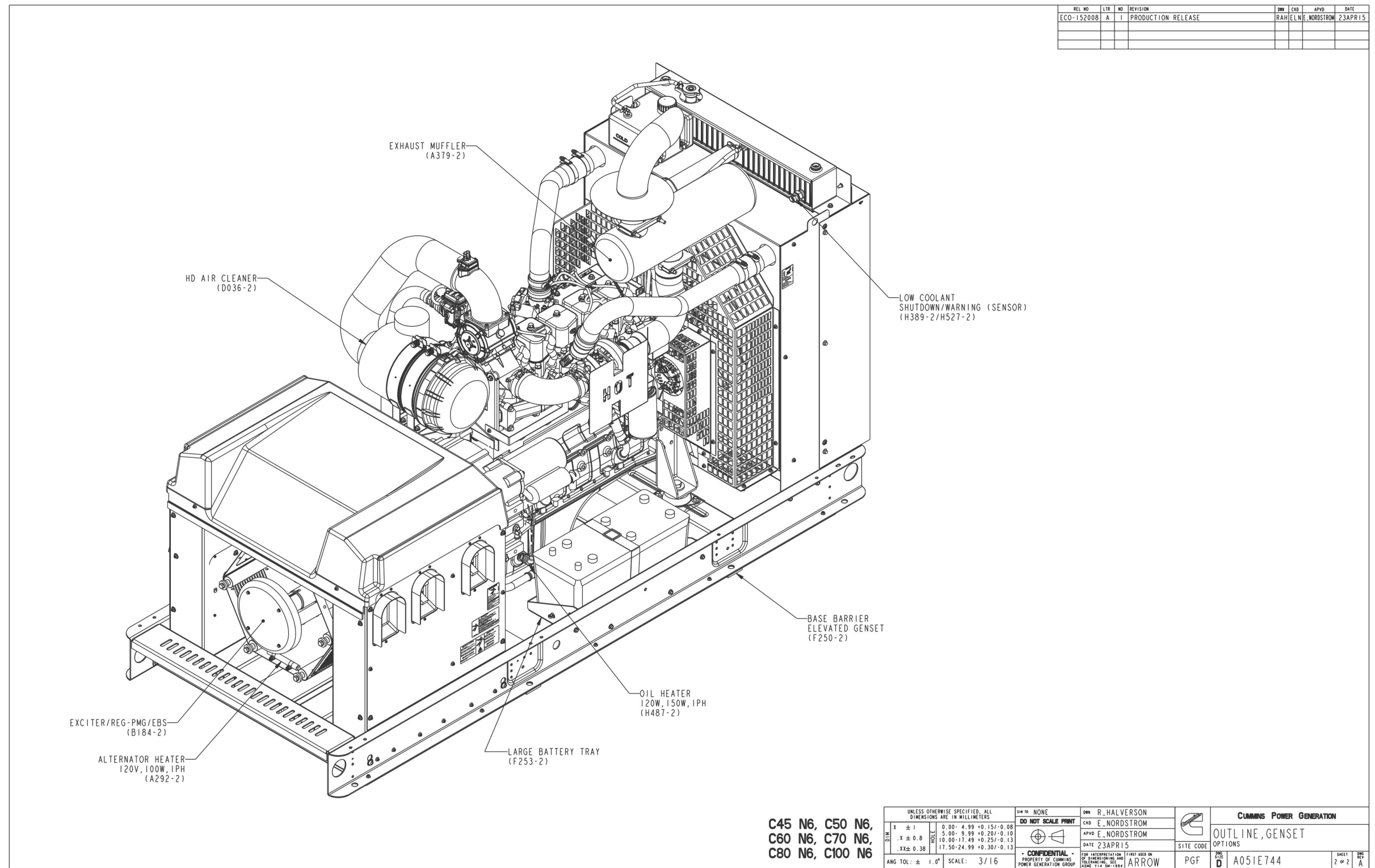

FIGURE 31. GENERATOR SET OUTLINE, ACCESSORIES (SHEET 2 OF 2)

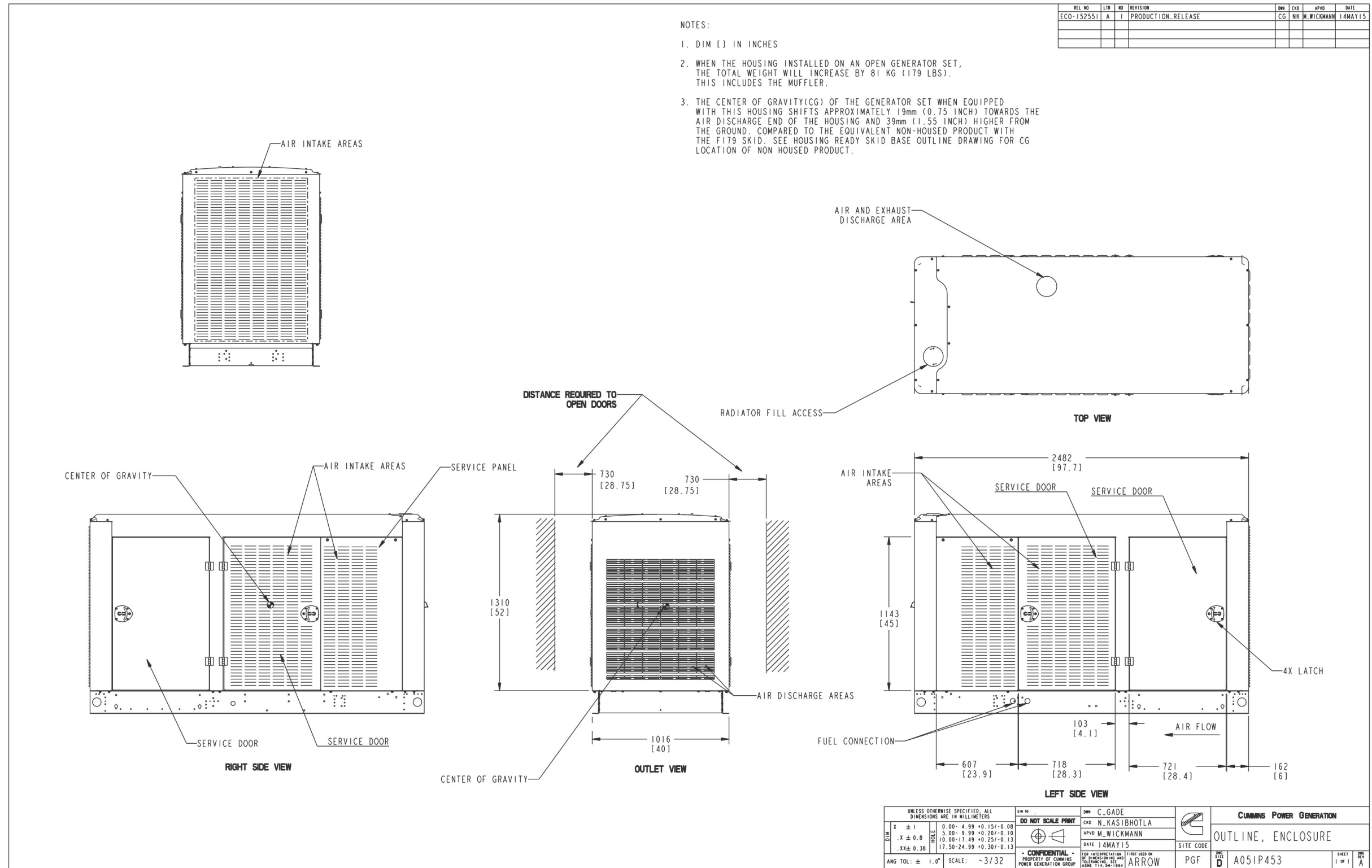

FIGURE 33. ENCLOSURE OUTLINE, WEATHER (SHEET 1 OF 1)

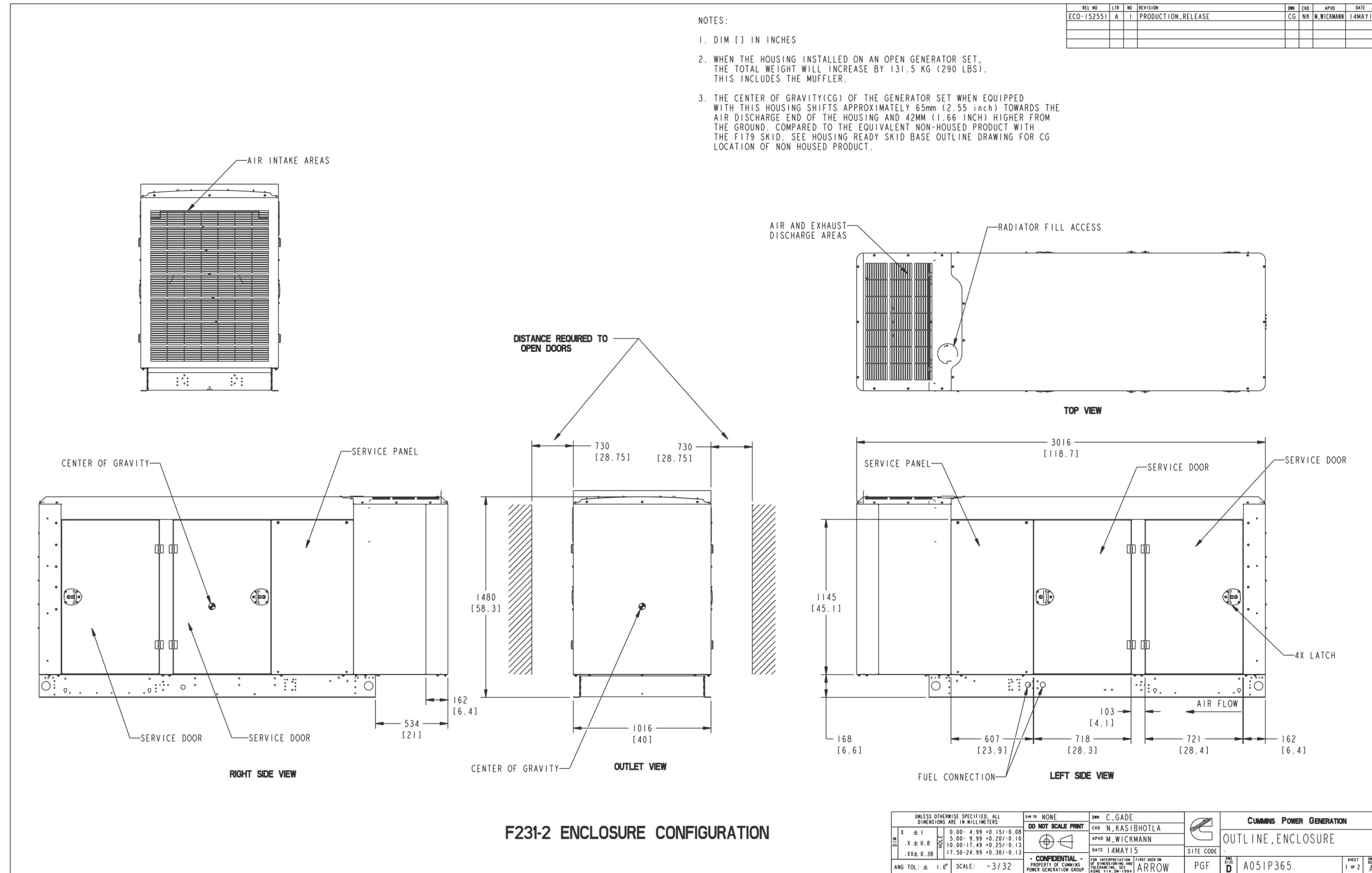

FIGURE 34. ENCLOSURE OUTLINE, SOUND ATTENTION LEVEL 1 AND LEVEL 2 (SHEET 1 OF 2)

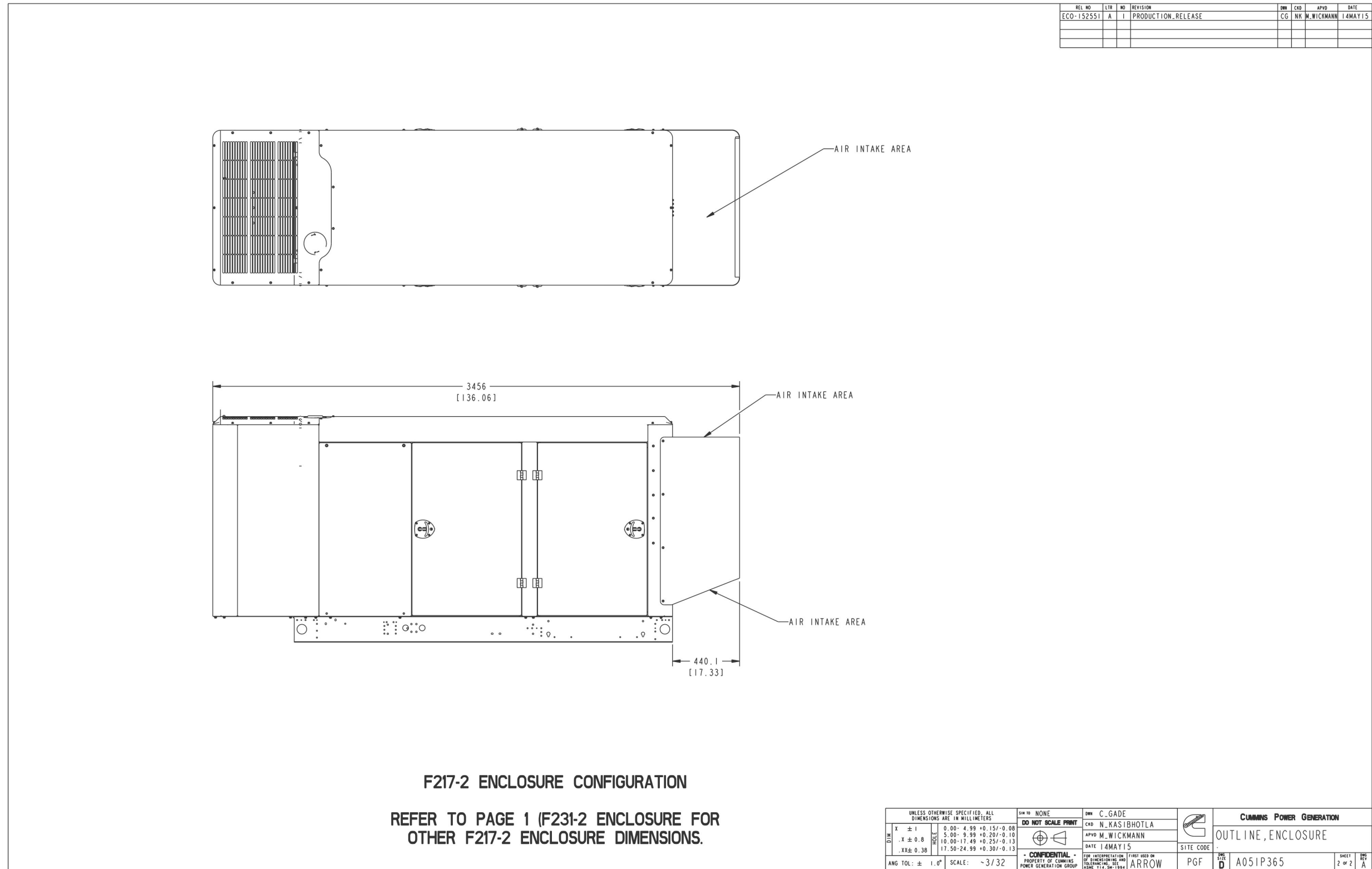

FIGURE 35. ENCLOSURE OUTLINE, SOUND ATTENTION LEVEL 1 AND LEVEL 2 (SHEET 2 OF 2)

Appendix C. Wiring Diagrams

Table of Contents

| | |
|--|-----|
| Figure 36. Wiring Diagram for PCC 1302 (56 Pin ECM) (Sheet 1 of 7) | 95 |
| Figure 37. Wiring Diagram for PCC 1302 (56 Pin ECM) (Sheet 2 of 7) | 96 |
| Figure 38. Wiring Diagram for PCC 1302 (56 Pin ECM) (Sheet 3 of 7) | 97 |
| Figure 39. Wiring Diagram for PCC 1302 (56 Pin ECM) (Sheet 4 of 7) | 98 |
| Figure 40. Wiring Diagram for PCC 1302 (56 Pin ECM) (Sheet 5 of 7) | 99 |
| Figure 41. Wiring Diagram for PCC 1302 (56 Pin ECM) (Sheet 6 of 7) | 100 |
| Figure 42. Wiring Diagram for PCC 1302 (56 Pin ECM) (Sheet 7 of 7) | 101 |
| Figure 43. Wiring Diagram for PCC 1302 (90 Pin ECM) (Sheet 1 of 7) | 102 |
| Figure 44. Wiring Diagram for PCC 1302 (90 Pin ECM) (Sheet 2 of 7) | 103 |
| Figure 45. Wiring Diagram for PCC 1302 (90 Pin ECM) (Sheet 3 of 7) | 104 |
| Figure 46. Wiring Diagram for PCC 1302 (90 Pin ECM) (Sheet 4 of 7) | 105 |
| Figure 47. Wiring Diagram for PCC 1302 (90 Pin ECM) (Sheet 5 of 7) | 106 |
| Figure 48. Wiring Diagram for PCC 1302 (90 Pin ECM) (Sheet 6 of 7) | 107 |
| Figure 49. Wiring Diagram for PCC 1302 (90 Pin ECM) (Sheet 7 of 7) | 108 |
| Figure 50. Wiring Diagram for PCC 2300 (56 Pin ECM) (Sheet 1 of 7) | 109 |
| Figure 51. Wiring Diagram for PCC 2300 (56 Pin ECM) (Sheet 2 of 7) | 110 |
| Figure 52. Wiring Diagram for PCC 2300 (56 Pin ECM) (Sheet 3 of 7) | 111 |
| Figure 53. Wiring Diagram for PCC 2300 (56 Pin ECM) (Sheet 4 of 7) | 112 |
| Figure 54. Wiring Diagram for PCC 2300 (56 Pin ECM) (Sheet 5 of 7) | 113 |
| Figure 55. Wiring Diagram for PCC 2300 (56 Pin ECM) (Sheet 6 of 7) | 114 |
| Figure 56. Wiring Diagram for PCC 2300 (56 Pin ECM) (Sheet 7 of 7) | 115 |
| Figure 57. Wiring Diagram for PCC 2300 (90 Pin ECM) (Sheet 1 of 7) | 116 |
| Figure 58. Wiring Diagram for PCC 2300 (90 Pin ECM) (Sheet 2 of 7) | 117 |
| Figure 59. Wiring Diagram for PCC 2300 (90 Pin ECM) (Sheet 3 of 7) | 118 |
| Figure 60. Wiring Diagram for PCC 2300 (90 Pin ECM) (Sheet 4 of 7) | 119 |
| Figure 61. Wiring Diagram for PCC 2300 (90 Pin ECM) (Sheet 5 of 7) | 120 |
| Figure 62. Wiring Diagram for PCC 2300 (90 Pin ECM) (Sheet 6 of 7) | 121 |
| Figure 63. Wiring Diagram for PCC 2300 (90 Pin ECM) (Sheet 7 of 7) | 122 |
| Figure 64. Circuit Breaker Outline (Sheet 1 of 3) | 123 |
| Figure 65. Circuit Breaker Outline (Sheet 2 of 3) | 124 |
| Figure 66. Circuit Breaker Outline (Sheet 3 of 3) | 125 |
| Figure 67. PCC 1302/2300 (Sheet 1 of 3) | 126 |
| Figure 68. PCC 1302/2300 (Sheet 2 of 3) | 127 |
| Figure 69. PCC 1302/2300 (Sheet 3 of 3) | 128 |

| | |
|---|------------|
| Figure 70. Circuit Card Harness (Sheet 1 of 1) | 129 |
| Figure 71. Relay Harness (Sheet 1 of 1) | 130 |
| Figure 72. Generator Electrical Harness (Sheet 1 of 1) | 131 |

The drawings included in this section are representative. For current complete information, refer to the drawing package that was shipped with the unit.

This page is intentionally blank.

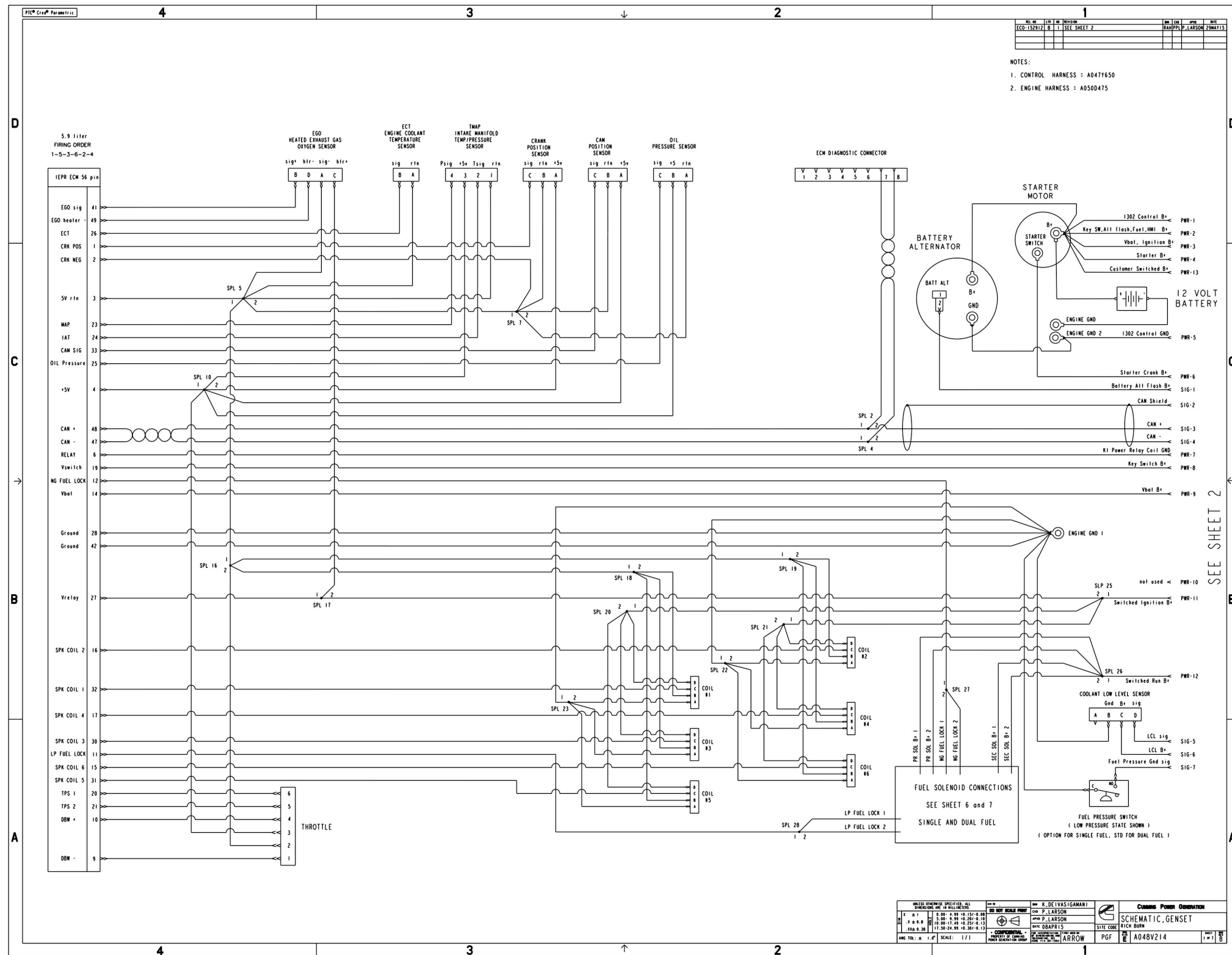

FIGURE 36. WIRING DIAGRAM FOR PCC 1302 (56 PIN ECM) (SHEET 1 OF 7)

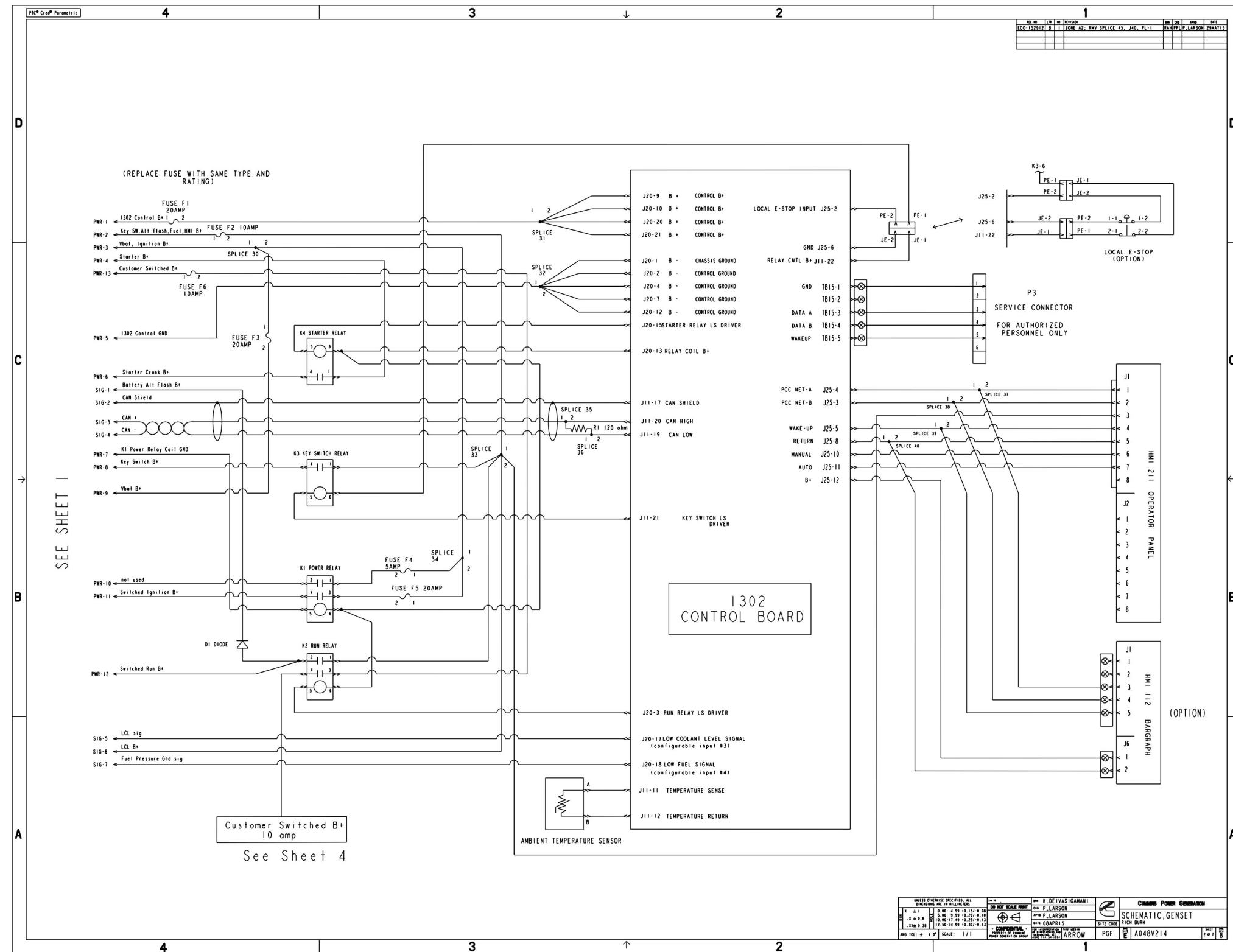

FIGURE 37. WIRING DIAGRAM FOR PCC 1302 (56 PIN ECM) (SHEET 2 OF 7)

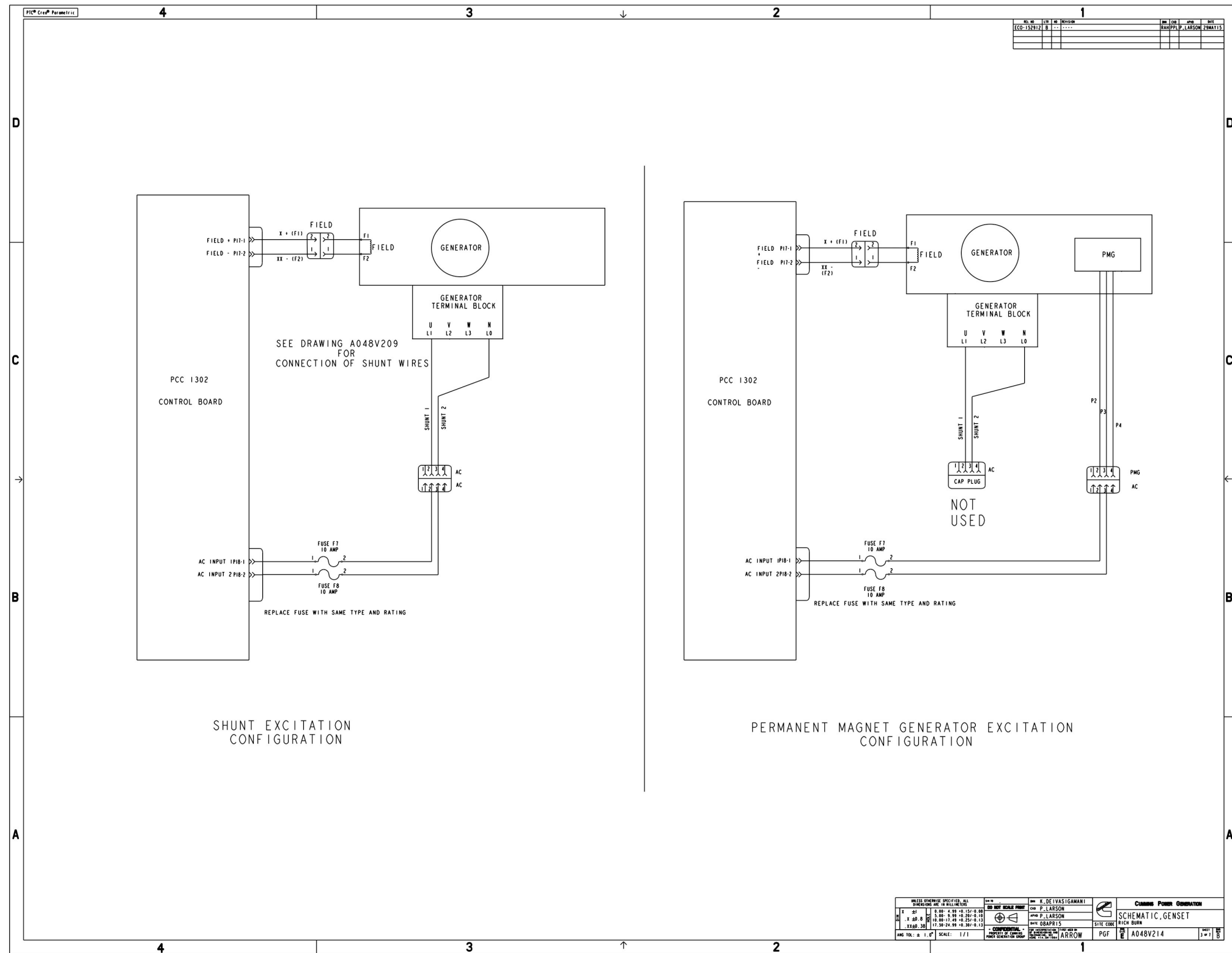

FIGURE 38. WIRING DIAGRAM FOR PCC 1302 (56 PIN ECM) (SHEET 3 OF 7)

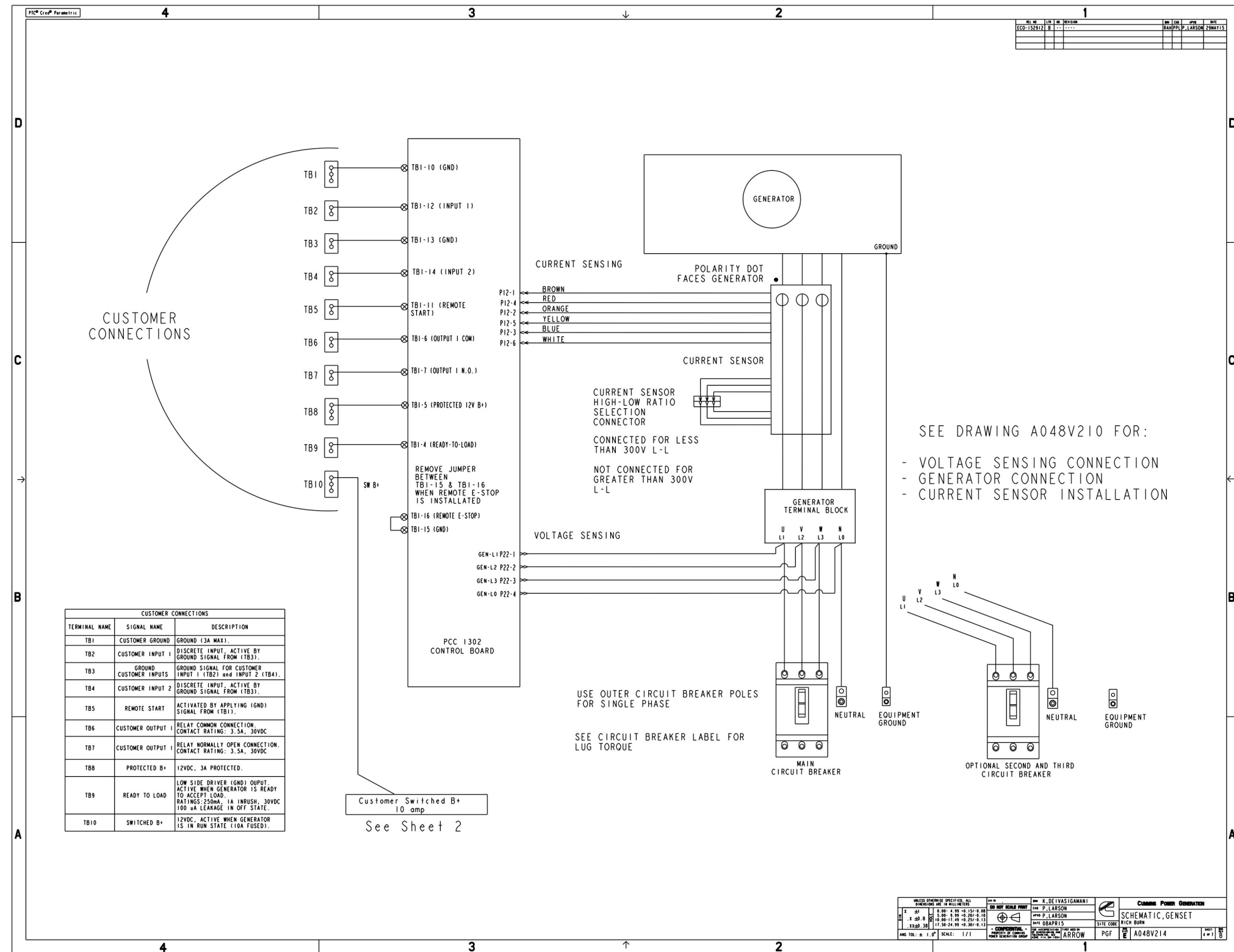

FIGURE 39. WIRING DIAGRAM FOR PCC 1302 (56 PIN ECM) (SHEET 4 OF 7)

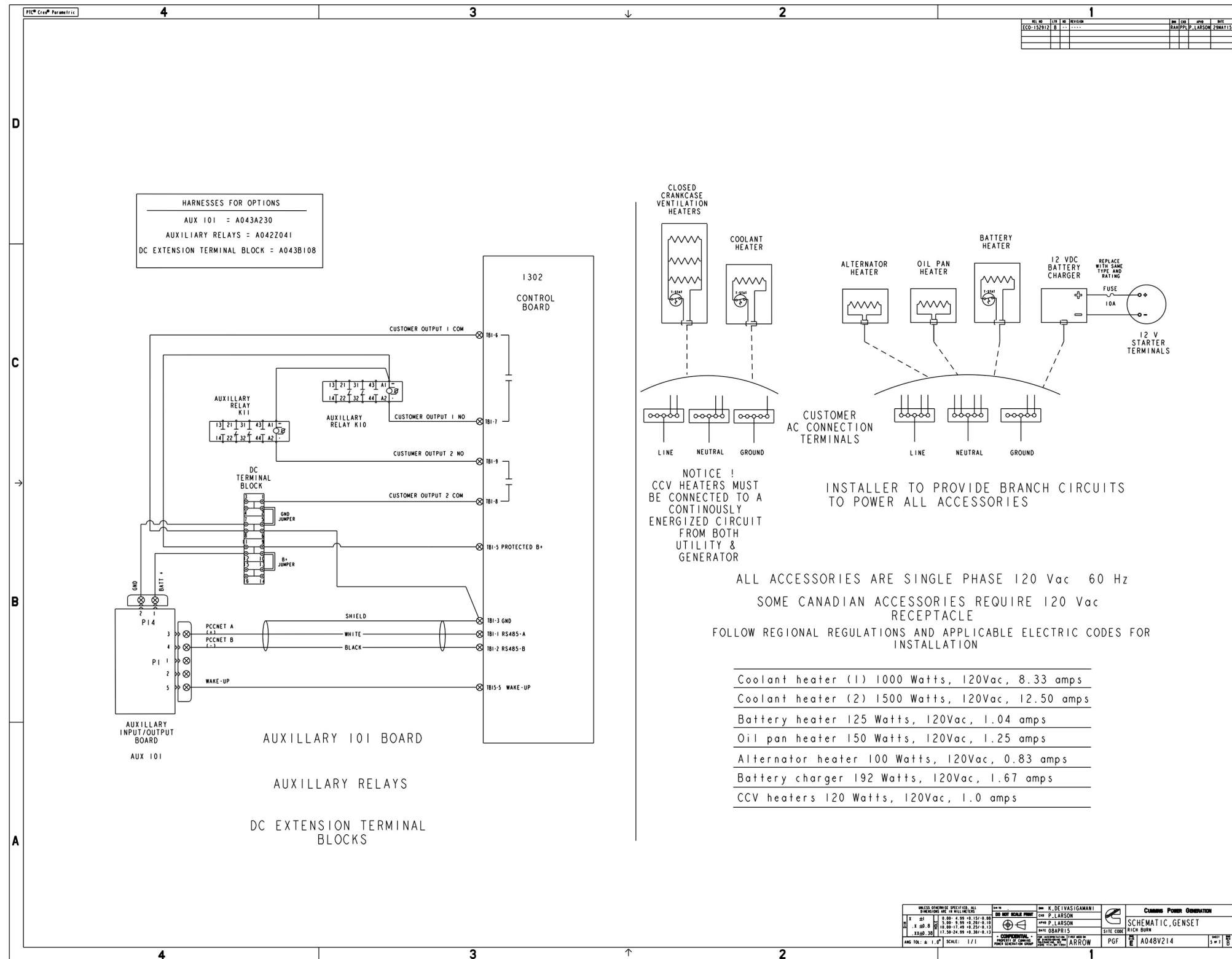

FIGURE 40. WIRING DIAGRAM FOR PCC 1302 (56 PIN ECM) (SHEET 5 OF 7)

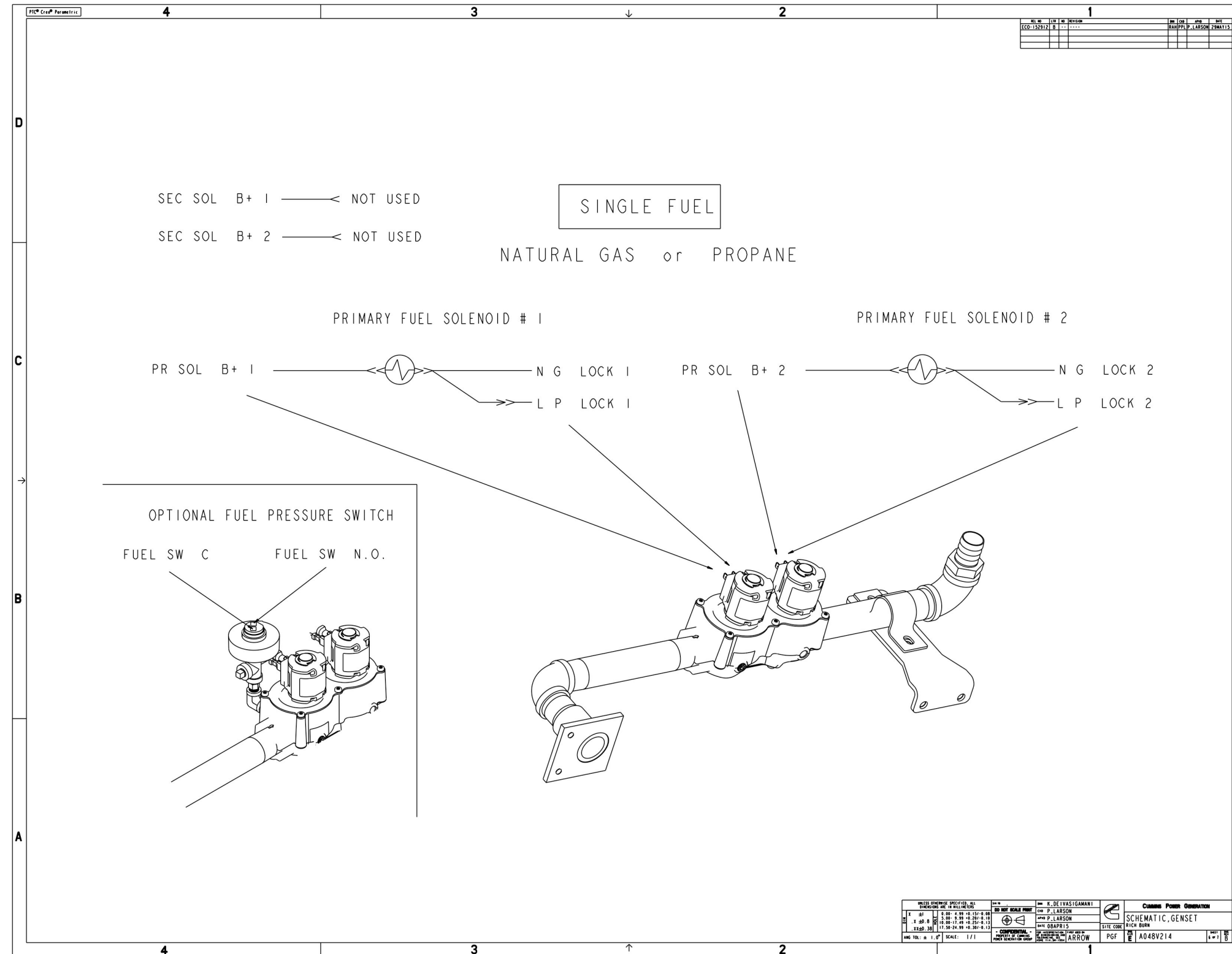

FIGURE 41. WIRING DIAGRAM FOR PCC 1302 (56 PIN ECM) (SHEET 6 OF 7)

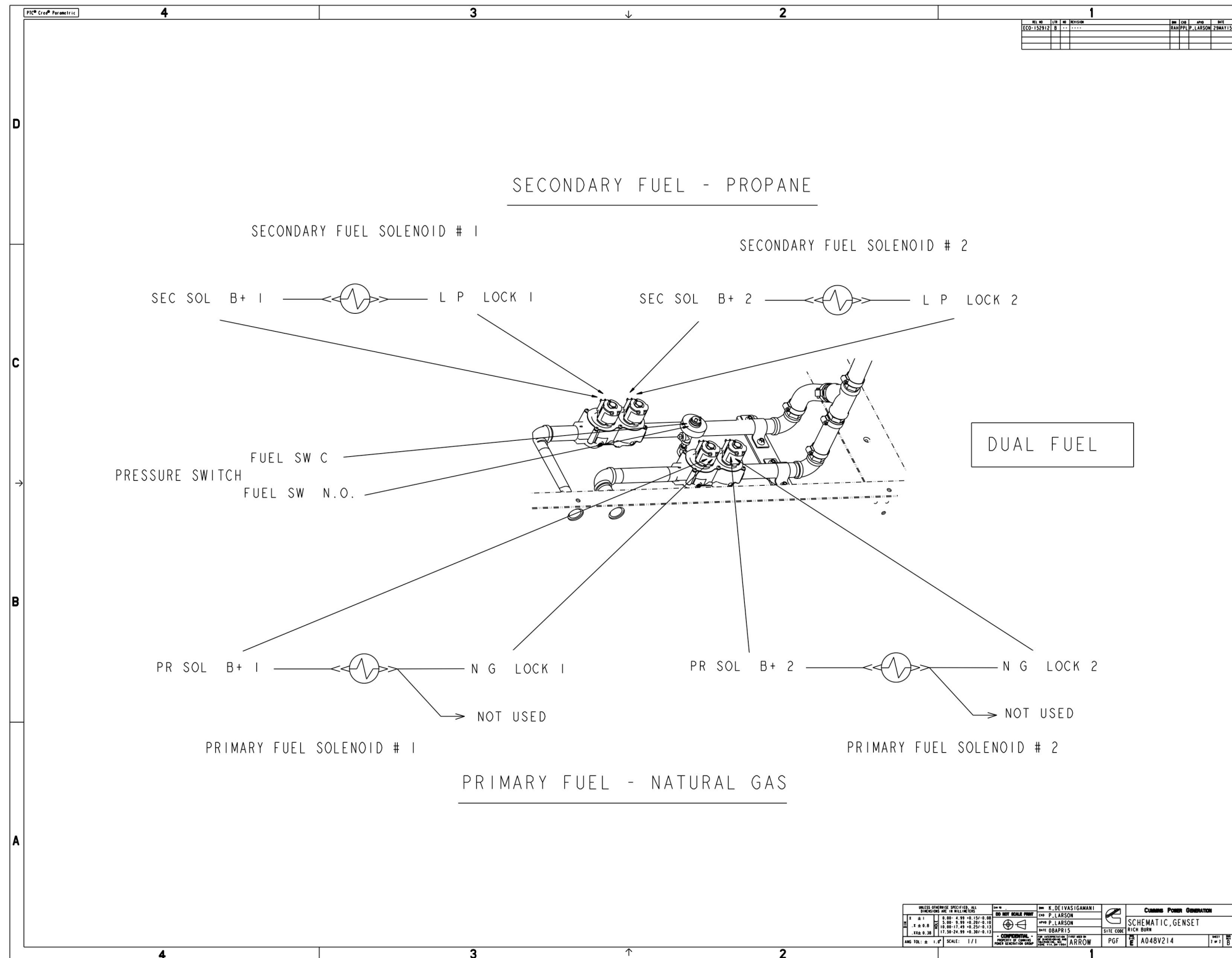

FIGURE 42. WIRING DIAGRAM FOR PCC 1302 (56 PIN ECM) (SHEET 7 OF 7)

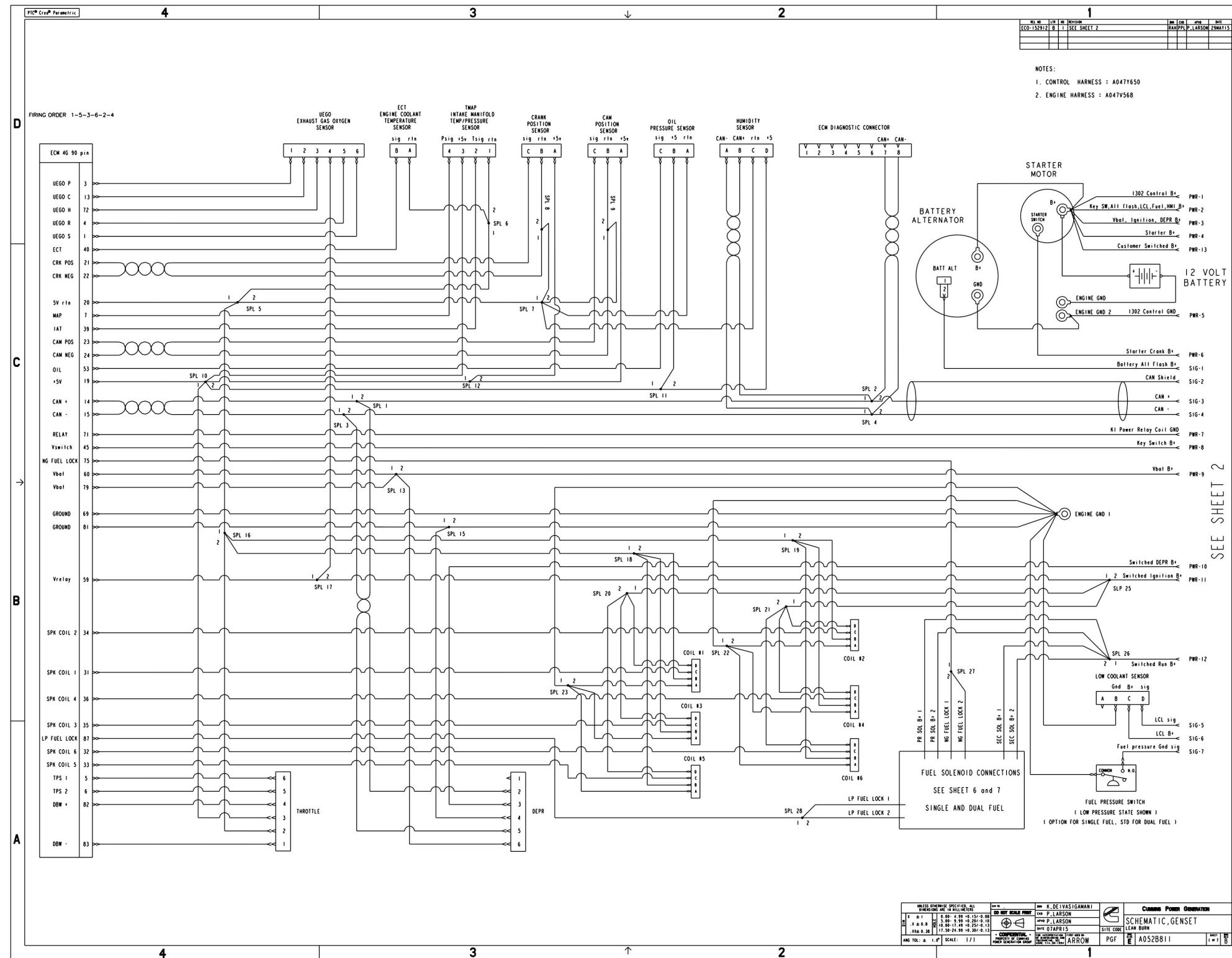

FIGURE 43. WIRING DIAGRAM FOR PCC 1302 (90 PIN ECM) (SHEET 1 OF 7)

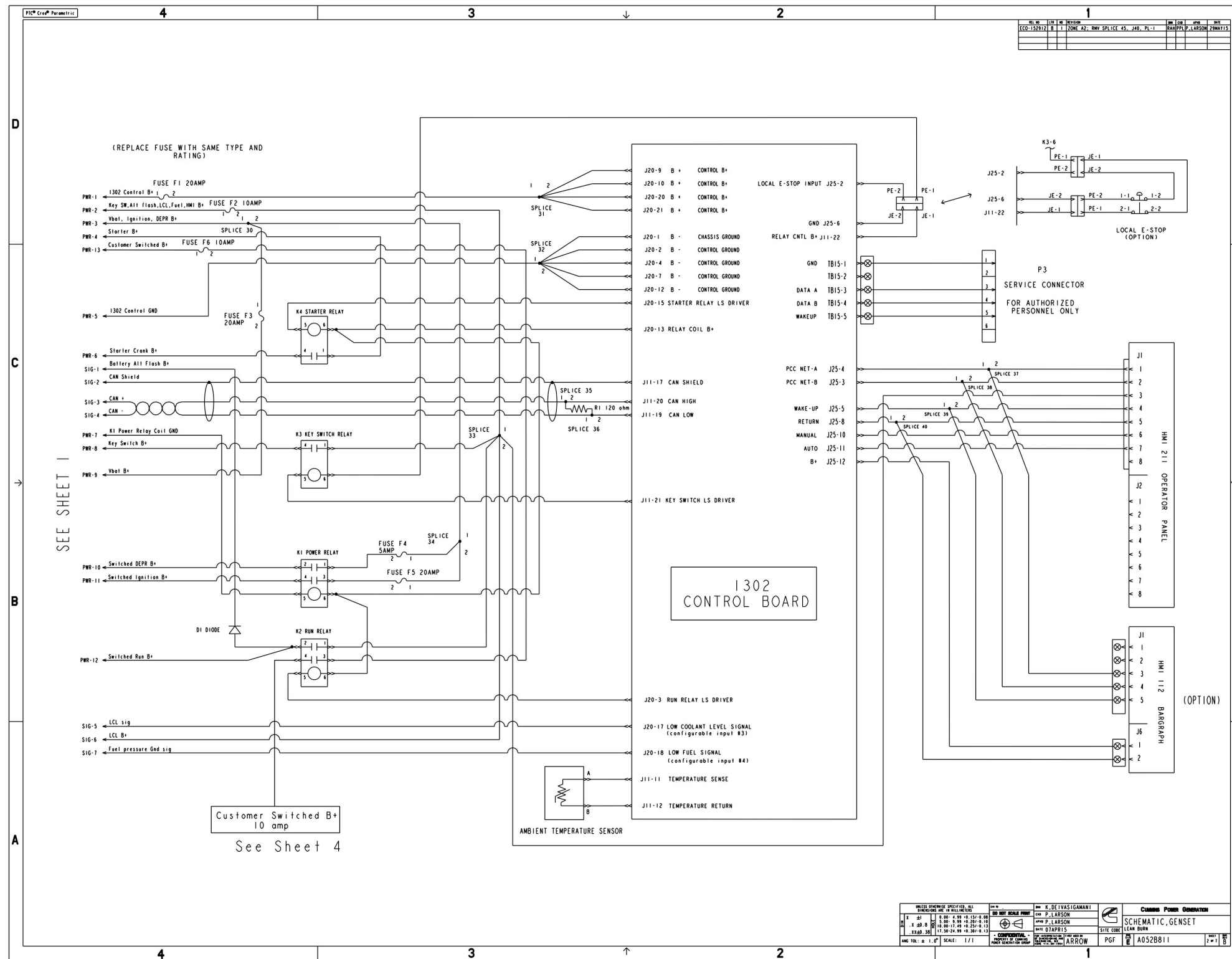

FIGURE 44. WIRING DIAGRAM FOR PCC 1302 (90 PIN ECM) (SHEET 2 OF 7)

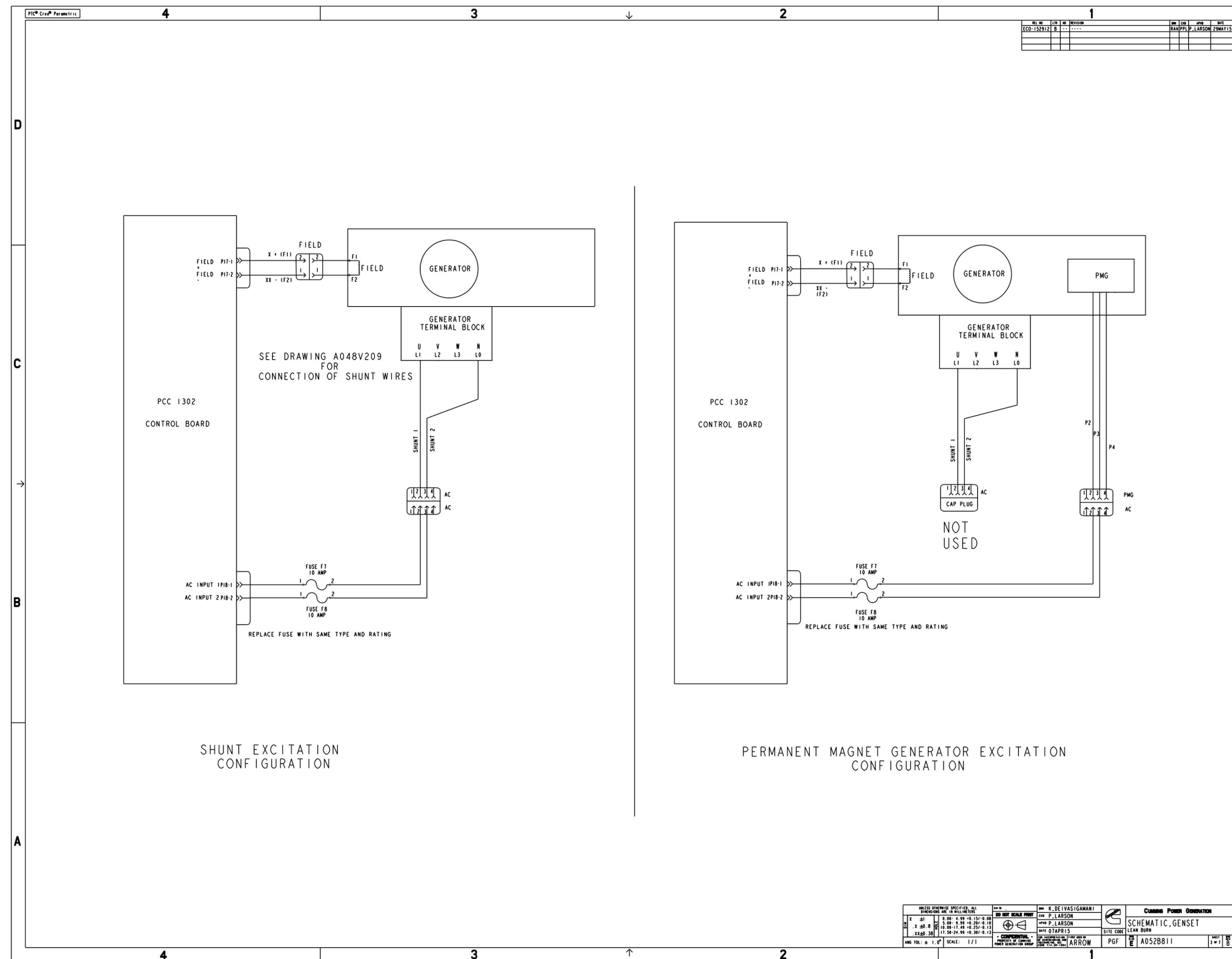

FIGURE 45. WIRING DIAGRAM FOR PCC 1302 (90 PIN ECM) (SHEET 3 OF 7)

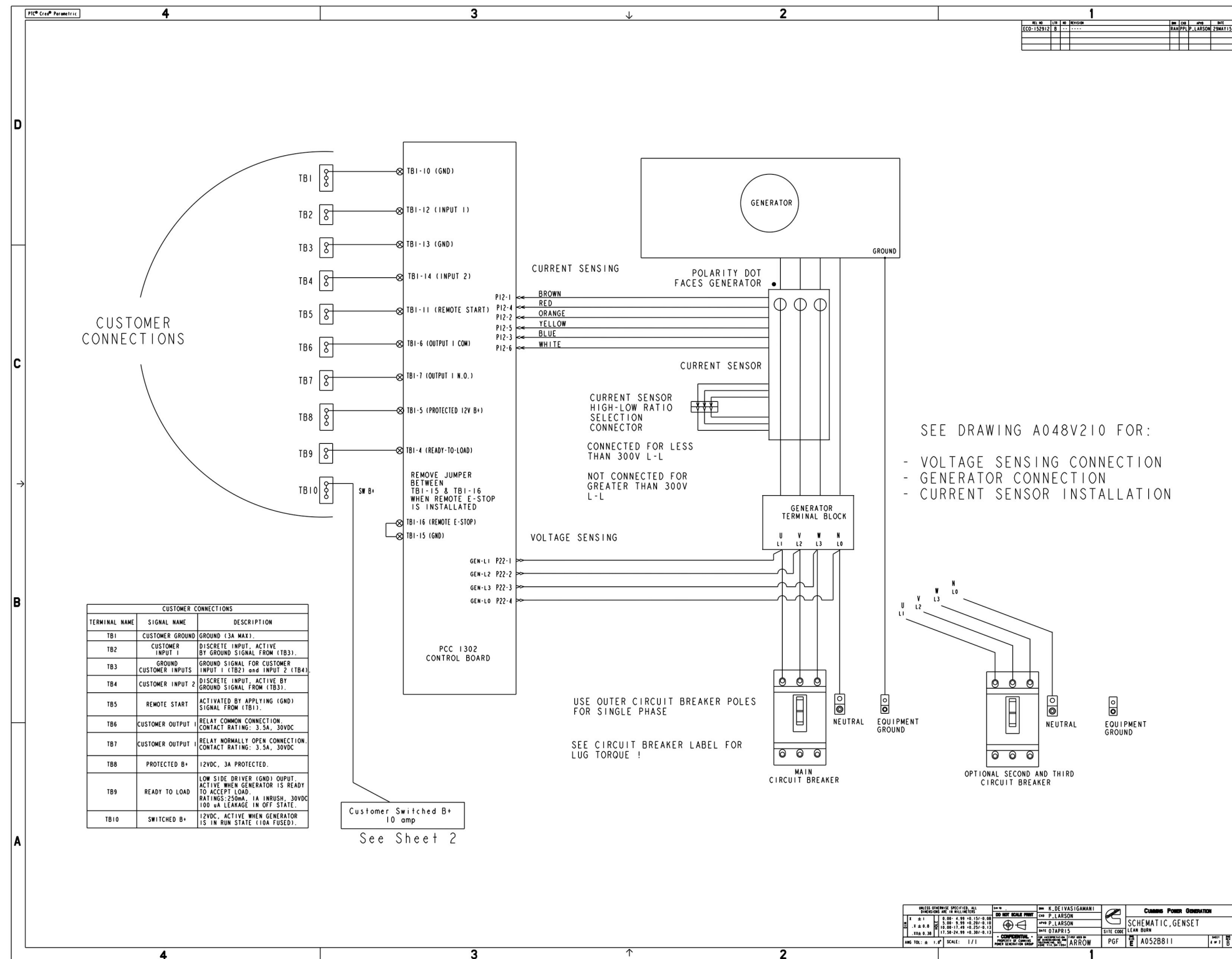

FIGURE 46. WIRING DIAGRAM FOR PCC 1302 (90 PIN ECM) (SHEET 4 OF 7)

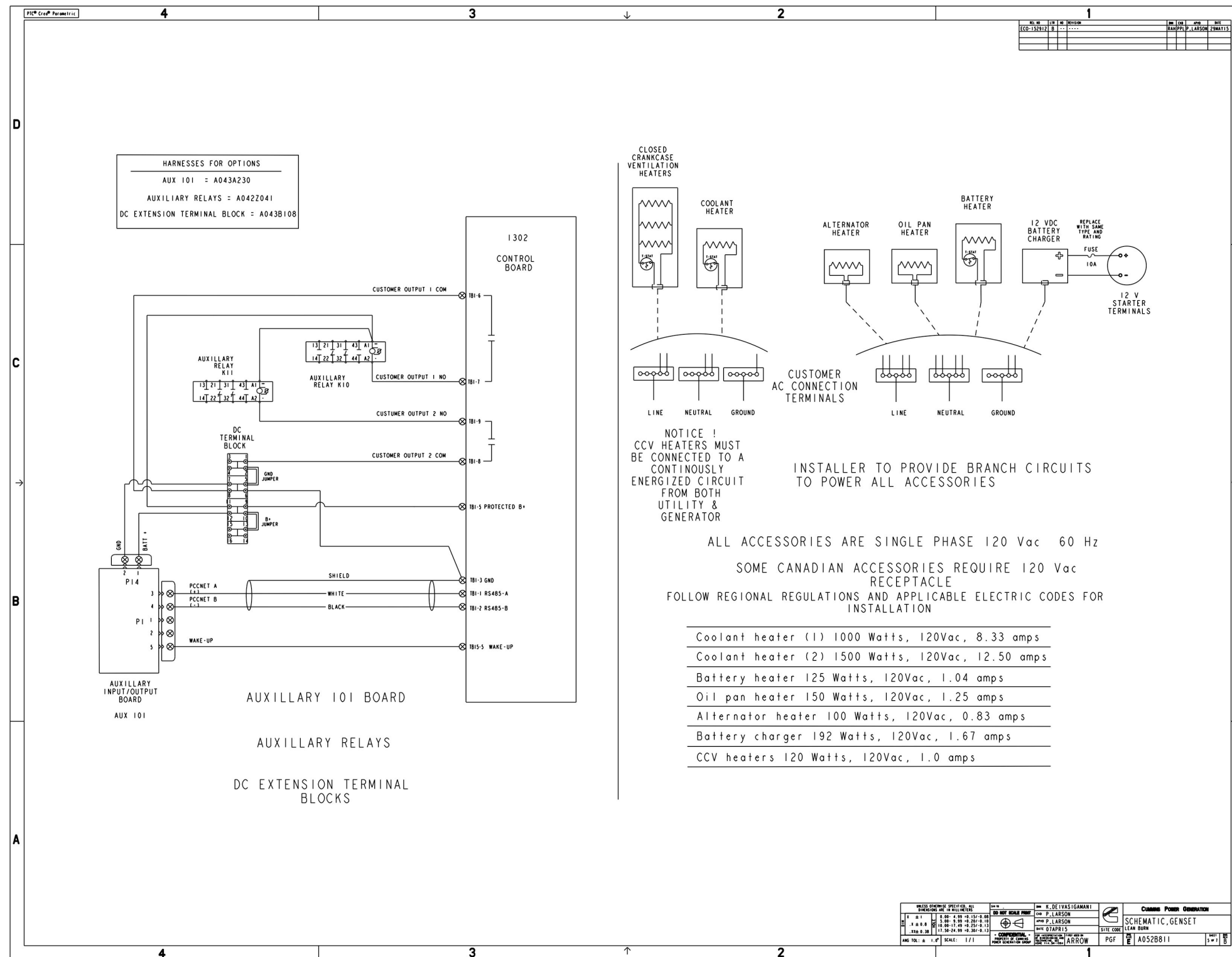

FIGURE 47. WIRING DIAGRAM FOR PCC 1302 (90 PIN ECM) (SHEET 5 OF 7)

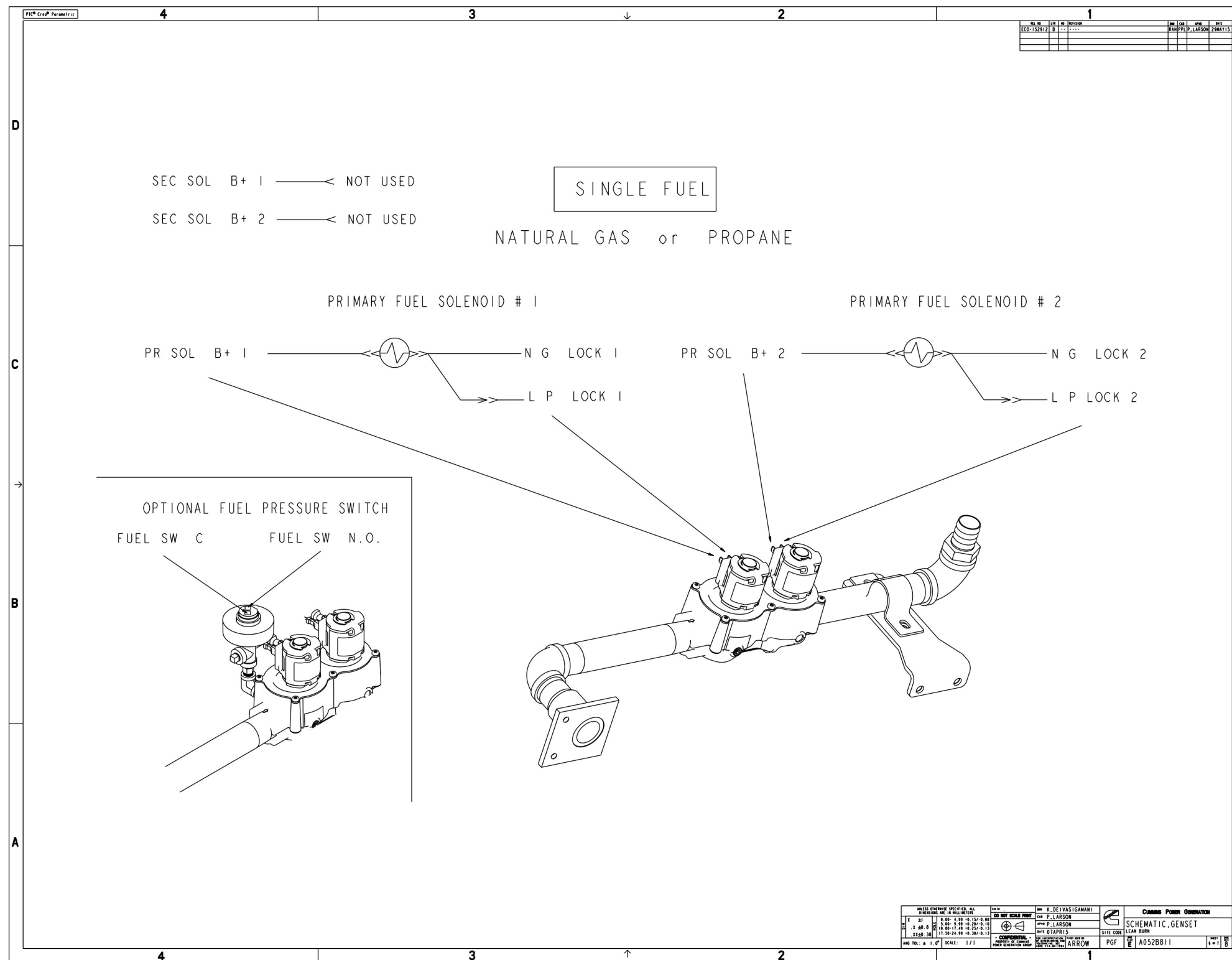

FIGURE 48. WIRING DIAGRAM FOR PCC 1302 (90 PIN ECM) (SHEET 6 OF 7)

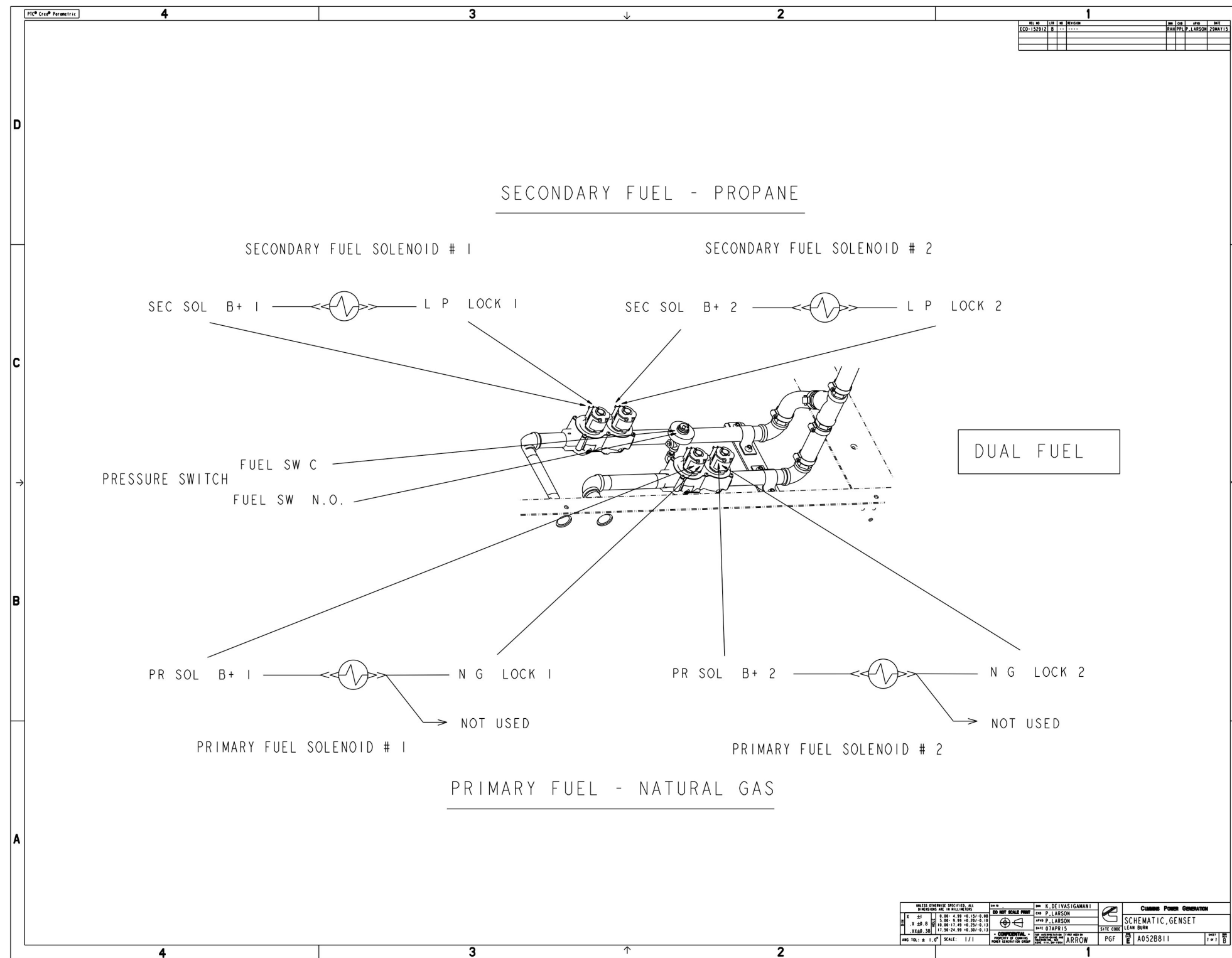

FIGURE 49. WIRING DIAGRAM FOR PCC 1302 (90 PIN ECM) (SHEET 7 OF 7)

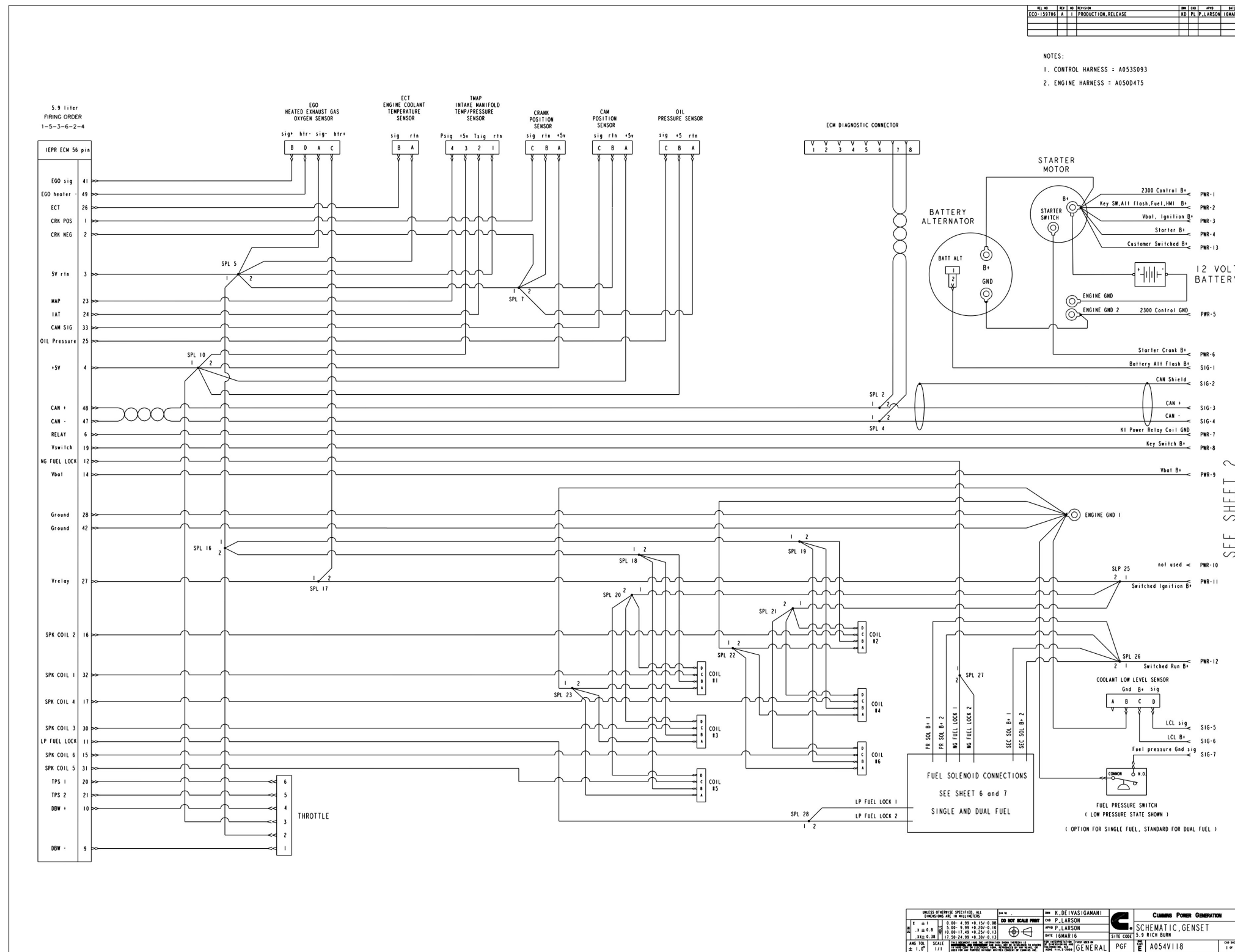

FIGURE 50. WIRING DIAGRAM FOR PCC 2300 (56 PIN ECM) (SHEET 1 OF 7)

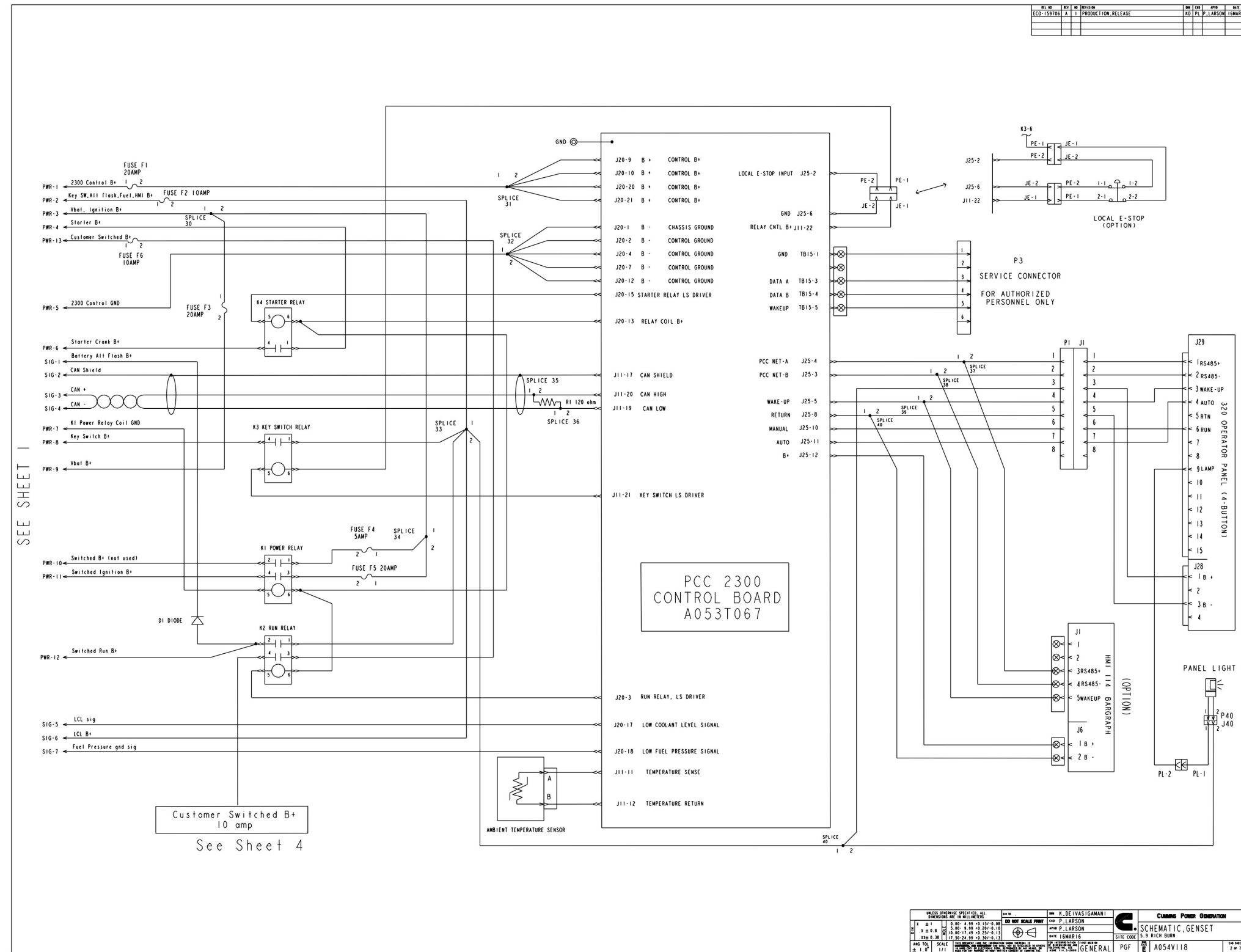

FIGURE 51. WIRING DIAGRAM FOR PCC 2300 (56 PIN ECM) (SHEET 2 OF 7)

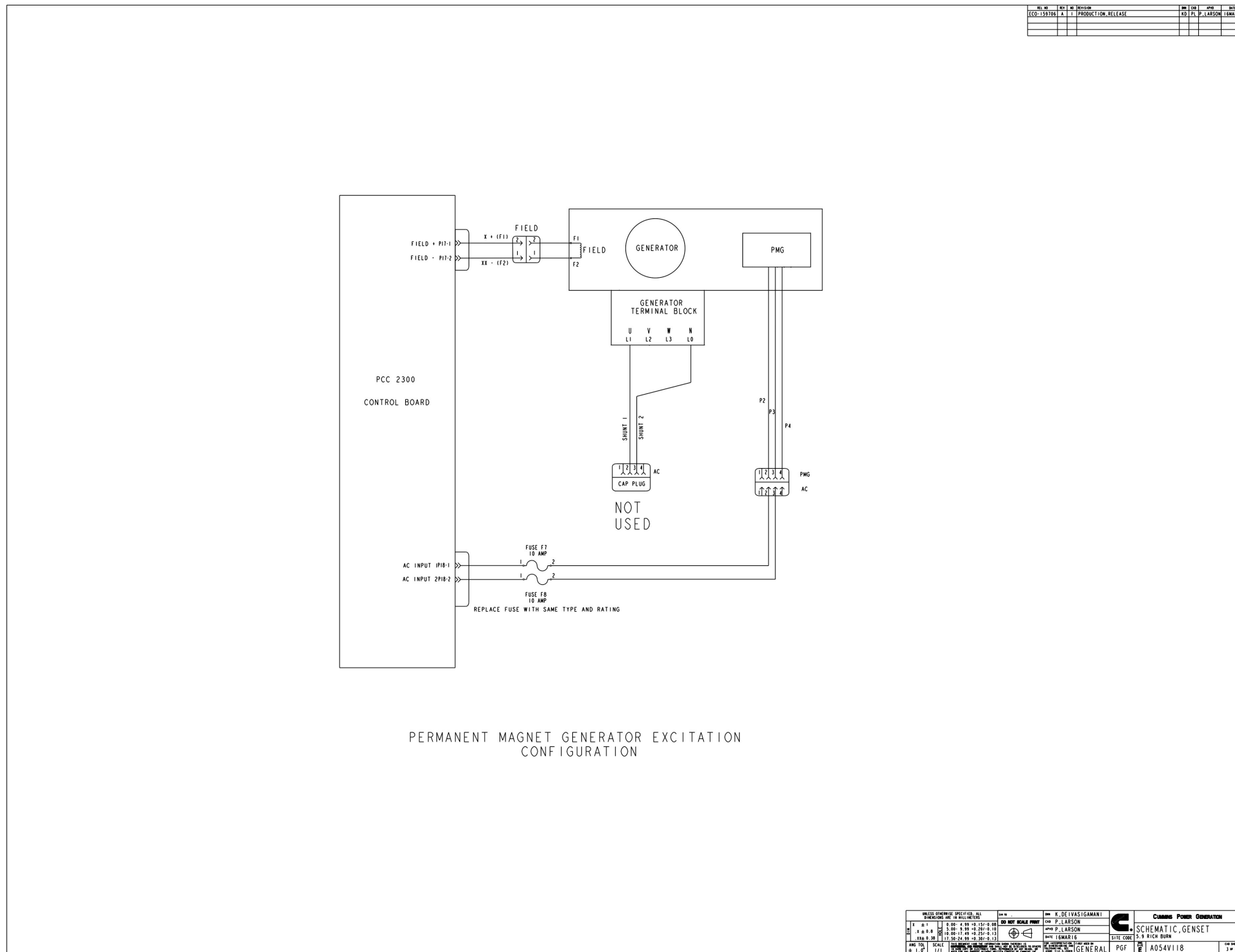
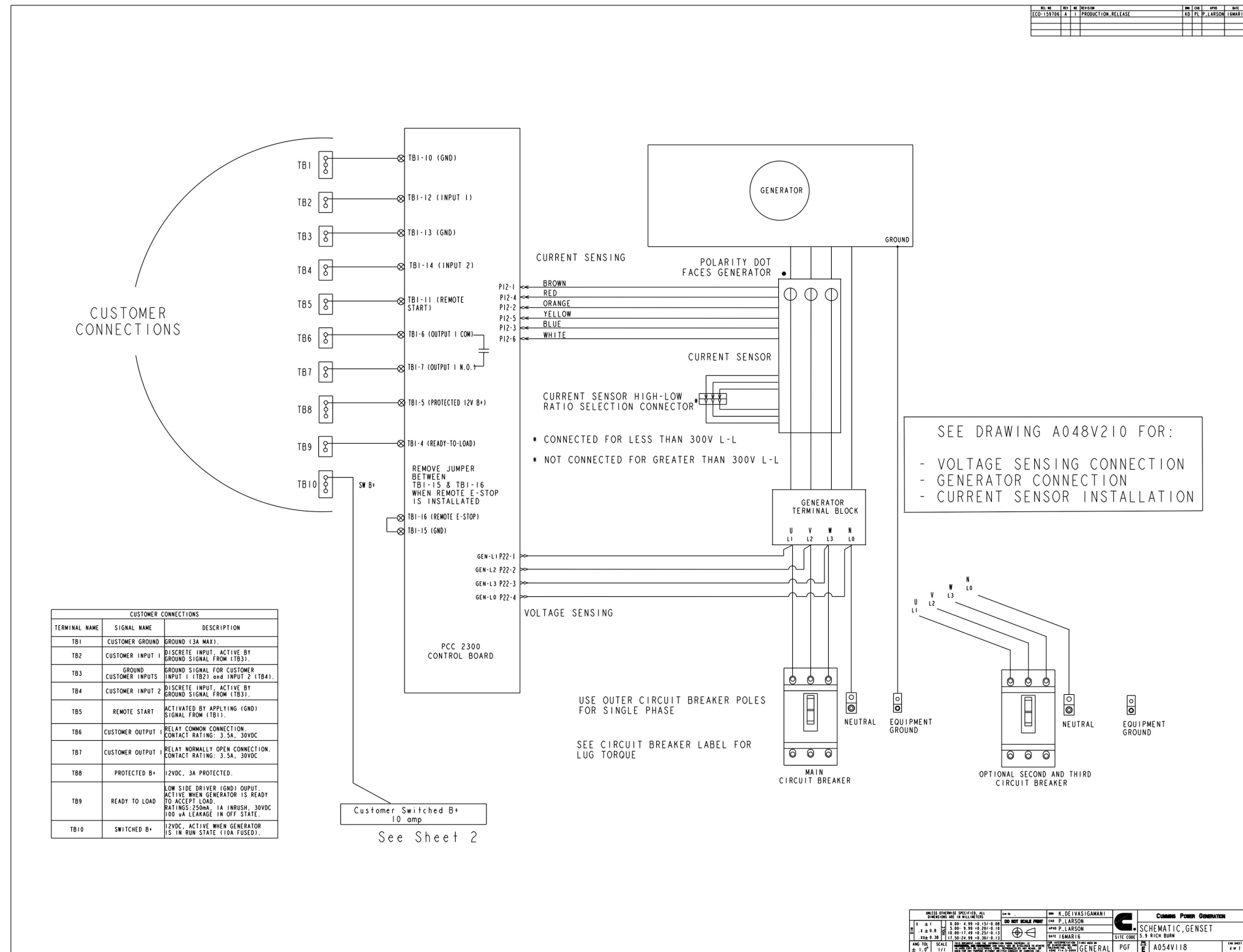

FIGURE 52. WIRING DIAGRAM FOR PCC 2300 (56 PIN ECM) (SHEET 3 OF 7)



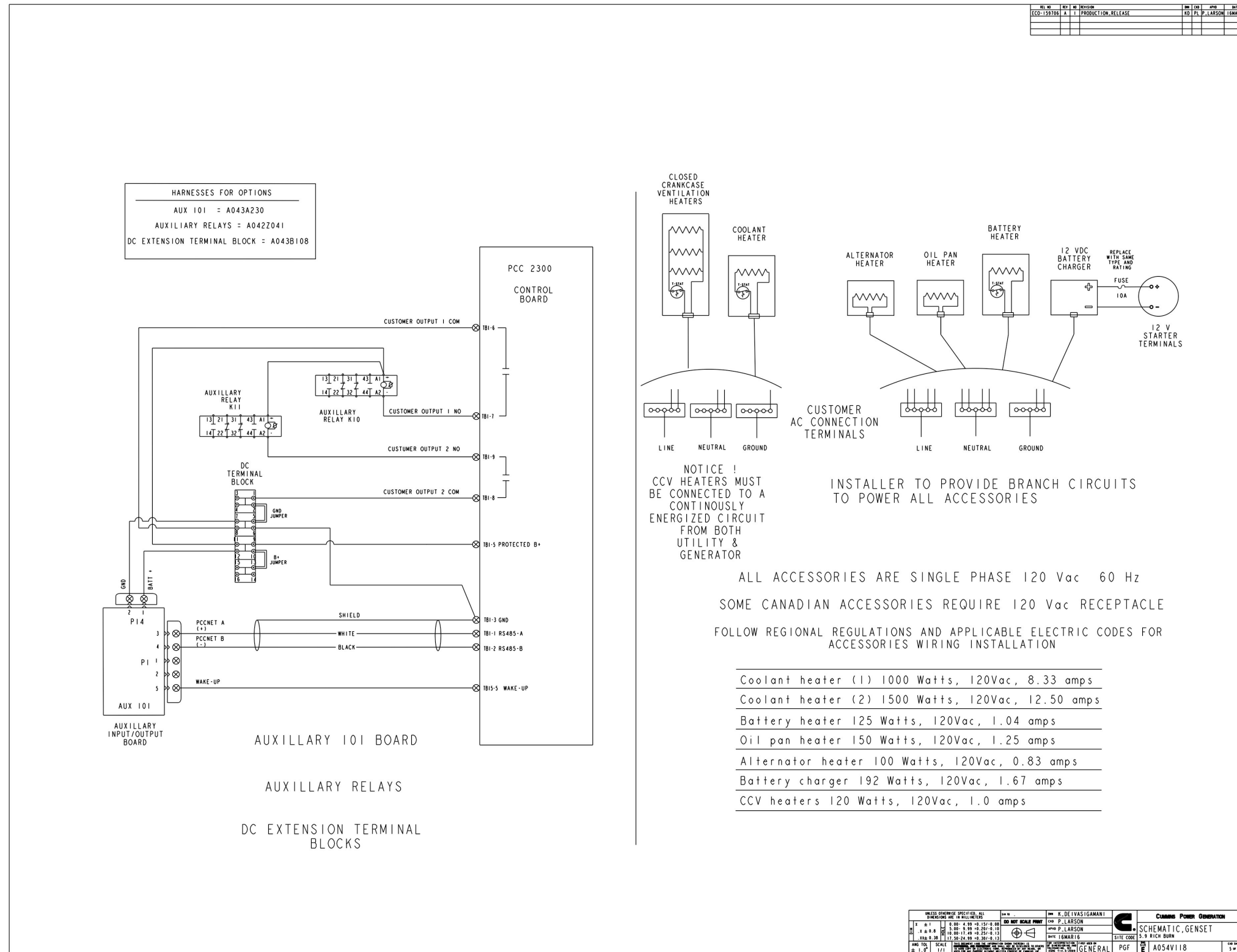

FIGURE 54. WIRING DIAGRAM FOR PCC 2300 (56 PIN ECM) (SHEET 5 OF 7)

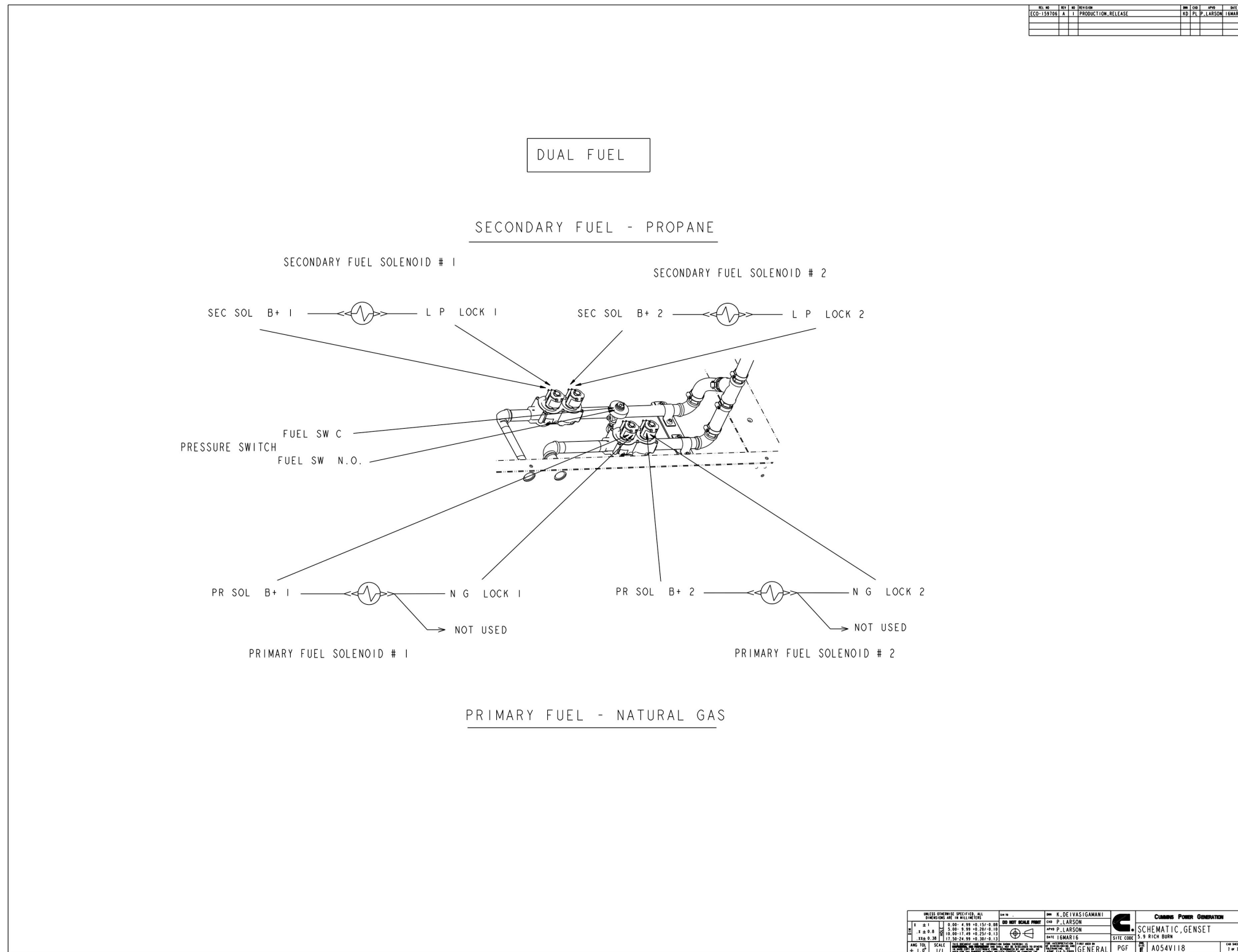

FIGURE 56. WIRING DIAGRAM FOR PCC 2300 (56 PIN ECM) (SHEET 7 OF 7)

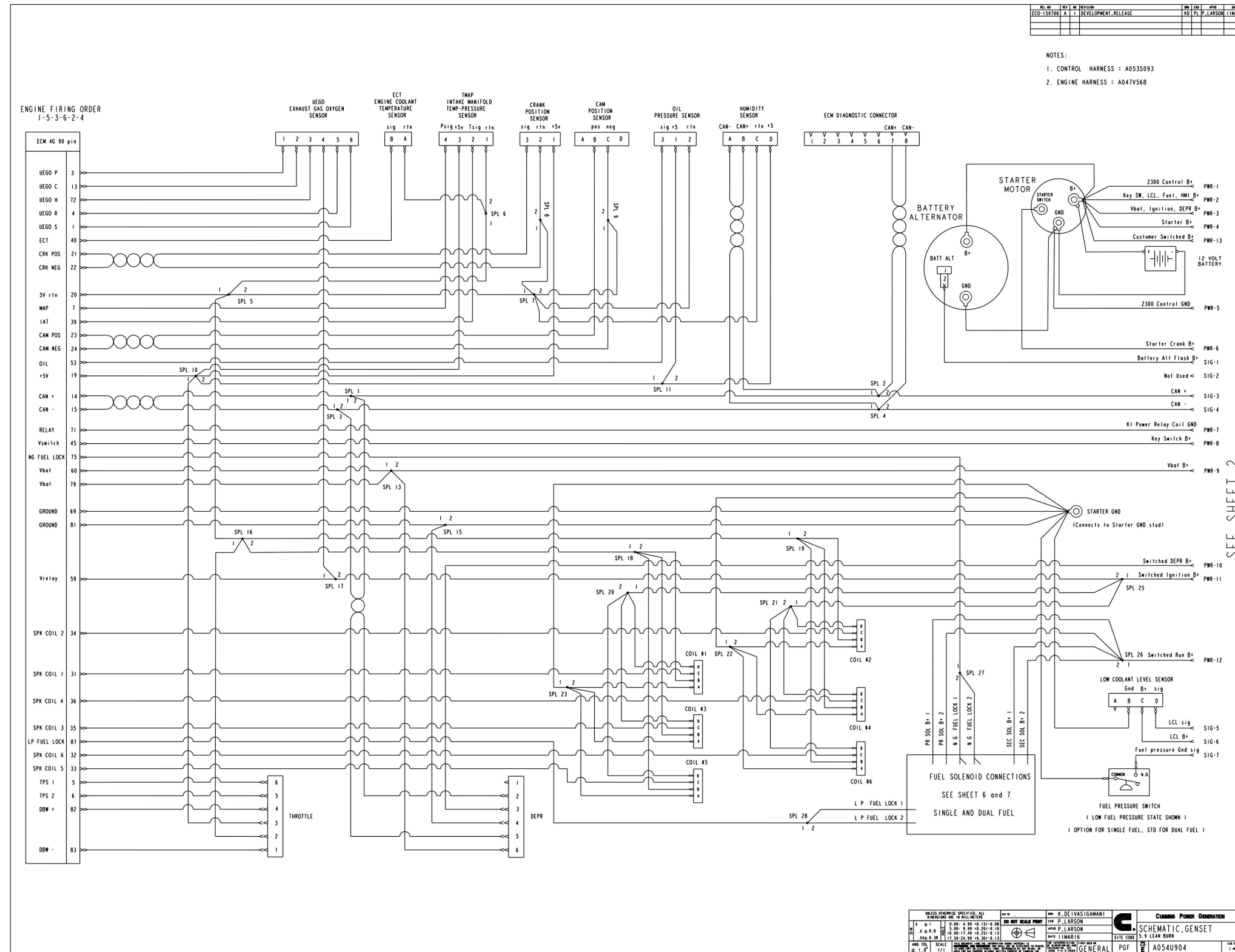

FIGURE 57. WIRING DIAGRAM FOR PCC 2300 (90 PIN ECM) (SHEET 1 OF 7)

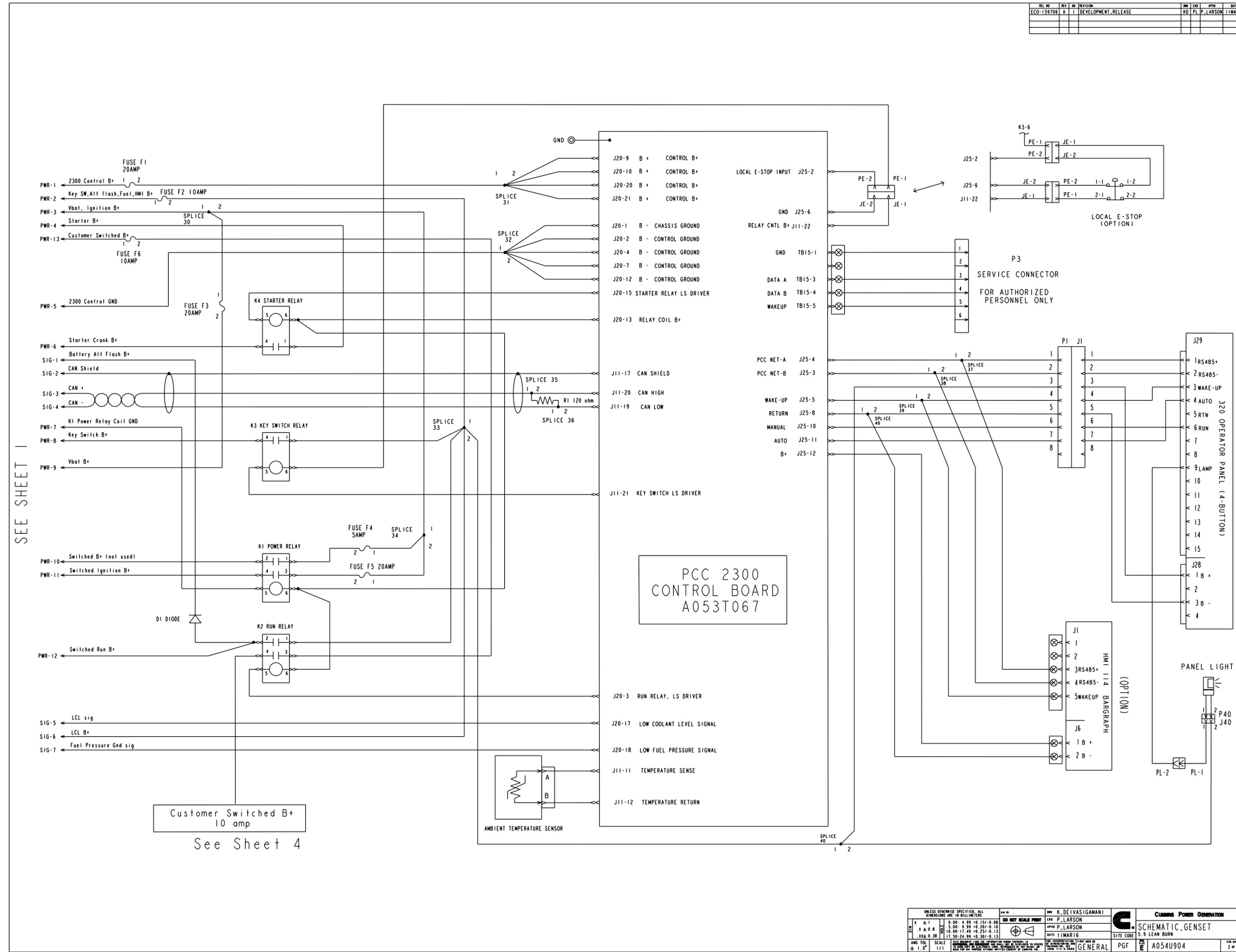

FIGURE 58. WIRING DIAGRAM FOR PCC 2300 (90 PIN ECM) (SHEET 2 OF 7)

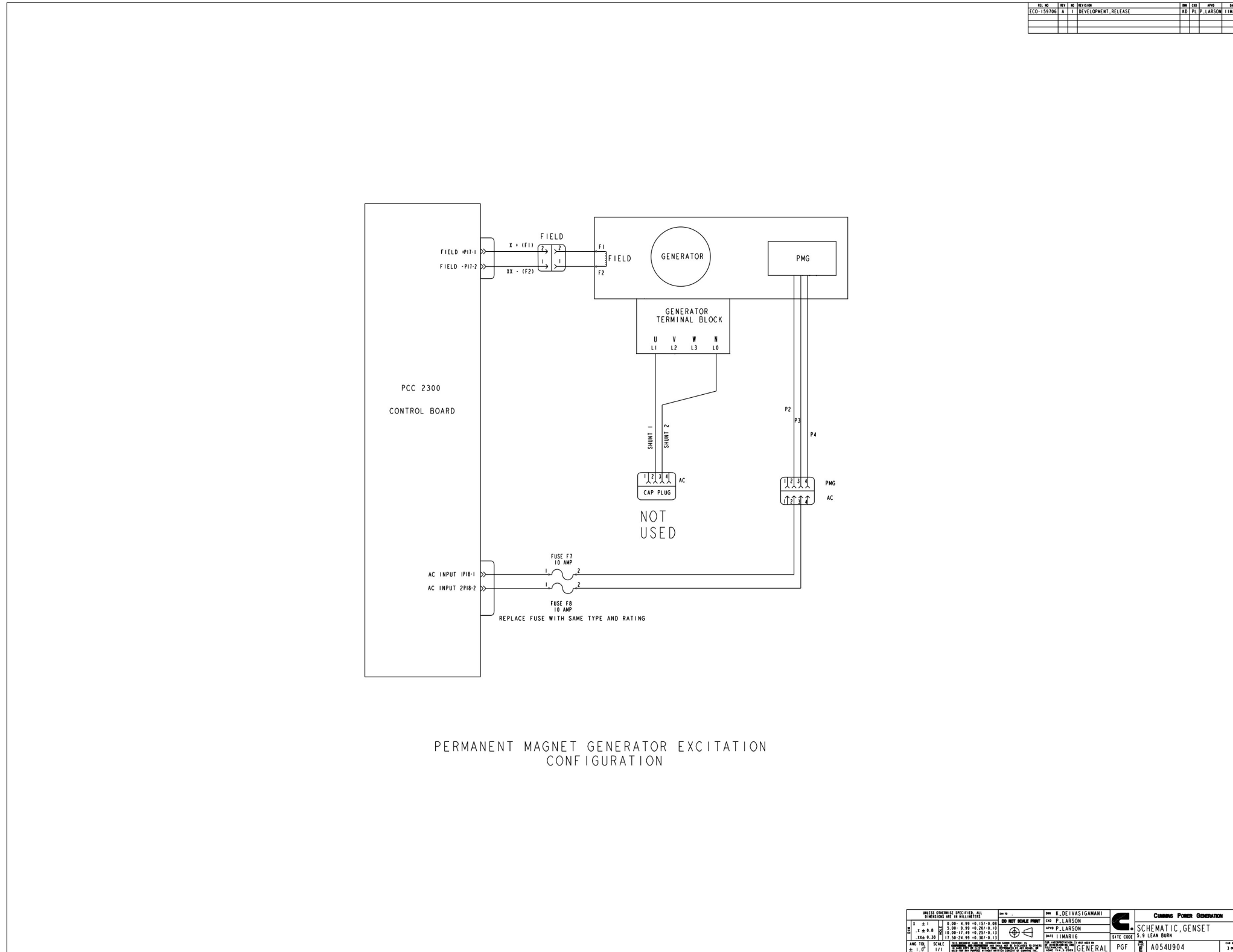

FIGURE 59. WIRING DIAGRAM FOR PCC 2300 (90 PIN ECM) (SHEET 3 OF 7)

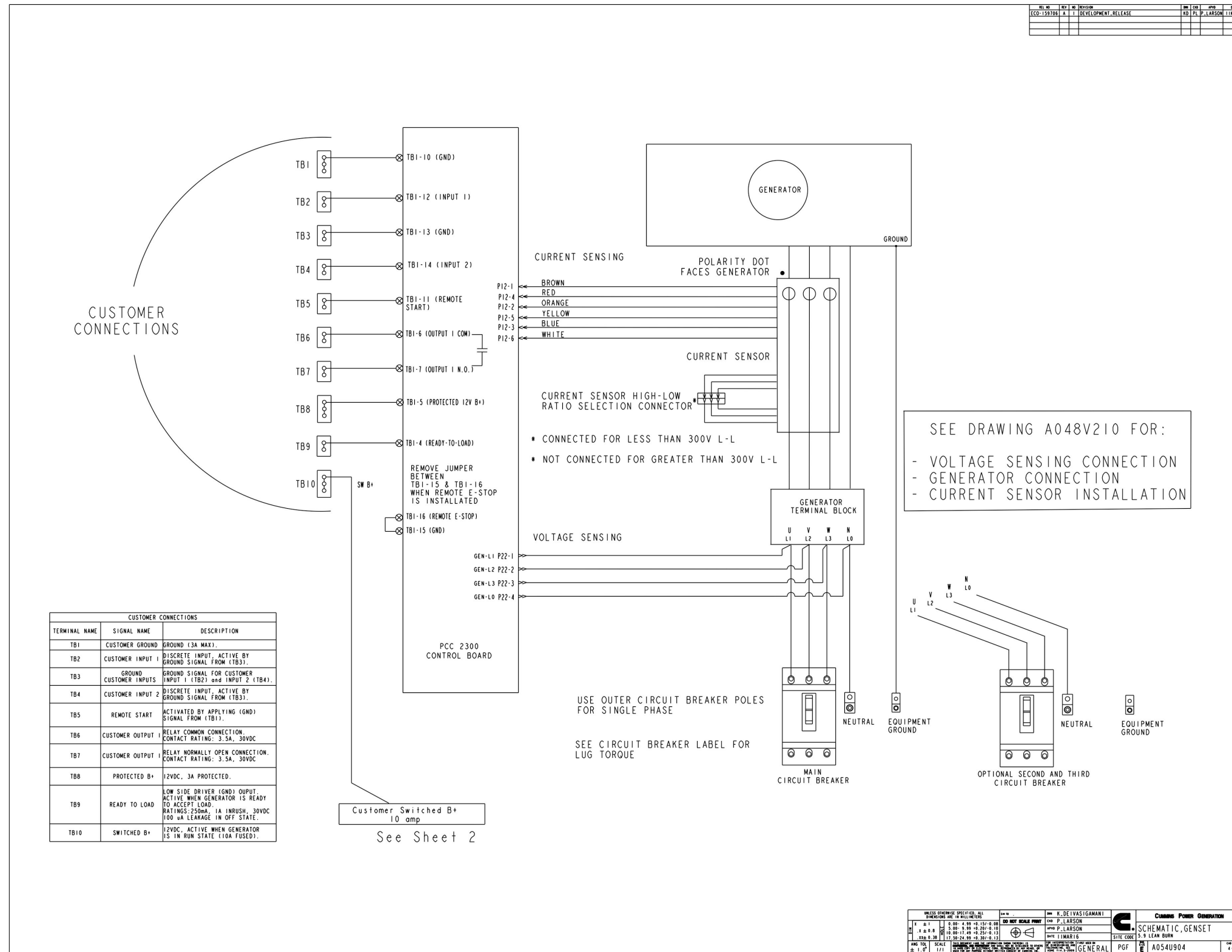
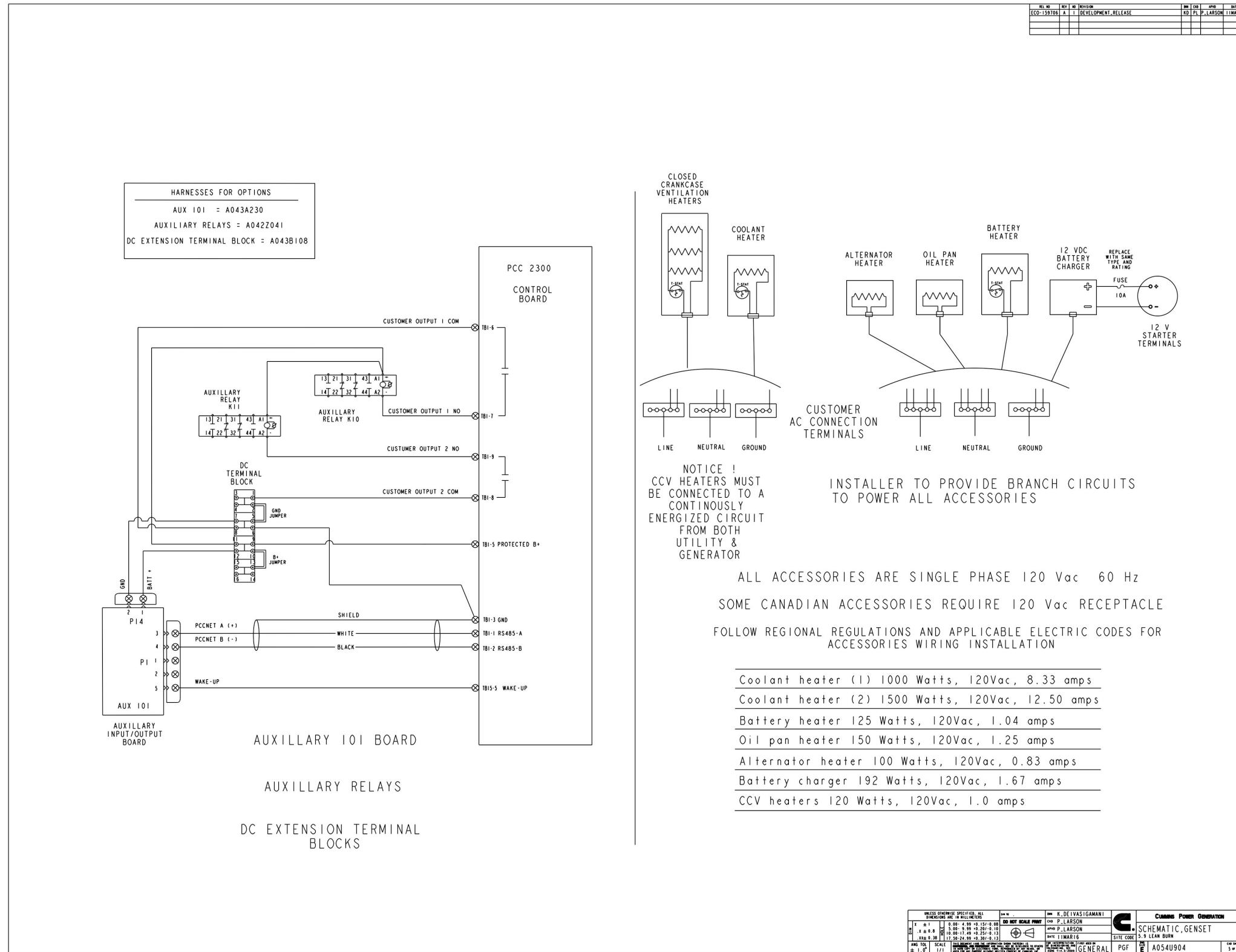

FIGURE 60. WIRING DIAGRAM FOR PCC 2300 (90 PIN ECM) (SHEET 4 OF 7)



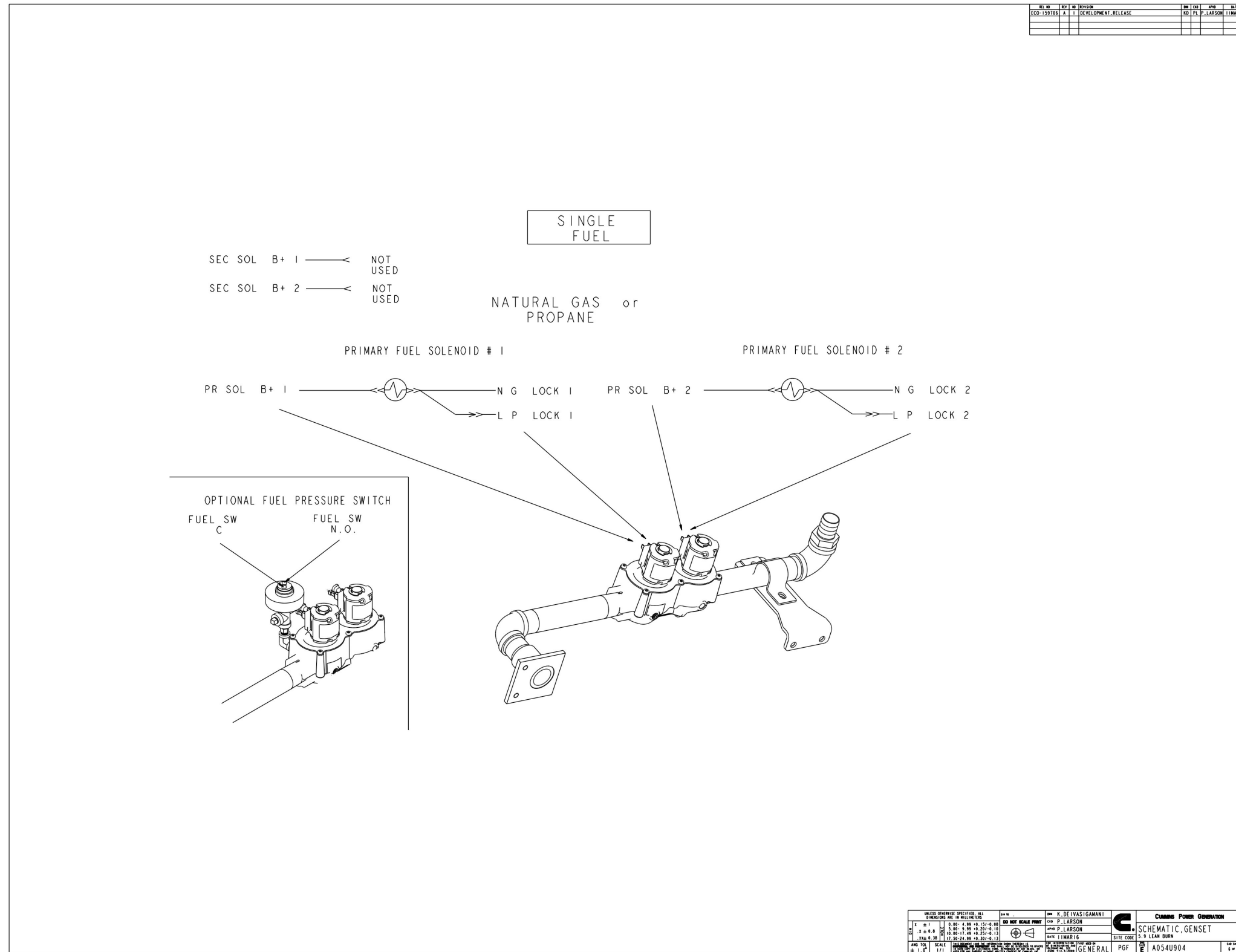

FIGURE 62. WIRING DIAGRAM FOR PCC 2300 (90 PIN ECM) (SHEET 6 OF 7)

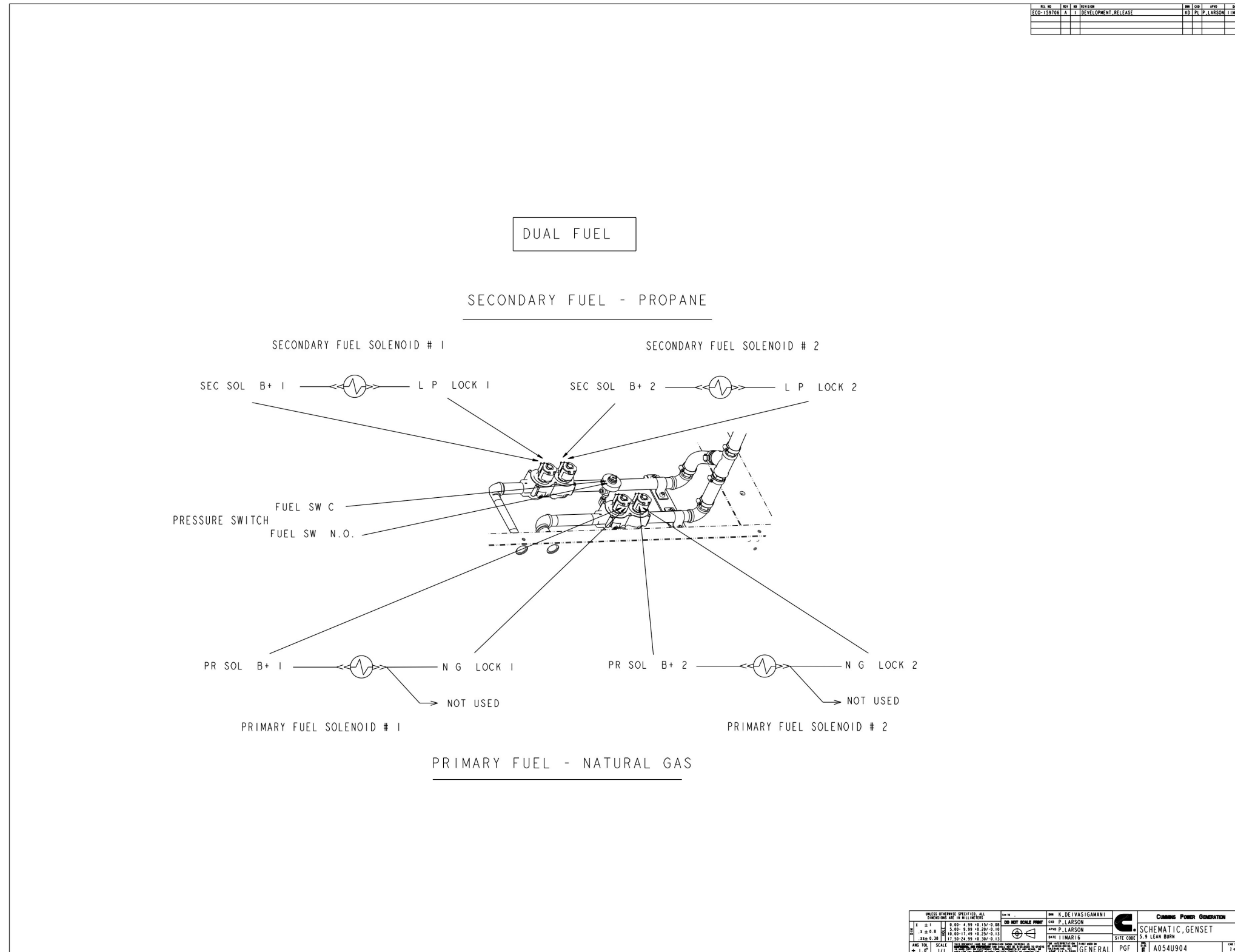

FIGURE 63. WIRING DIAGRAM FOR PCC 2300 (90 PIN ECM) (SHEET 7 OF 7)

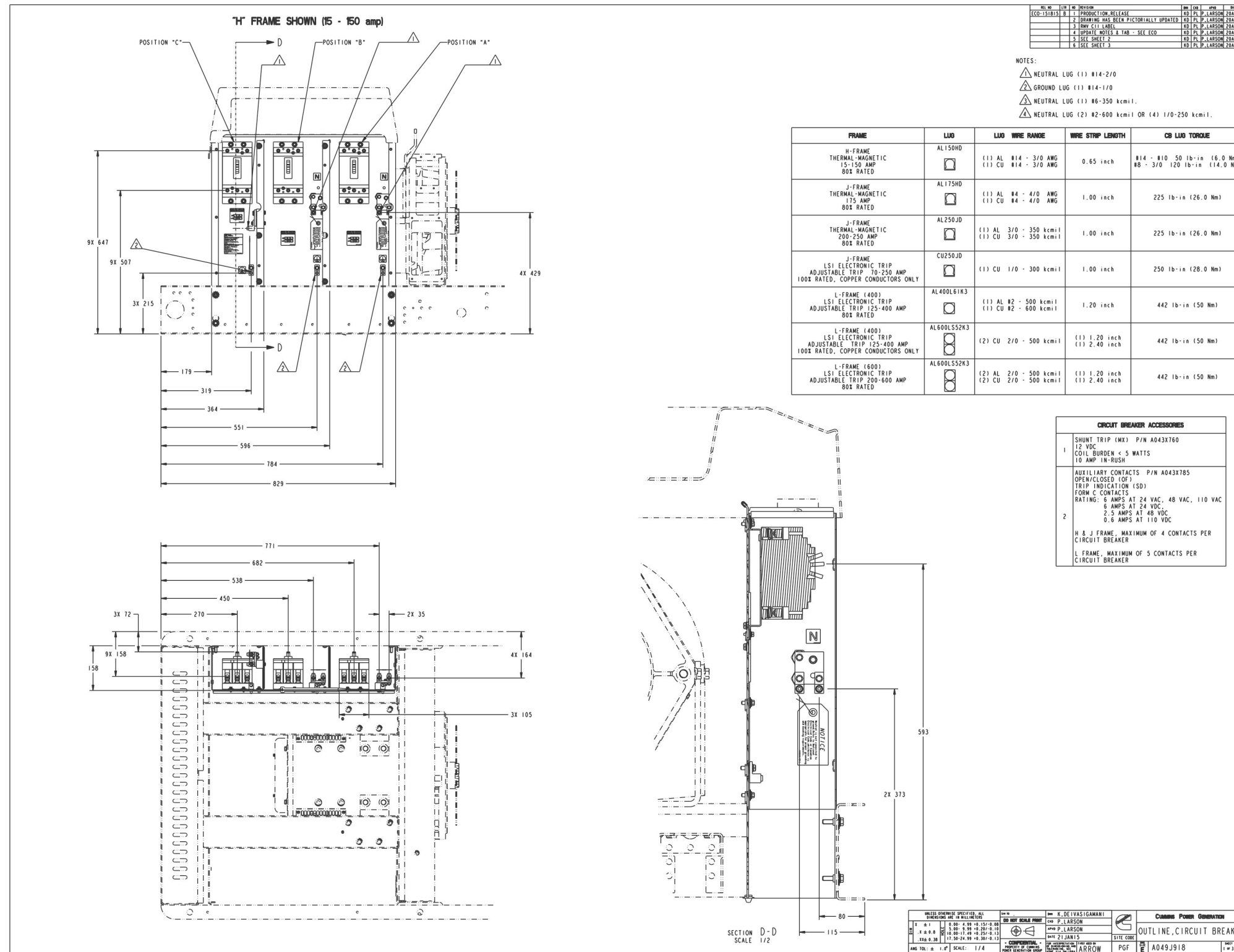

FIGURE 64. CIRCUIT BREAKER OUTLINE (SHEET 1 OF 3)

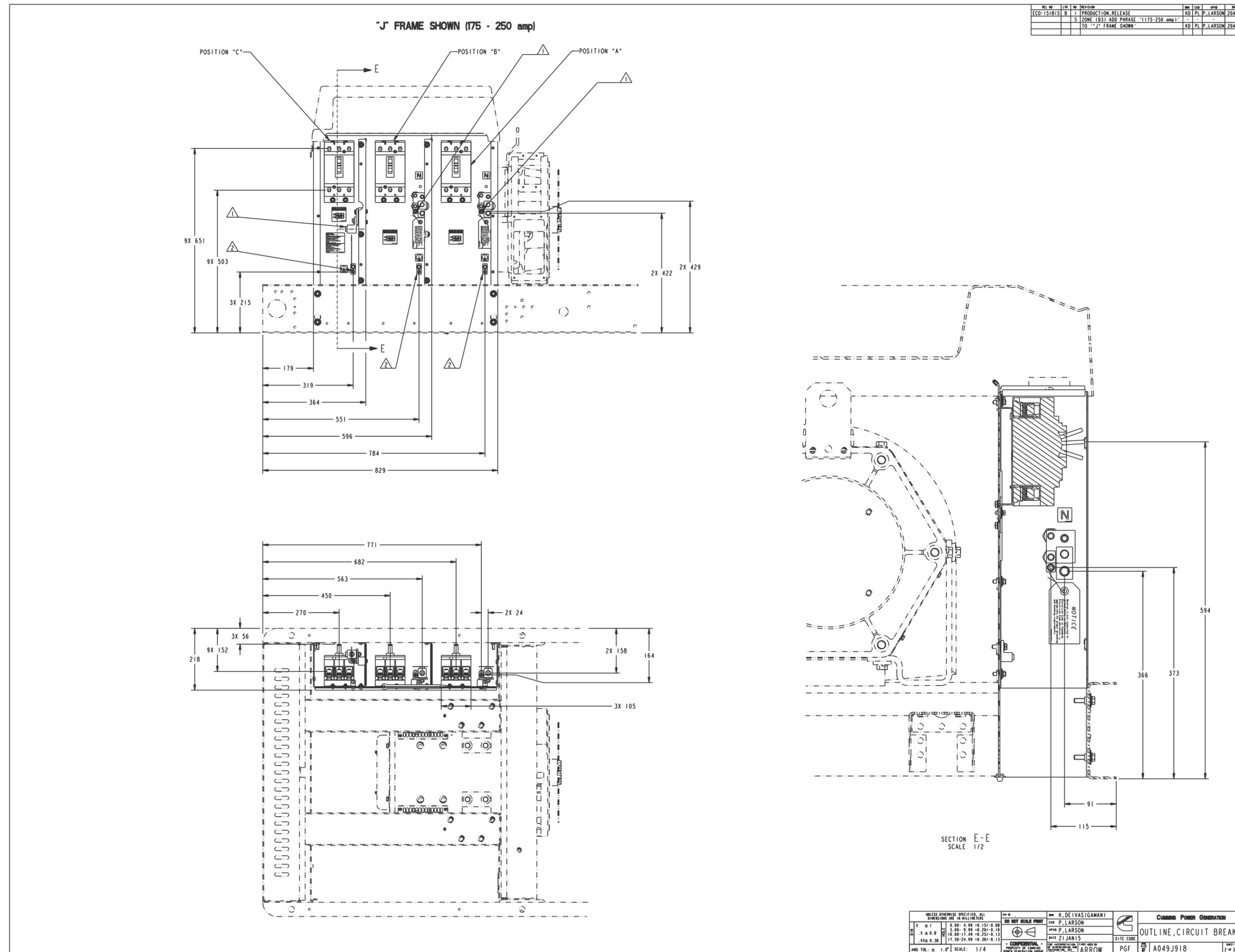

FIGURE 65. CIRCUIT BREAKER OUTLINE (SHEET 2 OF 3)

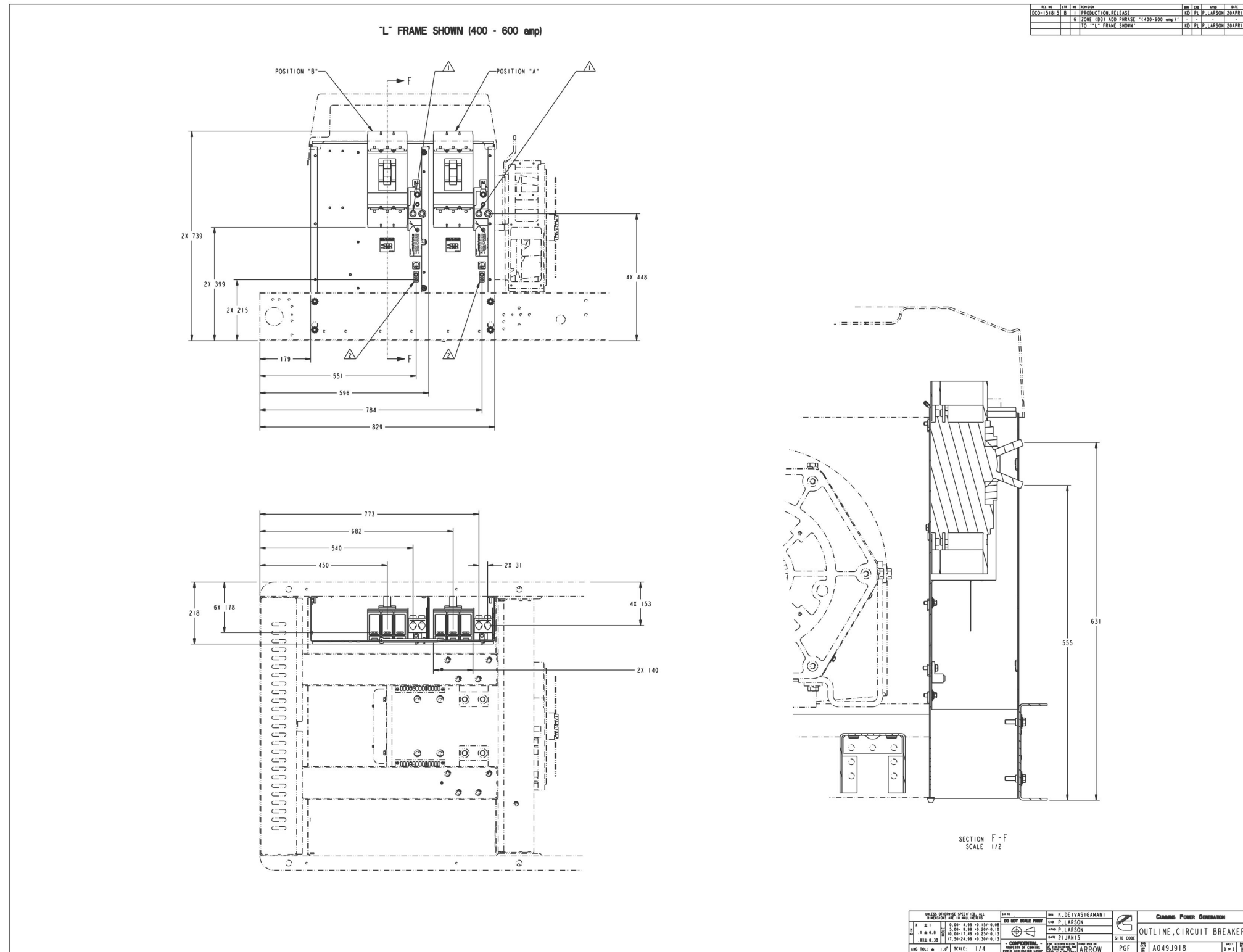

FIGURE 66. CIRCUIT BREAKER OUTLINE (SHEET 3 OF 3)

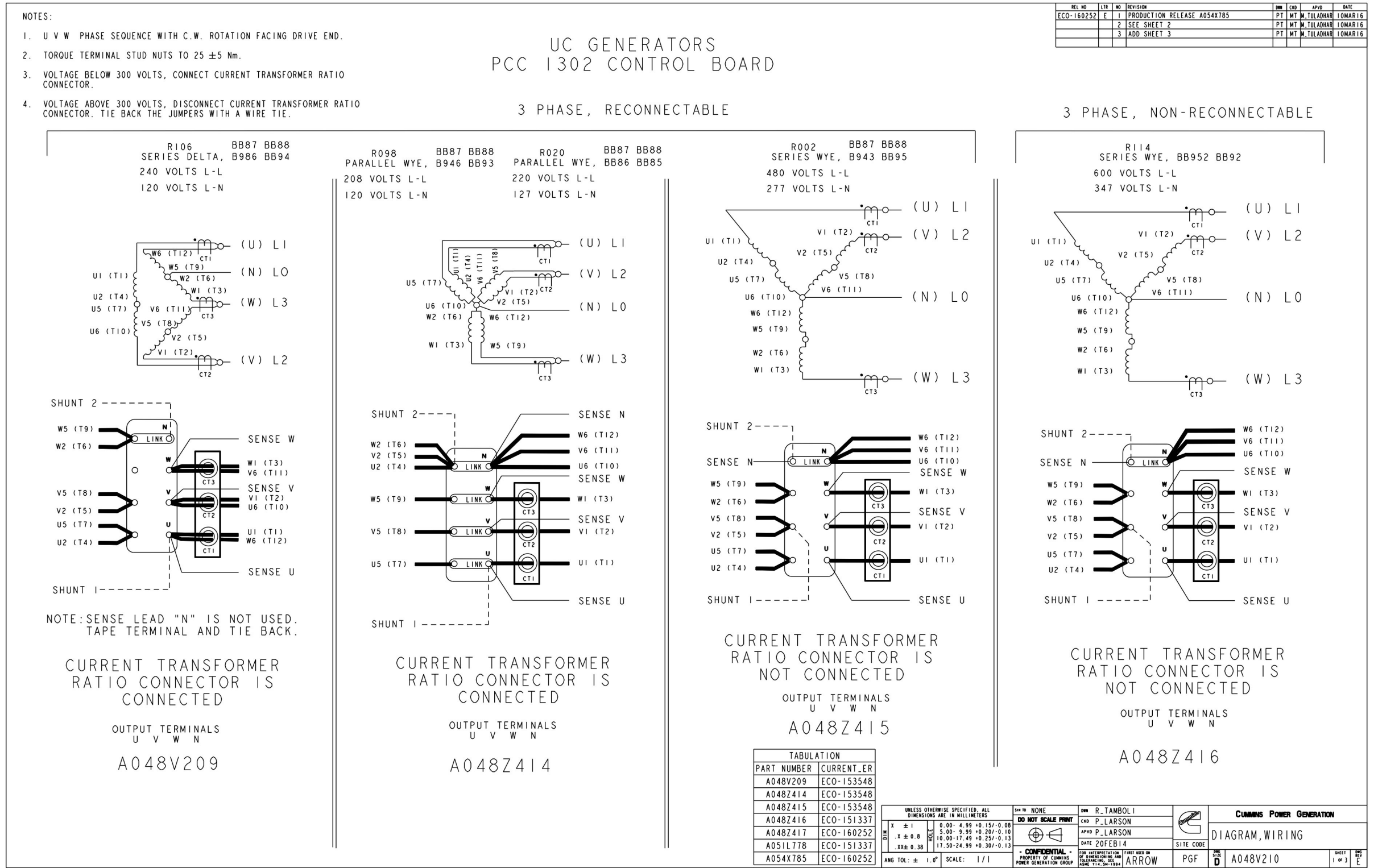

FIGURE 67. PCC 1302/2300 (SHEET 1 OF 3)

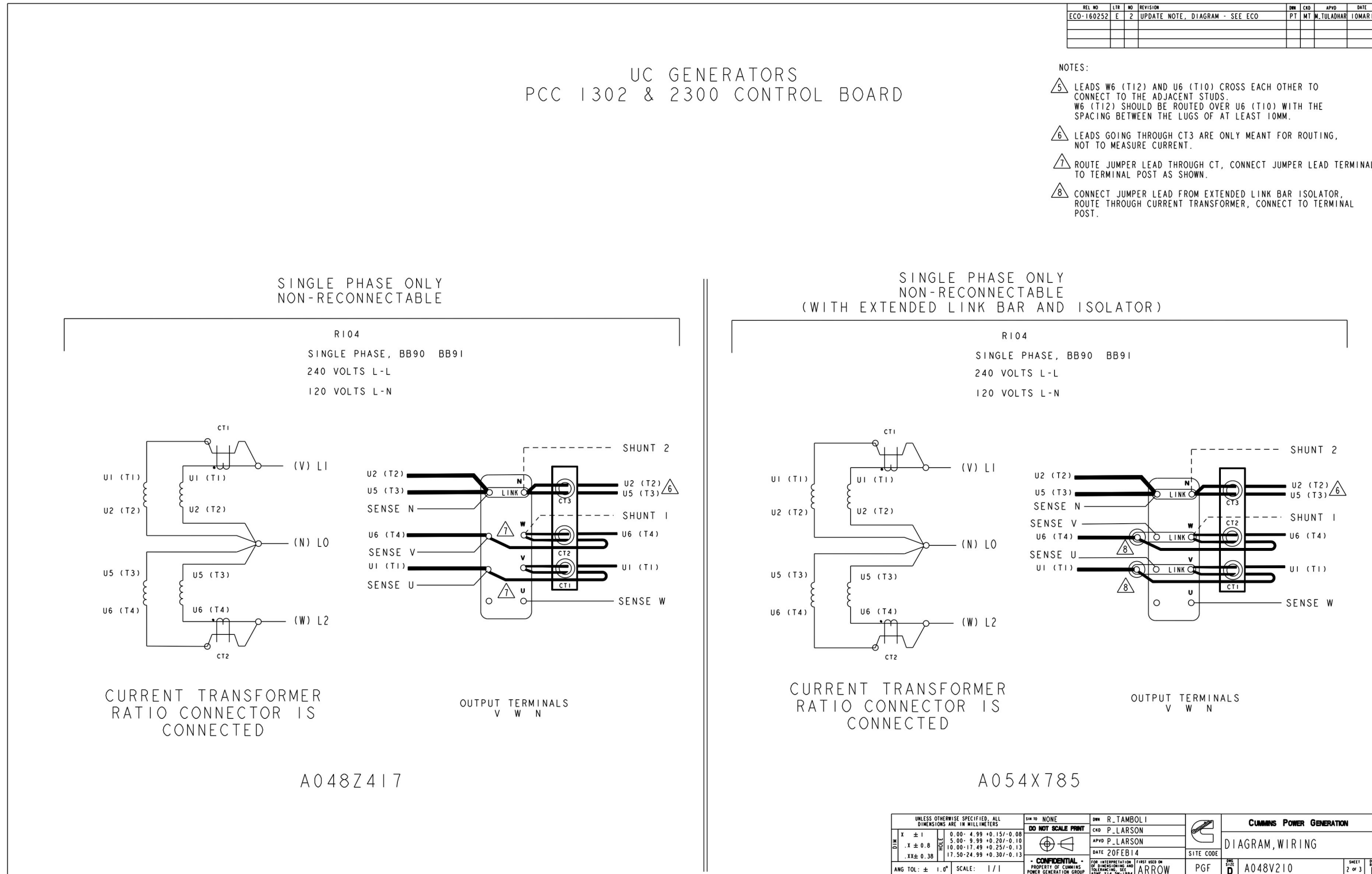

FIGURE 68. PCC 1302/2300 (SHEET 2 OF 3)

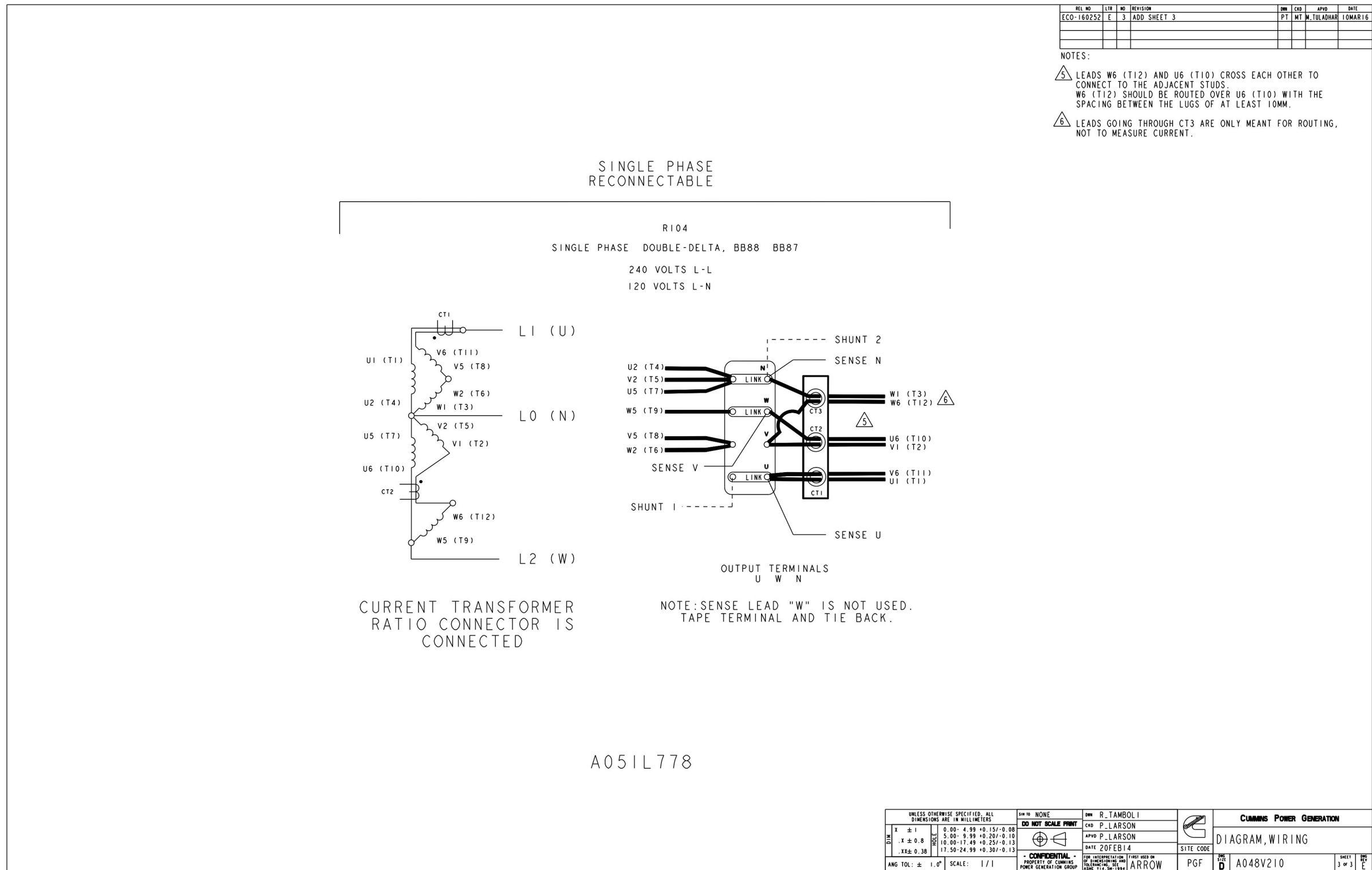

FIGURE 69. PCC 1302/2300 (SHEET 3 OF 3)

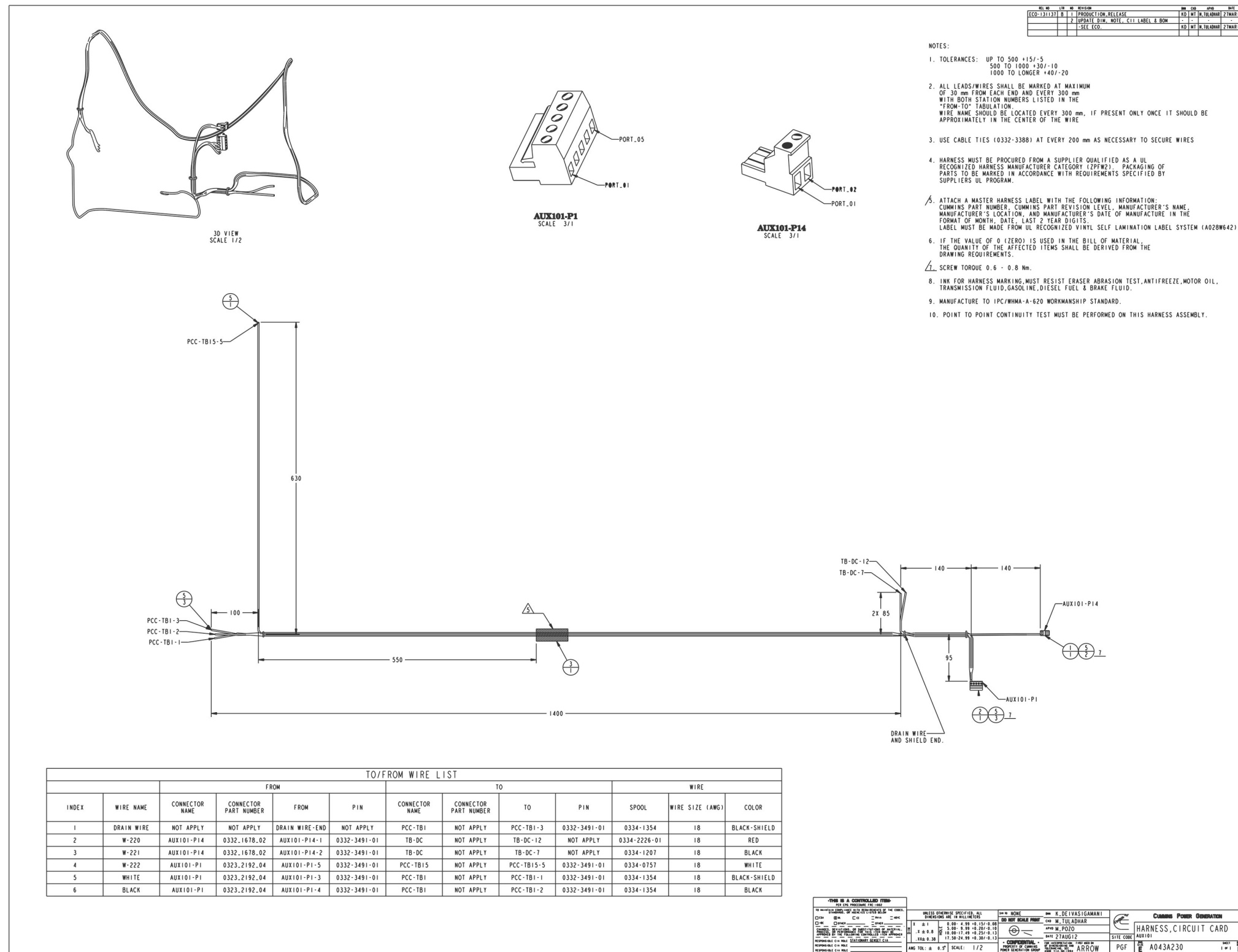

FIGURE 70. CIRCUIT CARD HARNESS (SHEET 1 OF 1)

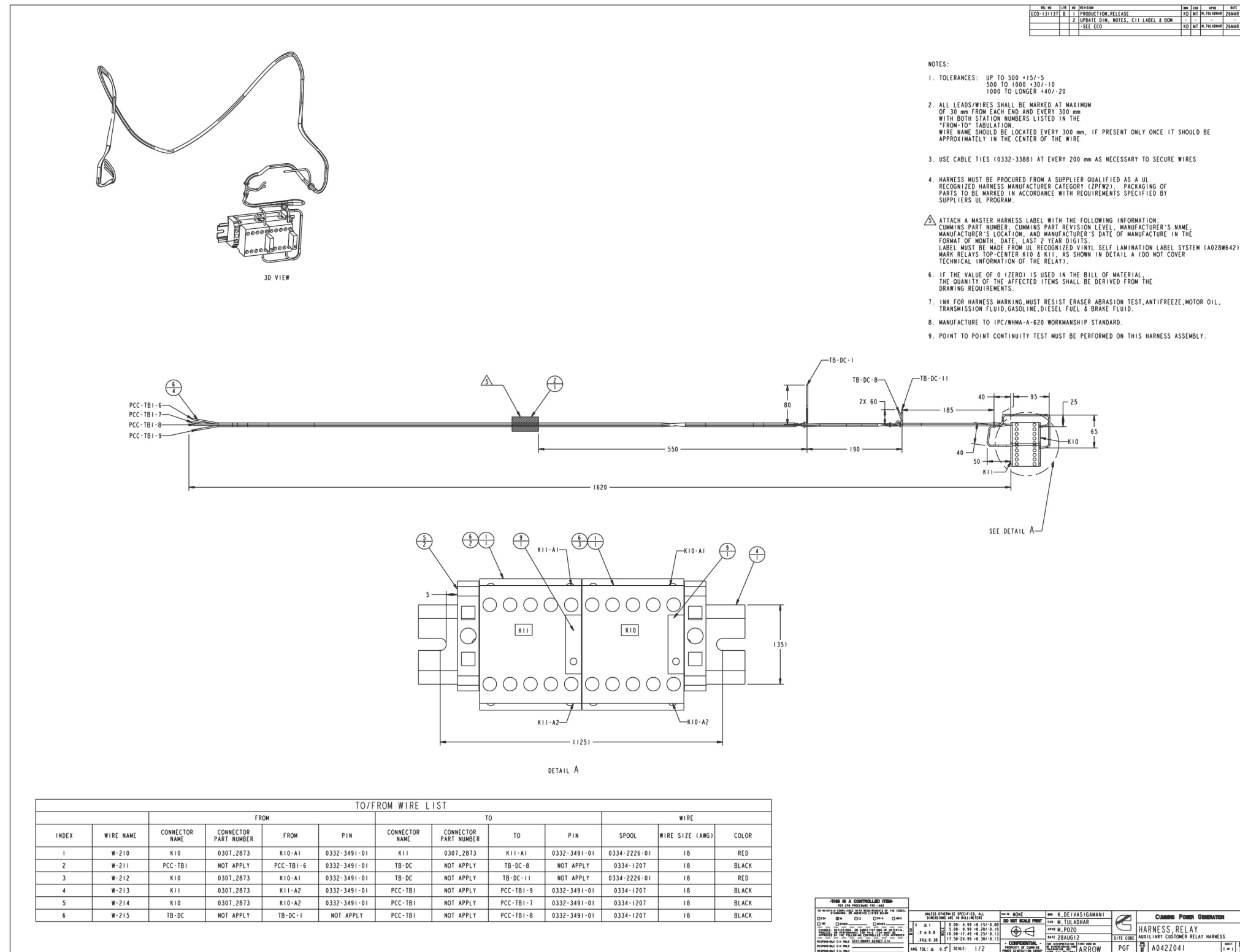

FIGURE 71. RELAY HARNESS (SHEET 1 OF 1)

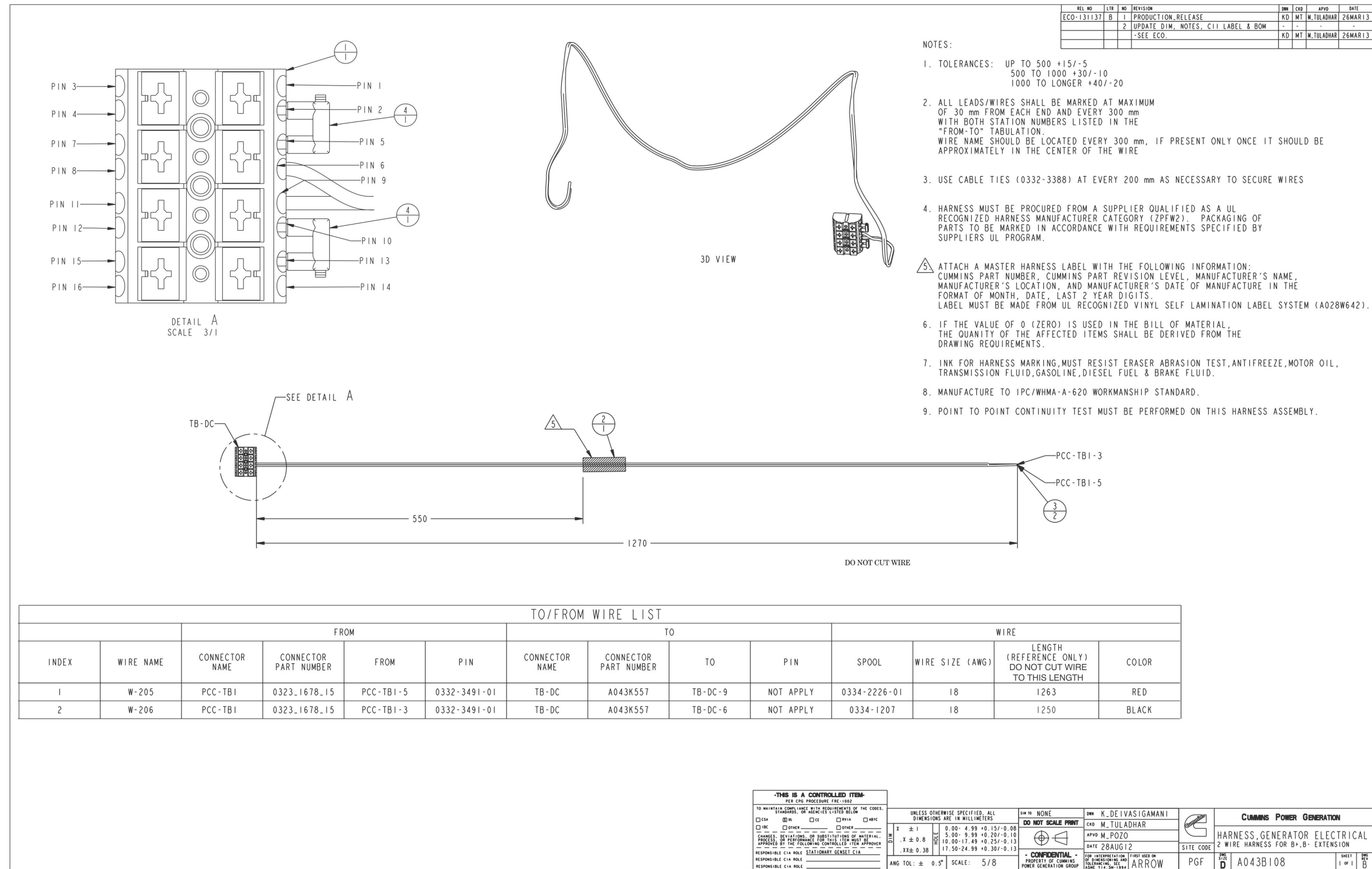

FIGURE 72. GENERATOR ELECTRICAL HARNESS (SHEET 1 OF 1)

This page is intentionally blank.

Appendix D. Seismic Requirements

Table of Contents

| | |
|---|-----|
| Figure 73. Seismic Installation Requirements (Sheet 1 of 4) | 135 |
| Figure 74. Seismic Installation Requirements (Sheet 2 of 4) | 136 |
| Figure 75. Seismic Installation Requirements (Sheet 3 of 4) | 137 |
| Figure 76. Seismic Installation Requirements (Sheet 4 of 4) | 138 |

The drawings included in this section are representative. For current complete information, refer to the drawing package that was shipped with the unit.

D.1 Seismic Installation Instructions

SEISMIC INSTALLATIONS NOTES:

1. THE DESIGN OF POST-INSTALLED ANCHORS IN CONCRETE USED FOR THE COMPONENT ANCHORAGE IS PRE-QUALIFIED FOR SEISMIC APPLICATIONS IN ACCORDANCE WITH "ACI 355.2-07" AND DOCUMENTED IN A REPORT BY A REPUTABLE TESTING AGENCY. (EX. THE EVALUATION SERVICE REPORT ISSUED BY THE INTERNATIONAL CODE COUNCIL)
2. ANCHORS MUST BE INSTALLED TO AN EMBEDMENT DEPTH AS RECOMMENDED IN THE PRE-QUALIFICATION TEST REPORT AS DEFINED IN NOTE 1. FOR "CBC 2013" APPLICATIONS.
3. ANCHORS MUST BE INSTALLED IN MINIMUM 3000 PSI COMPRESSIVE STRENGTH NORMAL WEIGHT STRUCTURAL CONCRETE. CONCRETE AGGREGATE MUST COMPLY WITH "ASTM C33".
4. ANCHORS MUST BE INSTALLED TO THE TORQUE SPECIFICATION AS RECOMMENDED BY THE ANCHOR MANUFACTURER.
5. ANCHORS MUST BE INSTALLED IN LOCATIONS SPECIFIED ON THIS INSTALLATION DRAWING.
6. WASHERS MUST BE INSTALLED AT EACH ANCHOR LOCATION BETWEEN THE ANCHOR HEAD AND EQUIPMENT FOR TENSION LOAD DISTRIBUTION. WASHERS MUST BE TYPE A OR B PLAIN WASHERS MEETING ASME B18.21.1-2009. WASHER SIZE TO MATCH ANCHOR DIAMETER.
7. CONCRETE FLOOR SLAB AND CONCRETE HOUSEKEEPING PADS MUST BE DESIGNED FOR SEISMIC APPLICATIONS IN ACCORDANCE WITH "ACI 318-11".
8. ALL HOUSEKEEPING PAD THICKNESSES MUST BE DESIGNED IN ACCORDANCE WITH THE PRE-QUALIFICATION TEST REPORT AS DEFINED IN NOTE 1 OR A MINIMUM OF 1.5X THE ANCHOR EMBEDMENT DEPTH, WHICHEVER IS LARGEST (UNLESS NOTED OTHERWISE).
9. ALL HOUSEKEEPING PADS MUST BE DOWELLED OR CAST INTO THE BUILDING STRUCTURAL FLOOR SLAB AND DESIGNED FOR SEISMIC APPLICATION PER "ACI 318-11" AND AS APPROVED BY THE STRUCTURAL ENGINEER OF RECORD.
10. FLOOR MOUNTED EQUIPMENT (WITH OR WITHOUT A HOUSEKEEPING PAD) MUST BE INSTALLED TO A STEEL REINFORCED STRUCTURAL CONCRETE FLOOR THAT IS SEISMICALLY DESIGNED AND APPROVED BY THE ENGINEER OF RECORD TO RESIST ALL LOADS FROM EQUIPMENT BEING ANCHORED TO THE FLOOR.
11. COORDINATE REINFORCEMENT OF SUPPORT STRUCTURE WITH EQUIPMENT ANCHOR LOCATIONS.
12. ATTACHING SEISMIC CERTIFIED EQUIPMENT TO FLOOR OTHER THAN THOSE DESIGNED TO ACCEPT THE SEISMIC LOADS FROM CERTIFIED EQUIPMENT BY THE STRUCTURAL ENGINEER OF RECORD IS PROHIBITED.
13. INSTALLATION ONTO A STEEL ROOF STRUCTURE OR MANUFACTURED STEEL CURB SHALL BE COORDINATED WITH THE STRUCTURAL ENGINEER OF RECORD.
14. CONNECTIONS TO THE EQUIPMENT, INCLUDING BUT NOT LIMITED TO CONDUIT, WIRING FROM CABLE TRAYS, OTHER ELECTRICAL SERVICES OR OTHER CONNECTIONS, ARE THE RESPONSIBILITY OF THE INSTALLING CONTRACTOR AND BEYOND THE SCOPE OF THIS DOCUMENT. FLEXIBLE ATTACHMENTS MUST BE USED FOR SEISMIC CONNECTIONS TO ISOLATED COMPONENTS OR ISOLATED EQUIPMENT. THE FLEXIBLE ATTACHMENT MUST PROVIDE FOR ENOUGH RELATIVE DISPLACEMENT TO REMAIN CONNECTED TO THE EQUIPMENT AND FUNCTIONAL DURING AND AFTER A SEISMIC EVENT.
15. REFER TO GENSET OUTLINE DRAWINGS FOR WEIGHT, CG AND CONFIGURATION SPECIFICS.

| REL NO | LTR | NO | REVISION | DWG | CRD | APVD | DATE |
|------------|-----|----|----------------------------------|-----|-----|------|---------|
| ECO-152302 | C | 1 | RMV REBAR REINFORCED FROM NOTE 7 | RAH | ELN | E | OSMAY15 |
| | | 2 | ADD NOTE 15 | RAH | ELN | E | OSMAY15 |
| | | 3 | SEE SHEET 2 | RAH | ELN | E | OSMAY15 |
| | | 4 | SEE SHEET 2 | RAH | ELN | E | OSMAY15 |
| | | 5 | SEE SHEET 2 | RAH | ELN | E | OSMAY15 |
| | | 6 | SEE SHEET 2 | RAH | ELN | E | OSMAY15 |
| | | 7 | SEE SHEET 2 | RAH | ELN | E | OSMAY15 |
| | | 8 | SEE SHEET 2 | RAH | ELN | E | OSMAY15 |
| | | 9 | SEE SHEET 4 | RAH | ELN | E | OSMAY15 |
| | | 10 | SEE SHEET 4 | RAH | ELN | E | OSMAY15 |

| | | | | | | | | |
|--|--|---|--|--|---|--------------|--|--------------|
| -THIS IS A CONTROLLED ITEM- PER CPG PROCEDURE FRI-1002 | | UNLESS OTHERWISE SPECIFIED, ALL DIMENSIONS ARE IN MILLIMETERS | | SMA 10 NONE | DWN D HOFMEISTER | | CUMMINS POWER GENERATION | |
| TO MAINTAIN COMPLIANCE WITH REQUIREMENTS OF THE CODES, STANDARDS, OR AGENCIES LISTED BELOW: <input type="checkbox"/> CSA <input type="checkbox"/> IEC <input type="checkbox"/> CE <input type="checkbox"/> NFPA <input type="checkbox"/> ASME | | X ± 1 0.00-4.99 +0.15/-0.08 X ± 0.8 5.00-9.99 +0.20/-0.10 X ± 0.5 10.00-17.49 +0.25/-0.13 X ± 0.38 17.50-24.99 +0.30/-0.13 | | DO NOT SCALE PRINT | CRD D HOFMEISTER | | INSTALLATION, GENSET SEISMIC REQUIREMENTS | |
| CHANGES, DEVIATIONS, OR SUBSTITUTIONS OF MATERIAL, APPROVED BY THE FOLLOWING CONTROLLED ITEM APPROVER: RESPONSIBLE CIA ROLE: SEISMIC | | ANG TOL: ± 1.0° SCALE: 1/1 | | | APVD E NORDSTROM | DATE 28FEB15 | | |
| RESPONSIBLE CIA ROLE: _____ | | | | CONFIDENTIAL PROPERTY OF CUMMINS POWER GENERATION GROUP | FOR INTERPRETATION, FIRST USED ON DATE 28FEB15 | | DWN D | SHEET 1 OF 4 |
| RESPONSIBLE CIA ROLE: _____ | | | | ARROW | | A05INI57 | C | |

FIGURE 73. SEISMIC INSTALLATION REQUIREMENTS (SHEET 1 OF 4)

| REL NO | LET | NO | REVISION | DWN | CHK | APVD | DATE |
|------------|-----|----|---|-----|-----|------|---------|
| ECO-152302 | C | 3 | ADD NOTE TYPE---RECORD. | RAH | ELN | E | 05MAY15 |
| | | 4 | RWV ATTACHMENT TO STEEL COLUMN FROM TABLE | RAH | ELN | E | 05MAY15 |
| | | 5 | ZONE B5.ADD VALUES TO EVALUATION PARAMETERS | RAH | ELN | E | 05MAY15 |
| | | 6 | ZONE C4.GRADE/ROOF WAS ROOF | RAH | ELN | E | 05MAY15 |
| | | 7 | ZONE B3.ADD VALUES TO EVALUATION PARAMETERS | RAH | ELN | E | 05MAY15 |
| | | 8 | ZONE B3.ASTM A325N OR A490 WAS 307 | RAH | ELN | E | 05MAY15 |

| GRADE MOUNTED GENERATOR SETS | | | | | | |
|---|---|--|------------------|------------------|----------------|-----------------------------|
| CUMMINS GENSET MODEL | CONFIGURATION | ATTACHMENT TO CONCRETE | | | | |
| | | EVALUATION PARAMETERS | CONCRETE ANCHORS | ANCHOR EMBEDMENT | ANCHOR SPACING | DISTANCE TO NEAREST EDGE |
| C45 N6 C50 N6 C60 N6 C70 N6 C80 N6 C100 N6 | GENERATOR SET WITH OR WITHOUT ENCLOSURE | CBC 2013/IBC 2012 Sds <= 2.5 Ip <= 1.5 ap/Rp <= 2.5/2.0 z/h = 1.0 Ω = 2.5 | | | | SEE NOTE |

NOTE: TYPE OF ANCHOR, ANCHOR ATTACHMENT SPECIFICS AND MINIMUM SLAB THICKNESS TO BE DESIGNED BY ENGINEER OF RECORD.

| GRADE/ROOF MOUNTED GENERATOR SETS | | | |
|---|---|--|---|
| CUMMINS GENSET MODEL | CONFIGURATION | ATTACHMENT TO STEEL | |
| | | EVALUATION PARAMETERS | STEEL BOLTS |
| C45 N6 C50 N6 C60 N6 C70 N6 C80 N6 C100 N6 | GENERATOR SET WITH OR WITHOUT ENCLOSURE | CBC 2013/IBC 2012 Sds <= 2.5 Ip <= 1.5 ap/Rp <= 2.5/2.0 z/h <= 1.0 | (QTY 4) 5/8" DIAMETER ASTM A325N OR A490 BOLTS WITH WASHERS THROUGH THE BASE RAIL MOUNTING HOLES. |

| | | | | | |
|---|--|--|----------------------|--------------------------|--------------|
| UNLESS OTHERWISE SPECIFIED, ALL DIMENSIONS ARE IN MILLIMETERS. | | SH TO NONE | DWN D HOFMEISTER | CUMMINS POWER GENERATION | |
| DO NOT SCALE PRINT | | CD D HOFMEISTER | INSTALLATION, GENSET | | |
| DATE 28FEB15 | | APVD E NORDSTROM | SEISMIC REQUIREMENTS | | |
| ANG TOL: ± 1.0° | | SCALE: 1/1 | DATE 28FEB15 | SITE CODE | SHEET 2 OF 4 |
| FOR INTERPRETATION OF DIMENSIONS AND TOLERANCES, SEE ASME Y14.5M-1994 | | PROPERTY OF CUMMINS POWER GENERATION GROUP | ARROW | PGF | A051N157 |

FIGURE 74. SEISMIC INSTALLATION REQUIREMENTS (SHEET 2 OF 4)

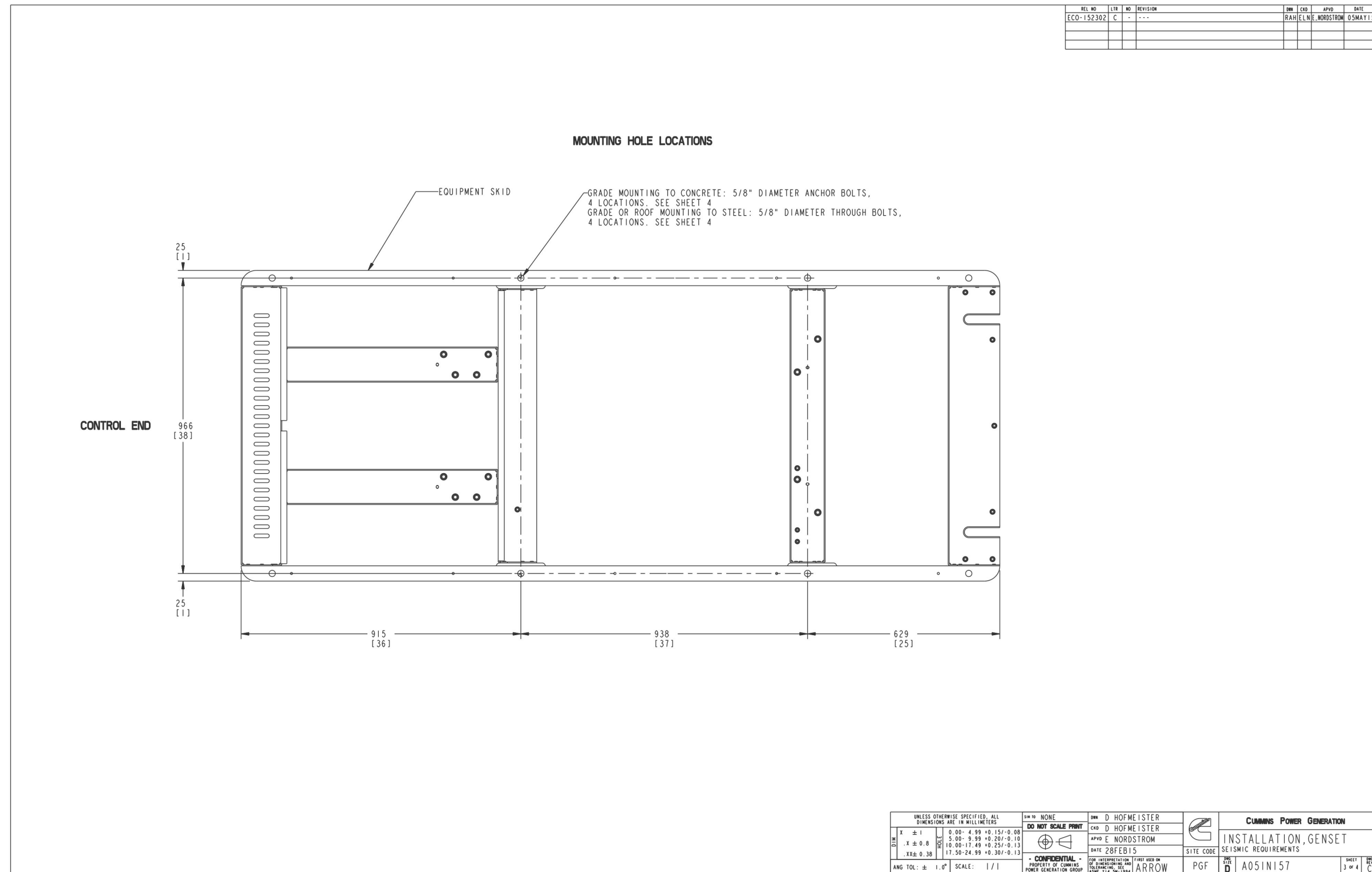

FIGURE 75. SEISMIC INSTALLATION REQUIREMENTS (SHEET 3 OF 4)

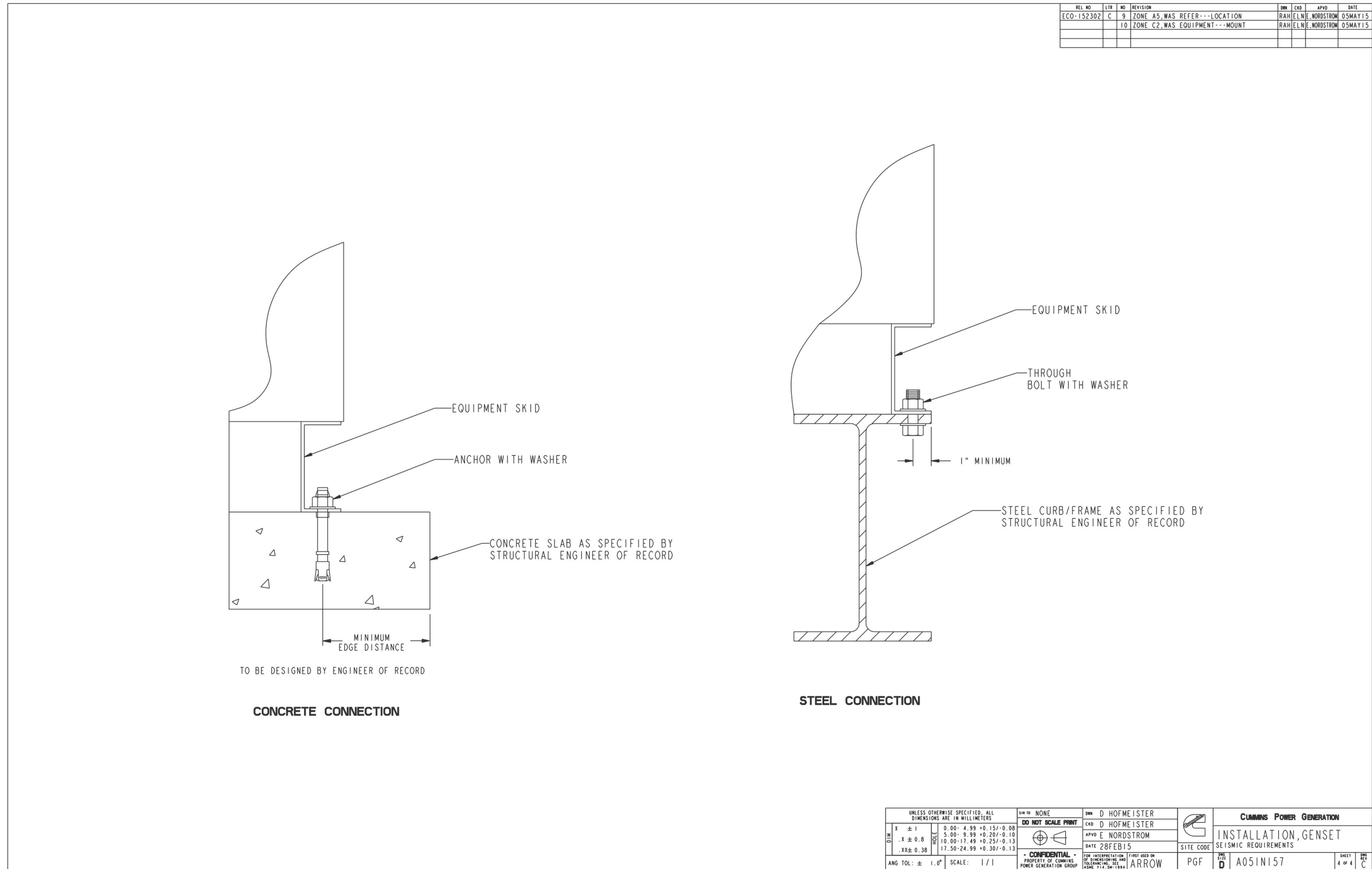

FIGURE 76. SEISMIC INSTALLATION REQUIREMENTS (SHEET 4 OF 4)

power.cummins.com

Copyright © 2017 Cummins Inc. All rights reserved.

Cummins Power Generation, the "C" logo, and Cummins are trademarks of Cummins Inc.

PowerCommand, AmpSentry, InPower and "Our energy working for you." are trademarks of Cummins Power Generation Inc.

Other company, product, or service names may be trademarks or service marks of others.

Specifications are subject to change without notice.

