

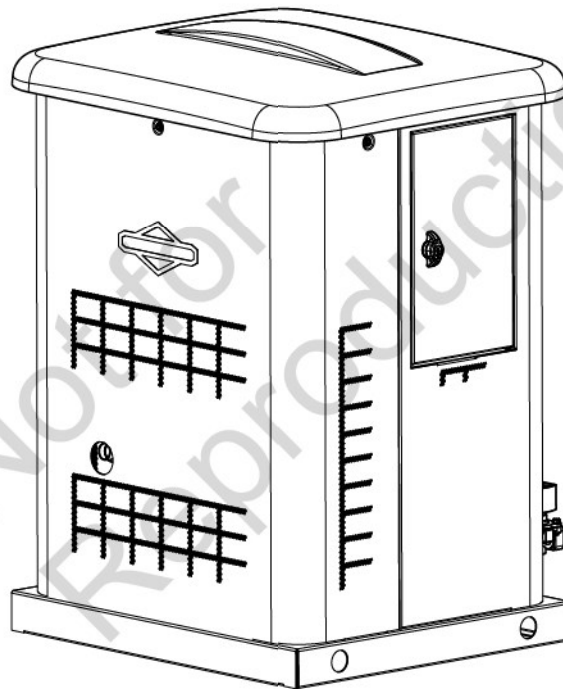

Standby Generator System 12kW
Model 040517-00

BRIGGS & STRATTON INSTALLATION AND START-UP MANUAL STANDBY GENERATOR SYSTEM



80011759 Rev -

Thank you for purchasing this quality-built Briggs & Stratton® home generator. We're pleased that you've placed your confidence in the Briggs & Stratton® brand. When operated and maintained according to the instructions in the operator's manual, your home generator will provide many years of dependable service.

This manual contains safety information to make you aware of the hazards and risks associated with standby generators and how to avoid them. This product is only for use as an optional generator system which provides an alternate source of electric power and to serve loads such as heating, refrigeration systems, and communication systems that, when stopped during any power outage, could cause discomfort or inconvenience.

Save these original instructions for future reference.

This generator requires professional installation before use. The installer should follow the instructions completely.

Where to Find Us

You never have to look far to find Briggs & Stratton support and service for your generator. Consult your Yellow Pages. There are thousands of Briggs & Stratton authorized service dealers worldwide who provide quality service. You can also contact Technical Service by phone at **800 743-4115**, or click on Find a Dealer at BRIGGSandSTRATTON.COM, which provides a list of authorized dealers.

For Future Reference

Please fill out the information below and keep with your receipt to assist in unit identification for future purchase issues.

DATE OF PURCHASE

GENERATOR

Model Number

Model Revision

Serial Number

ENGINE

Model Number

Table of Contents

Safety Rules	4
Installation	7
Delivery Inspection	8
Shipment Contents	8
Installation Checklist - Briggs & Stratton Home Generator Systems	9
Generator Placement	11
Placement of Standby Generator to REDUCE THE RISK OF CARBON MONOXIDE POISONING ...	12
Placement of Standby Generator to REDUCE THE RISK OF FIRE	14
Other General Location Guidelines	16
Electrical and Fuel Inlet Locations	17
Lifting the Generator	18
Concrete Anchoring of Unit	18
Access Panels	19
The Gaseous Fuel System	21
System Connectors	25
Communication Connections	26
Generator AC Connection System	26
Grounding the Generator	27
Power Connections from Generator to Transfer Switch	27
System Control Board	28
Menu	29
General Set Up Screen	30
Control Panel Prompts	31
Advanced Settings Screen	32
Service Code Detection System	33
Final Installation Considerations	33
Initial Start-up (No Load)	34
Operation	35
Automatic Operation Sequence	35
Setting Exercise Timer	35
Optional Wireless Monitor (Sold Separately)	36
Installation Inspection	39
Schematic / Wiring Diagrams	40

Safety Rules

Important Safety Instructions

SAVE THESE INSTRUCTIONS - This manual contains important instructions that should be followed during installation and maintenance of the generator and batteries.



Explosion



Fire



Electrical Shock



Toxic Fumes



Rotating Parts



Hot Surface



Auto Start



Explosive Pressure



Chemical Burn



Lift Hazard



Read Manual

The manufacturer cannot possibly anticipate every possible circumstance that might involve a hazard. The warnings in this manual, and the tags and decals affixed to the unit are, therefore, not all-inclusive. If you use a procedure, work method or operating technique that the manufacturer does not specifically recommend, you must satisfy yourself that it is safe for you and others. You must also make sure that the procedure, work method or operating technique that you choose does not render the generator system unsafe.

⚠ WARNING Running engine gives off carbon monoxide, an odorless, colorless, poison gas.

 Breathing carbon monoxide could result in death, serious injury, headache, fatigue, dizziness, vomiting, confusion, seizures, nausea or fainting.

- Operate this product **ONLY** outdoors in an area that will not accumulate deadly exhaust gas.
- Keep exhaust gas away from any windows, doors, ventilation intakes, soffit vents, crawl spaces, open garage doors or other openings that can allow exhaust gas to enter inside or be drawn into a potentially occupied building or structure.
- Carbon monoxide detector(s) **MUST** be installed and maintained indoors according to the manufacturer's instructions/ recommendations. Smoke alarms cannot detect carbon monoxide gas.

⚠ WARNING The engine exhaust from this product contains chemicals known to the State of California to cause cancer, birth defects, or other reproductive harm.

⚠ WARNING Certain components in this product and related accessories contain chemicals known to the State of California to cause cancer, birth defects, or other reproductive harm. Wash hands after handling.

Safety Symbols and Meanings

⚠ The safety alert symbol indicates a potential personal injury hazard. A signal word (DANGER, WARNING, or CAUTION) is used with the alert symbol to designate a degree or level of hazard seriousness. A safety symbol may be used to represent the type of hazard. The signal word NOTICE is used to address practices not related to personal injury.

⚠ DANGER indicates a hazard which, if not avoided, *will* result in death or serious injury.

⚠ WARNING indicates a hazard which, if not avoided, *could* result in death or serious injury.

⚠ CAUTION indicates a hazard which, if not avoided, *could* result in minor or moderate injury.

NOTICE addresses practices not related to personal injury.

 **WARNING** Storage batteries give off explosive hydrogen gas during recharging. Slightest spark will ignite hydrogen and cause explosion, resulting in death or serious injury.

Battery electrolyte fluid contains acid and is extremely caustic. Contact with battery contents could cause severe chemical burns.

A battery presents a risk of electrical shock and high short circuit current.

- DO NOT dispose of battery in a fire. Recycle battery.
- DO NOT allow any open flame, spark, heat, or lit cigarette during and for several minutes after charging a battery.
- DO NOT open or mutilate the battery.
- Wear protective goggles, rubber apron, rubber boots and rubber gloves.
- Remove watches, rings, or other metal objects.
- Use tools having insulated handles.

 **WARNING** Propane and Natural Gas are extremely flammable and explosive, which could cause burns, fire or explosion resulting in death or serious injury.

- Install the fuel supply system according to NFPA 37 and other applicable fuel-gas codes.
- Before placing the generator into service, the fuel system lines must be properly purged and leak tested.
- After the generator is installed, you should inspect the fuel system periodically.
- NO leakage is permitted.
- DO NOT operate engine if smell of fuel is present or other explosive conditions exist.
- DO NOT smoke around the generator. Wipe up any oil spills immediately. Ensure that no combustible materials are left in the generator compartment. Keep the area near the generator clean and free of debris.

 **WARNING** Generator produces hazardous voltage. Failure to properly ground generator could result in electrocution.

 Failure to isolate generator from utility power could result in death or serious injury to electric utility workers due to backfeed of electrical energy.

- When using generator for backup power, notify utility company.
- DO NOT touch bare wires or bare receptacles.
- DO NOT use generator with electrical cords which are worn, frayed, bare or otherwise damaged.
- DO NOT handle generator or electrical cords while standing in water, while barefoot, or while hands or feet are wet.
- If you must work around a unit while it is operating, stand on an insulated dry surface to reduce the risk of a shock hazard.
- DO NOT allow unqualified persons or children to operate or service generator.
- In case of an accident caused by electrical shock, immediately shut down the source of electrical power and contact the local authorities. **Avoid direct contact with the victim.**
- Despite the safe design of the residential generator, operating this equipment imprudently, neglecting its maintenance or being careless could cause possible injury or death.
- Remain alert at all times while working on this equipment. Never work on the equipment when you are physically or mentally fatigued.
- Before performing any maintenance on the generator, disconnect the battery cable indicated by a **NEGATIVE, NEG** or **(-)** first. When finished, reconnect that cable last.
- After your system is installed, the generator may crank and start without warning any time there is a power failure. To prevent possible injury, always set the generator's system switch to **OFF**, remove the service disconnect from the disconnect box **AND** remove the 15 Amp fuse **BEFORE** working on the equipment.

 **WARNING** Unintentional sparking could cause fire or electric shock resulting in death or serious injury.

WHEN ADJUSTING OR MAKING REPAIRS TO YOUR GENERATOR

- Disconnect the spark plug wire from the spark plug and place the wire where it cannot contact spark plug.

WHEN TESTING FOR ENGINE SPARK

- Use approved spark plug tester.
- DO NOT check for spark with spark plug removed.

 **WARNING** Exhaust heat/gases could ignite combustibles or structures resulting in death or serious injury.



Contact with muffler area could cause burns resulting in serious injury.

- DO NOT touch hot parts and AVOID hot exhaust gases.
- Allow equipment to cool before touching.
- Exhaust outlet side of weatherproof enclosure must have at least 5 ft (1.5 m) minimum clearance from any structure, shrubs, trees or any kind of vegetation.
- Standby generator weatherproof enclosure must be at least 5 ft from windows, doors, any wall opening, shrubs or vegetation over 12 inches (30.48 cm) in height.
- Standby generator weatherproof enclosure must have a minimum of 5 ft (1.5 m) overhead clearance from any structure, overhang or trees.
- DO NOT place weatherproof enclosure under a deck or other type of structure that may confine airflow.
- USE ONLY flexible steel fuel line provided. Connect provided fuel line to generator, DO NOT use with or substitute any other flexible fuel line.
- Smoke detector(s) MUST be installed and maintained indoors according to the manufacturer's instructions/ recommendations. Carbon monoxide alarms cannot detect smoke.
- Keep at least minimum distances shown in *Generator Placement* to insure for proper generator cooling and maintenance clearances.
- It is a violation of California Public Resource Code, Section 4442, to use or operate the engine on any forest-covered, brush-covered, or grass-covered land unless the exhaust system is equipped with a spark arrester, as defined in Section 4442, maintained in effective working order. Other states or federal jurisdictions may have similar laws. Contact the original equipment manufacturer, retailer, or dealer to obtain a spark arrester designed for the exhaust system installed on this engine.
- Replacement parts must be the same and installed in the same position as the original parts.

 **WARNING** Starter and other rotating parts could entangle hands, hair, clothing, or accessories resulting in serious injury.



- NEVER operate generator without protective housings, covers, or guards in place.
- DO NOT wear loose clothing, jewelry or anything that could be caught in the starter or other rotating parts.
- Tie up long hair and remove jewelry.
- Before servicing, remove 15 Amp fuse from control panel and disconnect **Negative (NEG or -)** battery cable.

 **CAUTION** Installing the 15 Amp fuse could cause the engine to start at any time without warning resulting in minor or moderate injury.



- Observe that the 15 Amp fuse has been removed from the control panel for shipping.
- DO NOT install this fuse until all plumbing and wiring has been completed and inspected.

 **CAUTION** Excessively high operating speeds could result in minor injury.

Excessively low speeds impose a heavy load on generator.

- DO NOT tamper with governed speed. Generator supplies correct rated frequency and voltage when running at governed speed.
- DO NOT modify generator in any way.

NOTICE Improper treatment of generator could damage it and shorten its life.

- Use generator only for intended uses.
- If you have questions about intended use, contact your authorized dealer.
- Operate generator only on level surfaces.
- Adequate, unobstructed flow of cooling and ventilating air is critical for correct generator operation.
- The access panels/door must be installed whenever the unit is running.
- DO NOT expose generator to excessive moisture, dust, dirt, or corrosive vapors.
- Remain alert at all times while working on this equipment. Never work on the equipment when you are physically or mentally fatigued.
- DO NOT start engine with air cleaner or air cleaner cover removed.
- DO NOT insert any objects through cooling slots.
- DO NOT use the generator or any of its parts as a step. Stepping on the unit could cause stress and break parts. This may result in dangerous operating conditions from leaking exhaust gases, fuel leakage, oil leakage, etc.
- If connected devices overheat, turn them off and disconnect them from generator.
- Shut off generator if:
 - electrical output is lost;
 - equipment sparks, smokes, or emits flames;
 - unit vibrates excessively.
 - unit makes unusual noises.

Installation

This product is only for use as an optional generator system which provides an alternate source of electric power and to serve loads such as heating, refrigeration systems, and communication systems that, when stopped during any power outage, could cause discomfort or inconvenience.

NOTICE This product does NOT qualify for either an emergency standby or legally required standby system as defined by NFPA 70 (NEC).

- Emergency generator systems are intended to automatically supply illumination, power, or both, to designated areas and equipment in the event of failure of the normal supply. Emergency systems may also provide power for such functions as ventilation where essential to maintain life, where current interruption of the normal supply would produce serious life safety or health hazards.
- Legally Required standby generator systems are intended to automatically supply power to selected loads in the event of failure of the normal source

which could create hazards or hamper rescue or fire-fighting operations.

Every effort has been made to ensure that information in this manual is accurate and current. However, we reserve the right to change, alter, or otherwise improve the product and this document at any time without prior notice.

Only current licensed electrical and plumbing professionals should attempt home generator system installations. Installations must strictly comply with all applicable codes, industry standards, laws and regulations.

Home Owner Responsibilities

- Read and follow the instructions given in the operator's manual.
- Follow a regular schedule in maintaining, caring for and using your home generator, as specified in the operator's manual.
- Carbon monoxide detector(s) MUST be installed and maintained indoors according to the manufacturer's instructions/ recommendations. Smoke alarms cannot detect carbon monoxide gas.
- Smoke detector(s) MUST be installed and maintained indoors according to the manufacturer's instructions/ recommendations. Carbon monoxide alarms cannot detect smoke.

Installing Dealer/Contractor Responsibilities

- Read and observe the safety rules.
- Install only an UL approved transfer switch that is compatible with the generator.
- Read and follow the instructions given in this installation and start-up manual.
- Installation must strictly comply with all applicable codes, industry standards, laws, and regulations.
- Allow sufficient room on all sides of the generator for maintenance and servicing.

Cold Weather Kit

If operating the generator below 30°F (-1°C), it is **HIGHLY RECOMMENDED** that a Model 6348 Cold Weather Kit (includes oil warmer and battery warmer) be installed on the 12kW units.

These items are available at your local servicing dealer.

For cold weather areas (below 0°F (-18°C)) it is also recommended that a BCI, Size 24, wet lead-acid battery be used of 800 CCA minimum.

If you need more information on this matter, please call (800) 743-4115, between 8:00 AM and 5:00 PM CT.

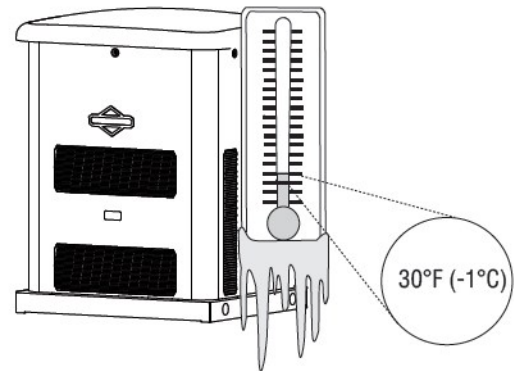

Unpacking Precautions

Avoid damage from dropping, bumping, collision, etc. Store and unpack carton with the proper side up, as noted on the shipping carton.

Delivery Inspection

After removing the carton, carefully inspect the generator for any damage that may have occurred during shipment.

If loss or damage is noted at time of delivery, have the person(s) making delivery note all damage on the freight bill and affix his signature under the consignor's memo of loss or damage. If loss or damage is noted after delivery, separate the damaged materials and contact the carrier for claim procedures. Parts damaged in shipping are not warranted.

Shipment Contents

The home generator system is supplied with:

- Oil (5W30 Synthetic)
- Flexible steel fuel line
- Installation and start-up manual
- Operator's manual
- Spare access keys
- Spare 15 Amp ATO-type fuse
- Battery tie-down strap

Not included:

- Carbon monoxide detector(s)
- Smoke detector(s)
- Starting battery
- Connecting wire and conduit
- Fuel supply valves/plumbing
- Crane, lifting straps, chains or cables
- Two 60' lengths of 3/4" nominal minimum scheduled 40 steel pipe (NOT conduit)
- Torque screwdriver, 5 to 50 inch-pound range
- Voltage/frequency meter
- Two (2) AA batteries for remote wireless monitor
- Remote wireless monitor (Optional)
- Antenna (Optional)

Installation Checklist - Briggs & Stratton Home Generator Systems

Proper installation of the home generator requires the completion of the following tasks:

Carbon Monoxide (CO) Detector/ Smoke Detector

- Carbon Monoxide (CO) detector(s) installed and in working order.
- Smoke detector(s) installed and in working order.

Placement

- Required permits have been obtained.
- Generator placed in an area free from Carbon Monoxide (CO) buildup. See **Placement of Standby Generator to Reduce the Risk of Carbon Monoxide Poisoning.**
- Generator placed in an area compliant to NFPA 37. See **Placement of Standby Generator to Reduce the Risk of Fire.**
- Generator placed in an area free from water damage. See **Other General Location Guidelines.**
- Generator placed in an area free from utility and other home systems. See **Other General Location Guidelines.**
- Generator placed in a debris free zone. See **Other General Location Guidelines.**
- Generator placed on flat ground with provisions for water drainage. See **Other General Location Guidelines.**

Fuel

- Generator is connected to fuel source with steel flexible fuel line, has no fuel leaks and conforms to local codes. See **The Gaseous Fuel System.**
- Proper fuel pressure has been measured with all gas appliances operating. See **The Gaseous Fuel System.**
- Fuel system has been configured for the proper fuel supply: Natural gas (NG) or liquefied petroleum (LP). See **Fuel Conversion.**
- Fuel type: (circle one) **NG** **LP**
- Fuel pipe size used: (circle one) **3/4"** **1"** **1-1/4"** **1-1/2"** See **NFPA 54.**
- Fuel pressure at fuel inlet port with generator on and at full load and all gas appliances turned on and operating _____.

Electrical

- Generator neutral is connected to Automatic Transfer Switch. See **Generator AC Connection System.**
- Generator is grounded. See **Grounding the Generator and NFPA 70,NEC.**
- Generator is connected to the transfer switch with the specified wiring. See **Utility Circuit Connection and Transfer Switch Communication.**
- Generator is connected to the transfer switch with the specified wiring. #18AWG twisted pair wiring from the generator control panel to the transfer switch is installed in a separate conduit from high voltage wires unless the insulation rating on all wiring is rated for 600V See **Transfer Switch Communication.**

- Dipswitches in most transfer switches must be set to correspond to the wattage of the generator. See **Transfer Switch Operator/Installation Manual.**

Operation

- Cold weather kit is installed in temperatures below 30°F (-1°C). See **Cold Weather Kit.**
- Correct battery type is installed and fully charged. See **Final Installation Considerations.**
- Generator engine oil level is at full mark. See **Final Installation Considerations.**
- Circuit breaker is in the ON position.
- Utility was shut off to test the operation of generator and transfer switch. Note any fault codes and make corrections as required.
- AC Voltage Output _____.
- Frequency Output _____.

Owner Information

Name: _____
Address: _____

Phone/e-mail: _____

Unit Information

Generator Model: _____
Generator Serial Number: _____

Installing Contractor Information

Name: _____
Address: _____

Phone/FAX: _____

Electrician: _____

Signature: _____

Plumber: _____

Signature: _____

Inspector Information

Name: _____

Address: _____

Title: _____

Inspection Date: _____

This generator has been installed per the manufacturer's instructions:

Installing Contractor Signature: _____

Date: _____

Intentionally Left Blank

Not for
Reproduction

Generator Placement

Before installing the generator, consult with the homeowner and convey the following requirements, which must be satisfied before the installation is complete.

There are two equally important safety concerns in regards to carbon monoxide poisoning and fire. There are also several general location guidelines that must all be met before the installation is considered complete.

⚠ WARNING Running engine gives off carbon monoxide, an odorless, colorless, poison gas. Breathing carbon monoxide could result in death, serious injury, headache, fatigue, dizziness, vomiting, confusion, seizures, nausea or fainting.

- Operate this product **ONLY** outdoors in an area that will not accumulate deadly exhaust gas.
- Keep exhaust gas away from any windows, doors, ventilation intakes, soffit vents, crawl spaces, open garage doors or other openings that can allow exhaust gas to enter inside or be drawn into a potentially occupied building or structure.
- Carbon monoxide detector(s) **MUST** be installed and maintained indoors according to the manufacturer's instructions/ recommendations. Smoke alarms cannot detect carbon monoxide gas.

Exhaust Side of the Generator

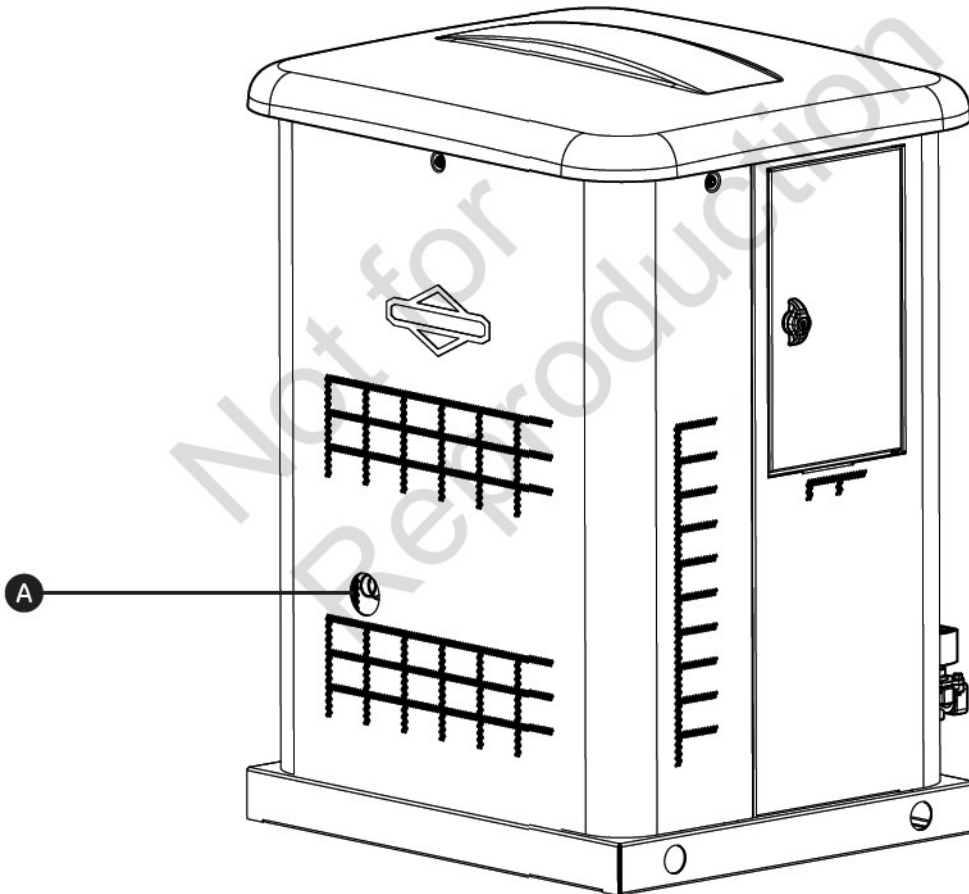

A Exhaust outlet side of weatherproof enclosure.

Placement of Standby Generator to REDUCE THE RISK OF CARBON MONOXIDE POISONING

The arrows in the figure below point to **POTENTIAL** points of entry for Carbon Monoxide Gas.

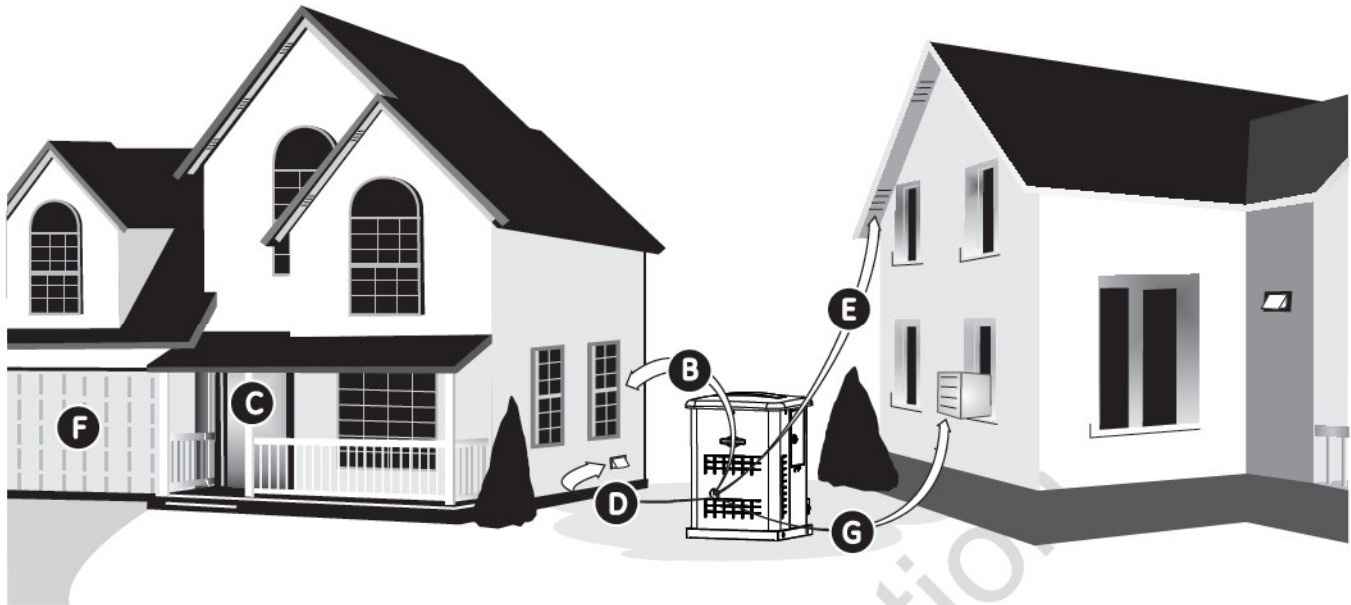

All fossil fuel burning equipment, such as standby generators, contains carbon monoxide (CO) gas in the engine exhaust. CO gas is odorless, colorless and tasteless and is unlikely to be noticed until a person is overcome. CO gas can kill you so it is required that the following is included as part of the installation:

- Install generator outdoors in an area that will not accumulate deadly exhaust gas.
- DO NOT install generator where exhaust gas could accumulate and enter inside or be drawn into a potentially occupied building or structure.
- By law it is required in many states to have a Carbon Monoxide (CO) detector in operating condition in your home. Carbon monoxide detector(s) **A** MUST be installed and maintained indoors according to the manufacturer's instructions/ recommendations. A CO monitor is an electronic device that detects hazardous levels of CO. When there is a buildup of CO, the monitor will alert the occupants by flashing visual indicator light and alarm. Smoke alarms cannot detect CO gas.
- Your neighbor(s) home may be exposed to the engine exhaust from your standby generator and must be considered when installing your standby generator.

- Ensure exhaust gas is kept away from:

- B** windows
- C** doors
- D** ventilation intakes
- E** soffit vents
- F** garage doors
- G** crawl spaces or other openings that can allow exhaust gas to enter inside or be drawn into a potentially occupied building or structure.

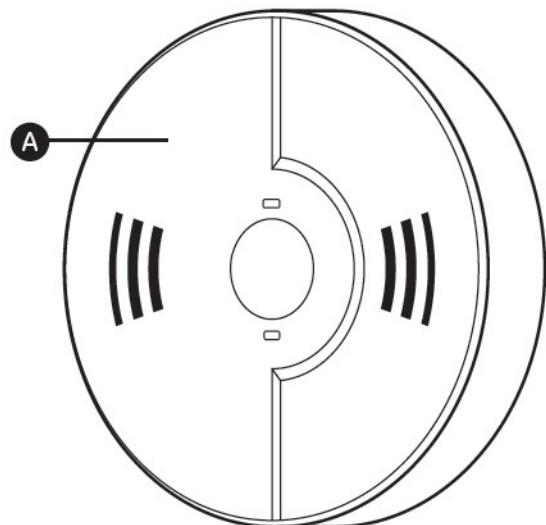

- Direct the standby generator exhaust away from or parallel to the building or structure. **DO NOT** direct the generator exhaust towards a potentially occupied building, structure, windows, doors, ventilation intakes, soffit vents, crawl spaces, open garage doors or other openings where exhaust gas could accumulate and enter inside or be drawn into a potentially occupied building or structure.

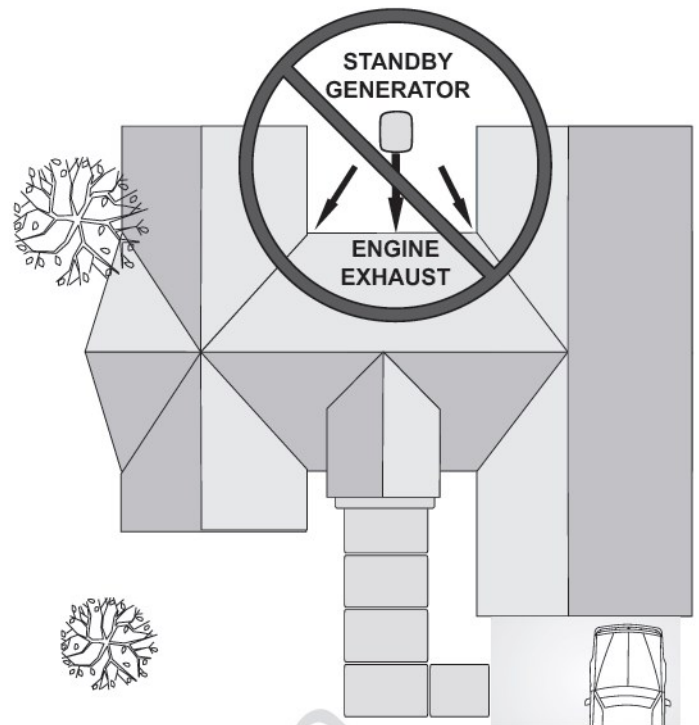

- **DO NOT** place standby generator in any area where leaves or debris normally accumulates. Position standby generator in an area where winds will carry the exhaust gas away from any potentially occupied building or structure.

Not for
Reproduction

Placement of Standby Generator to REDUCE THE RISK OF FIRE

The National Fire Protection Association (NFPA) standard NFPA 37 establishes criteria for minimizing the hazard of fire during the installation and operation of stationary combustion engines. NFPA 37 limits the spacing of an enclosed generator from openings in walls, structures and combustible materials outside the enclosure.

The placement requirements provided are based on compliance to NFPA 37 2010 section 4.1.4 and a full-scale demonstration fire test. Details of compliance testing can be found in section **National Fire Protection Association (NFPA) standard NFPA 37 requirements and testing.**

Examples of standby generator locations to reduce the risk of fire:

Legend for Generator Locations to reduce the risk of fire.

- A** Standby weatherproof enclosure must be at least 5 ft (1.5 m) from windows, doors, any wall opening, shrubs or vegetation over 12 inches (30.5 cm) in height.
- B** Exhaust outlet side of weatherproof enclosure must have at least 5 ft (1.5 m) minimum clearance from any structure, shrubs, trees or any kind of vegetation.
- C** Standby weatherproof enclosure must have a minimum of 5 feet (1.5 m) overhead clearance from any structure, overhang or trees.

NOTICE DO NOT place weatherproof enclosure under a deck or other type of covered structure that may confine airflow.

WARNING Exhaust heat/gases could ignite combustibles or structures resulting in death or serious injury.



- Exhaust outlet side of weatherproof enclosure must have at least 5 ft (1.5 m) minimum clearance from any structure, shrubs, trees or any kind of vegetation.
- Standby generator weatherproof enclosure must be at least 5 ft (1.5 m) from windows, doors, any wall opening, shrubs or vegetation over 12 inches (30.5 cm) in height.
- Standby generator weatherproof enclosure must have a minimum of 5 ft (1.5 m) overhead clearance from any structure, overhang or trees.
- DO NOT place weatherproof enclosure under a deck or other type of structure that may confine airflow.
- USE ONLY flexible steel fuel line provided. Connect provided fuel line to generator, DO NOT use with or substitute any other flexible fuel line.
- Smoke detector(s) MUST be installed and maintained indoors according to the manufacturer's instructions/ recommendations. Carbon monoxide alarms cannot detect smoke.
- DO NOT place weatherproof enclosure in manner other than shown in illustrations.

Vertical Clearances

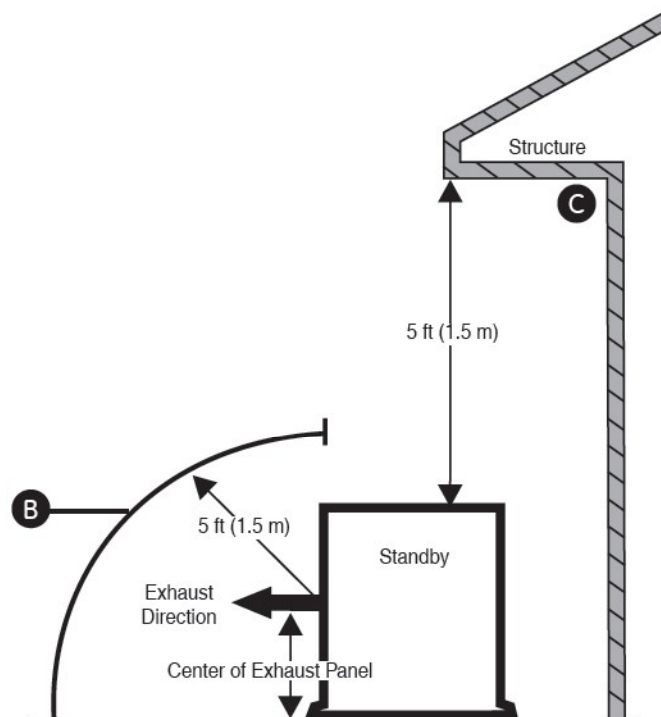

Generator Installations

NOTICE The figures below show the minimum installation distances allowed to structures and items listed in legend.

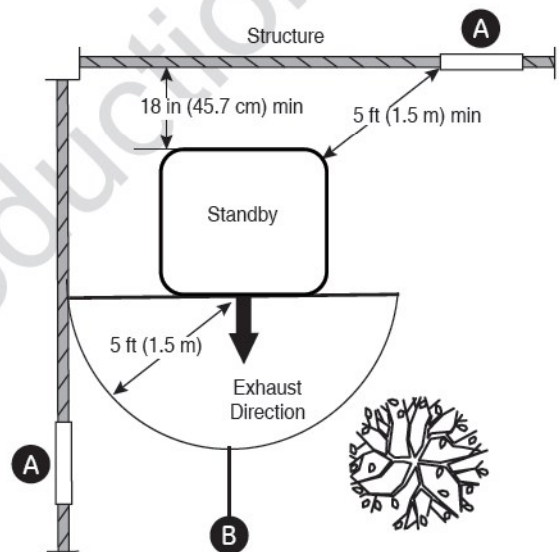
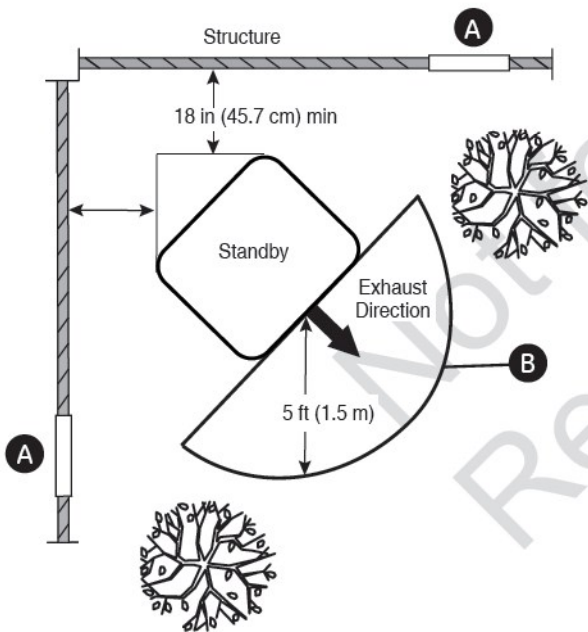
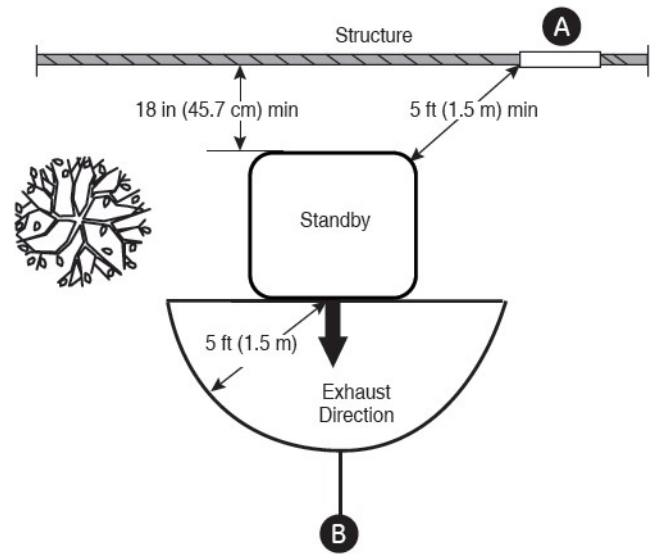
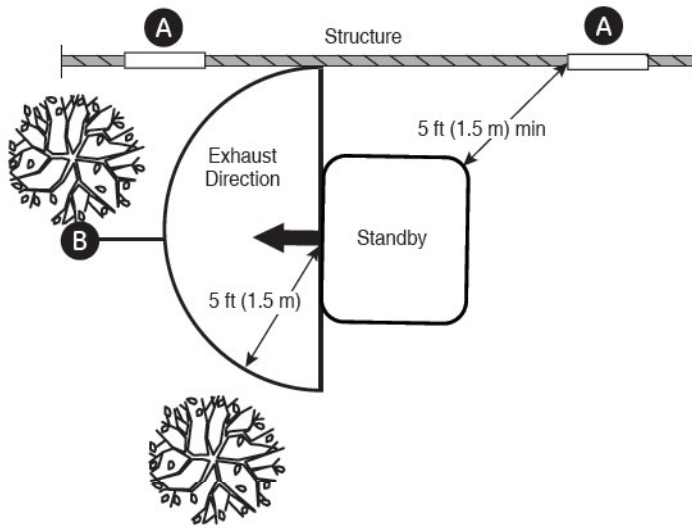

- A** Standby weatherproof enclosure must be at least 5 ft (1.5 m) from windows, doors, any wall opening, shrubs or vegetation over 12 inches (30.5 cm) in height.
- B** Exhaust outlet side of weatherproof enclosure must have at least 5 ft (1.5 m) minimum clearance from any structure, shrubs, trees or any kind of vegetation.
- C** Standby weatherproof enclosure must have a minimum of 5 feet (1.5 m) overhead clearance from any structure, overhang or trees.

NOTICE DO NOT place weatherproof enclosure under a deck or other type of covered structure that may confine airflow.

Other General Location Guidelines

- Place the standby generator in a prepared location that is flat and has provisions for water drainage.
- Install the standby generator in a location where sump pump discharge, rain gutter down spouts, roof run-off, landscape irrigation, or water sprinklers will not flood the unit or spray the enclosure and enter any air inlet or outlet openings.
- Install the standby generator where it will not affect or obstruct any services (including covered, concealed and underground), such as telephone, electric, fuel (natural gas / LPG vapor), irrigation, air conditioning, cable, septic, sewer, well and so forth.
- Install the standby generator where leaves, grass, snow, etc will not obstruct air inlet and outlet openings. If prevailing winds will cause blowing or drifting, you may need to construct a windbreak to protect the unit.

National Fire Protection Association (NFPA) Standard NFPA 37 Requirements and Testing

Requirements:

NFPA 37 2010, section 4. 1. 4, Engines Located Outdoors. Engines, and their weatherproof housings if provided, that are installed outdoors shall be located at least 1.5m (5 ft) from openings in walls and at least 1.5 m (5 ft) from structures having combustible walls. A minimum separation shall not be required where either of the following conditions exist:

1. The adjacent wall of the structure has a fire resistance rating of at least 1 hour.
2. The weatherproof enclosure is constructed of noncombustible materials and it has been demonstrated that a fire within the enclosure will not ignite combustible materials outside the enclosure.*

such as those given in NFPA 555, *Guide on Methods for Evaluating Potential for Room Flashover*.

To comply with condition 2, the weatherproof enclosure has been constructed completely of non-combustible materials and full-scale fire tests have been conducted to demonstrate that a fire within the enclosure will not ignite combustible materials outside the enclosure.

Annex A Explanatory Material

A.4.1.4 (2) Means of demonstrating compliance are by means of full-scale fire tests or by calculation procedures,

Electrical and Fuel Inlet Locations

The 3/4 inch N.P.T. fuel inlet connector **A** and electrical inlet location **B** is shown below.

A 1/2 inch knock-out is provided for the electrical inlet. This inlet may be enlarged or supplemented to accommodate a maximum conduit size of 1 1/2 inches. Ensure that the installed conduit(s) enter the unit in the zone shown in the drawing such that they properly enter the electrical box.

The home generator is supplied with a base that, unless mandated by local code, does not require a concrete slab.

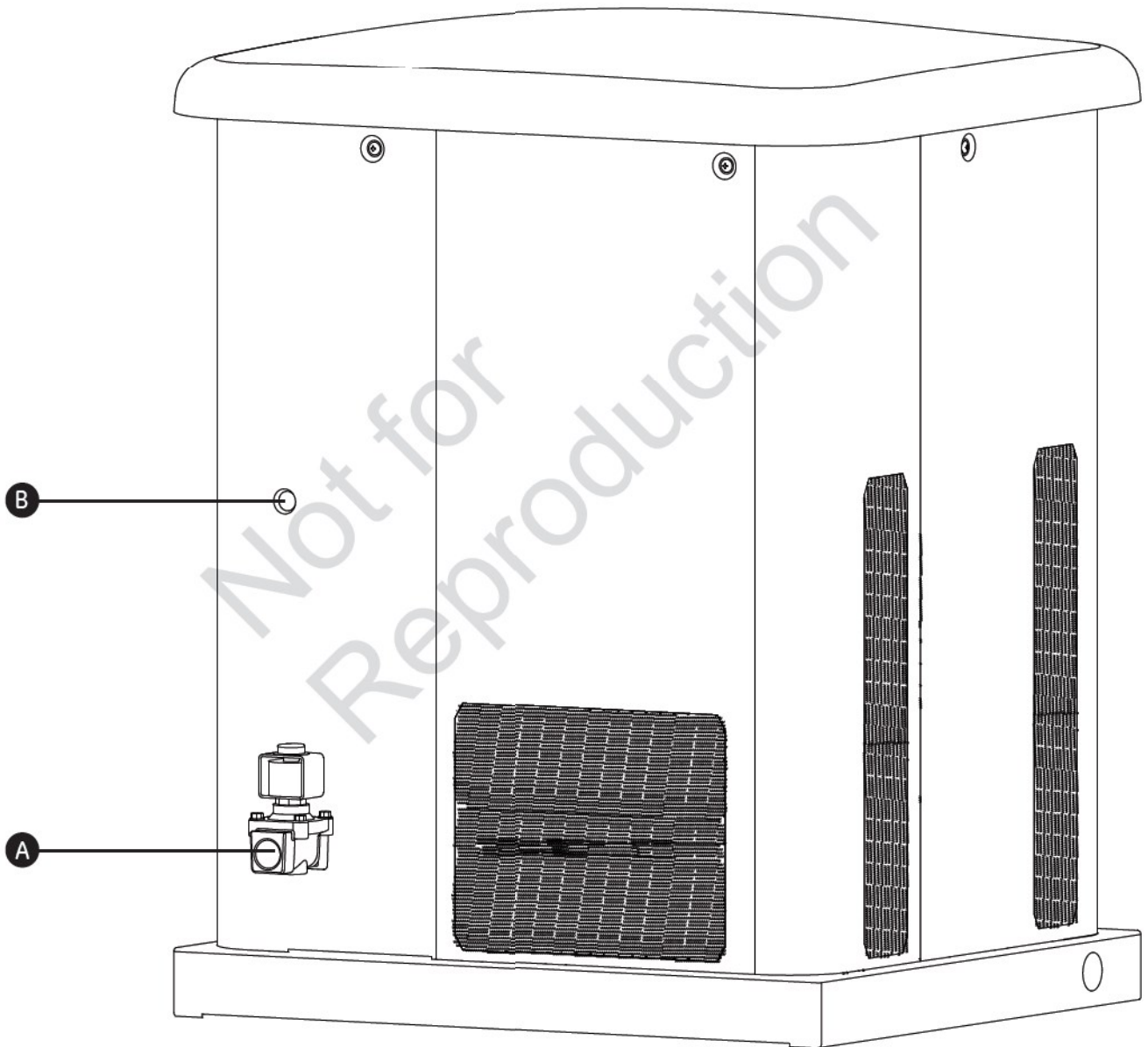

Lifting the Generator

The generator weighs more than 330 pounds (150 kg). Proper tools, equipment and qualified personnel should be used in all phases of handling and moving the generator.

▲ WARNING Hazardous Voltage - Contact with power lines could cause electric shock or burn, resulting in death or serious injury.
Lifting Hazard / Heavy Object - Could result in serious injury.

- If lifting or hoisting equipment is used, DO NOT contact any power lines.
- DO NOT lift or move generator without assistance.
- Use lifting pipes as described in *Lifting the Generator*.
- DO NOT lift unit by roof as damage to generator will occur.

Two 60" lengths of 3/4" nominal minimum scheduled 40 steel pipe **A**, supplied by the installer, are required to lift the generator manually. Insert pipes through the lifting holes **B** located near the unit's base.

You may also lift the unit using a "hook and hoist" method attached to the lifting pipes, provided that you use a spreader bar to ensure that the chains or cables DO NOT touch the generator's roof.

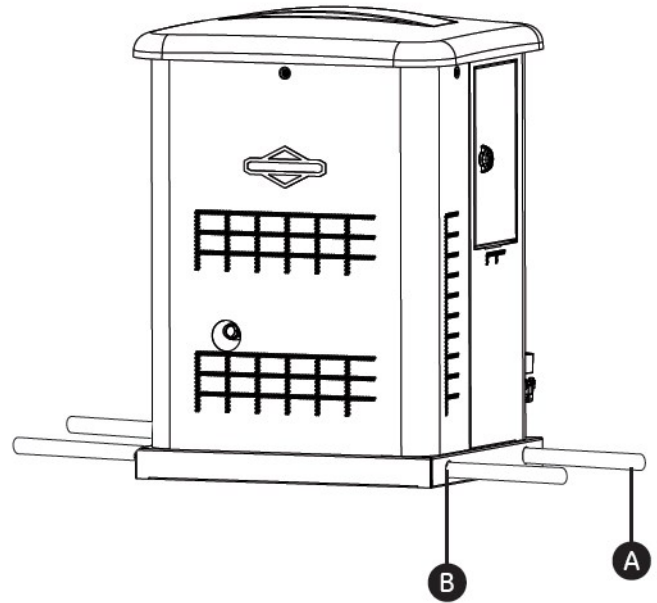

Concrete Anchoring of Unit

In areas determined to be hurricane prone, it is recommended to anchor the standby generator to concrete. The concrete anchors must be rated to hold 800 lbs (kg). There are three 7/16 inch holes **C** located in the base of the generator in which to anchor the unit.

NOTICE Unless mandated by local or state code, a concrete slab is not required.

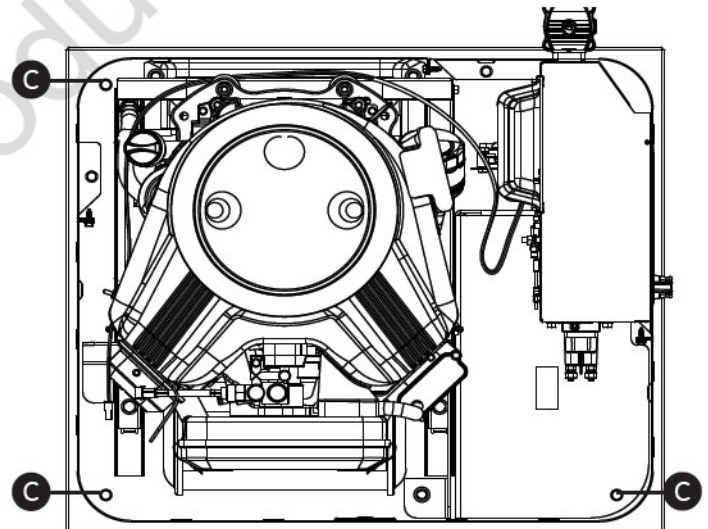

Access Panels

The generator is equipped with an enclosure that has several access panels, as shown.

Front Panel **A** and roof **B** are used to access:

- Battery Compartment
- Engine Oil Drain Hose
- Engine Oil Filter
- Engine Valve Cover
- Spark Plugs

Each generator is shipped with a set of identical keys.

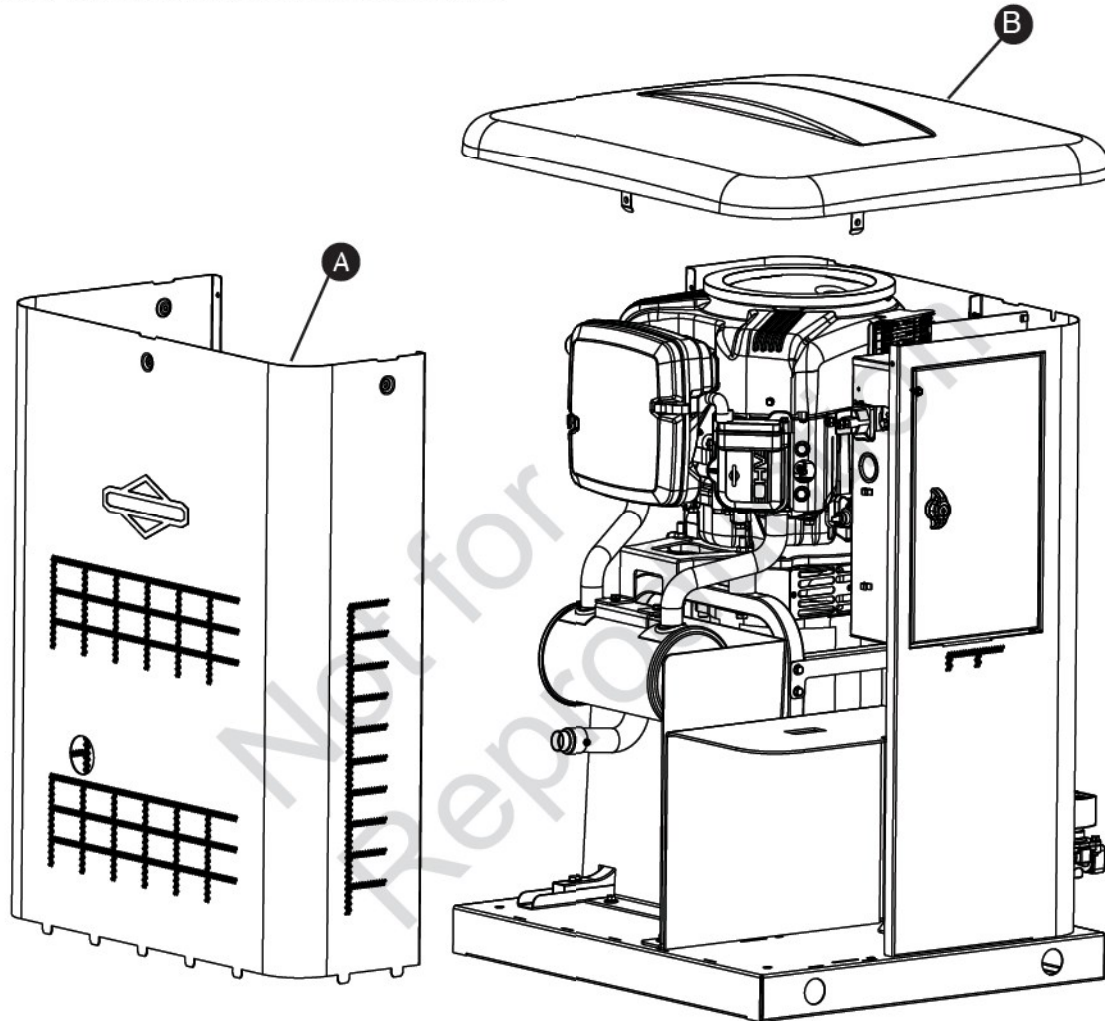

To remove roof:

1. Remove the five screws **A** that secure the roof to the unit.
2. Carefully lift and remove roof from unit.

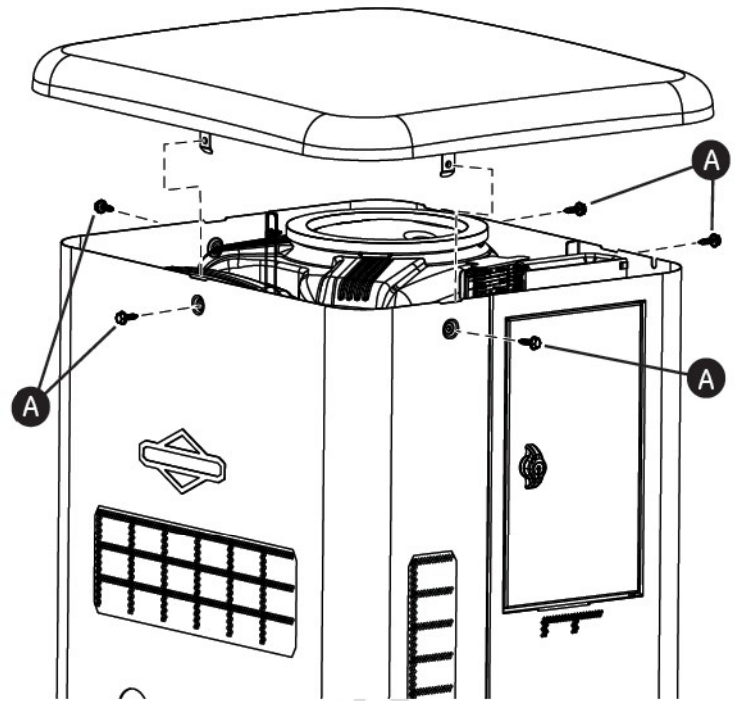

To remove front panel:

1. Remove the two screws **B** that secure the panel to the unit.
2. Lift and flex panel outward and off base. Use caution not to damage the battery box **C**.

To secure front panel:

1. Place panel in unit.
2. Secure the panel with two screws.

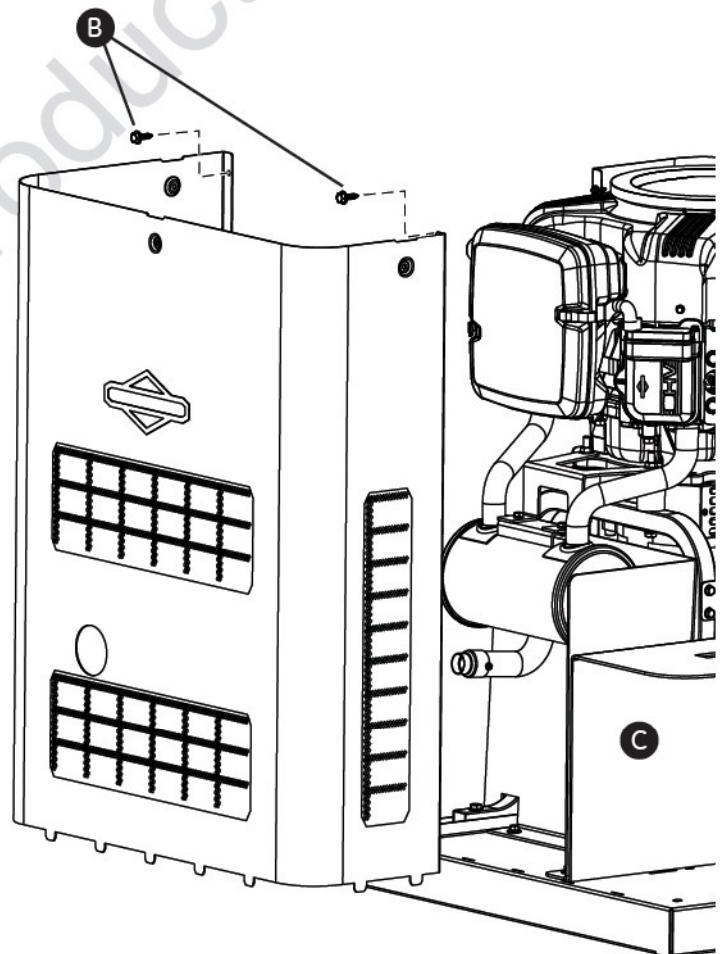

The Gaseous Fuel System

The information below is provided to assist gaseous fuel system technicians in planning installations. In no way should this information be interpreted to override applicable fuel gas codes. Consult with your local fuel supplier or Fire Marshall if questions or problems arise.

▲ WARNING Propane and Natural Gas are extremely flammable and explosive, which could cause burns, fire or explosion resulting in death or serious injury.

- LP gas is heavier than air and will settle in low areas.
- Natural gas is lighter than air and will collect in high areas.
- The slightest spark could ignite these fuels and cause an explosion.
- DO NOT light a cigarette or smoke.

TO THE INSTALLER: Consult with the generator owner(s) and convey any technical considerations that might affect their installation plans before applying these general guidelines.

The following general rules apply to gaseous fuel system piping:

▲ WARNING Propane and Natural Gas are extremely flammable and explosive, which could cause burns, fire or explosion resulting in death or serious injury.

- Before placing the generator into service, the fuel system lines must be properly purged and leak tested.
- No leakage is permitted.

NOTICE The supplied flexible steel fuel line is not to be installed underground or in contact with the ground.

- The entire flexible steel fuel line must be visible for periodic inspection and must not be concealed within nor contact nor run through any wall, floor, or partition.
- The piping should be of a material that conforms to federal and local codes, rigidly mounted and protected against vibration.
- Piping should be protected from physical damage where it passes through flower beds, shrub beds, and other cultivated areas where damage could occur.

NOTICE The illustration is representative of a typical installation. Your installation may differ.

- Install the flexible steel fuel line **(B)** (supplied) between the generator fuel inlet port **(A)** and rigid piping to prevent thermal expansion, contraction, or any standby movement from causing excessive stress on the piping material.

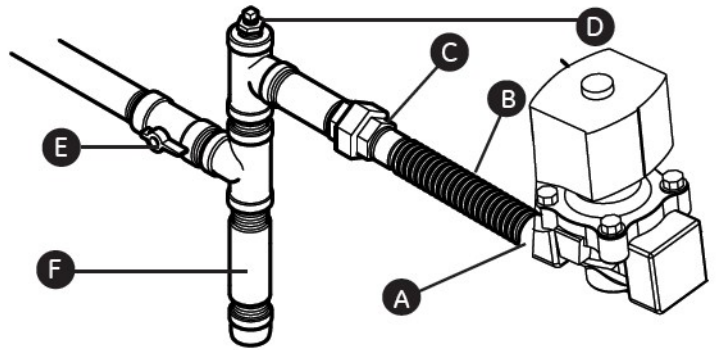

- A union **(C)** or flanged connection shall be provided downstream to permit removal of standby.
- A manometer port should be provided **(D)**. A digital manometer, P/N 19495, is available at your Briggs & Stratton service center. When the initial test runs are completed, the manometer is removed and the port is plugged. The manometer port permits temporary installation of a manometer to ensure that the engine receives the correct fuel pressure to operate efficiently throughout its operating range.
- Where the formation of hydrates or ice is known to occur, piping should be protected against freezing. The termination of hard piping should include a sediment trap **(F)** where condensate is not likely to freeze.
- A minimum of one accessible, approved manual shutoff valve **(E)** shall be installed in the fuel supply line within 6 ft. (180 cm) of the home generator.
- A manual fuel shut-off valve should be installed in the interior of the building.
- Where local conditions include earthquake, tornado, unstable ground, or flood hazards, special consideration shall be given to increase strength and flexibility of piping supports and connections.
- Piping must be of the correct size to maintain the required supply pressures and volume flow under varying generator load conditions with all gas appliances connected to the fuel system turned on and operating.
- Use a pipe sealant or joint compound approved for use with NG/LPG on all threaded fittings to reduce the possibility of leakage.
- Installed piping must be properly purged and leak tested, in accordance with applicable codes and standards.

Fuel Factors

An important consideration affecting the entire installation is the type of fuel used by your generator. The system was factory tested and adjusted using natural gas, but can be converted to use LP vapor. For proper engine function, factors that are inherent to each of these fuels, your location and the duration of possible utility interruptions are important considerations in the following fuel guidelines:

- Use clean, dry fuel, free of moisture or any particulate material. Using fuels outside the following recommended values may cause performance problems.
- In engines set up to run on propane (LP), commercial grade HD5 propane with a minimum fuel energy of 2500 BTUs/ft³ with maximum propylene content of 5% and butane and heavier gas content of 2.5% and minimum propane content of 90% is required.

Natural gas rating will depend on specific fuel but typical derates are between 10 to 20% off the LP gas rating.

Natural gas or LP engines are certified to operate on natural or liquid propane gas. The emissions control system for this engine is EM (Engine Modifications).

 **WARNING** Propane and Natural Gas are extremely flammable and explosive, which could cause burns, fire or explosion resulting in death or serious injury.

- The residential generator is equipped with an automatic safety gas “fuel shut-off” valve.
- DO NOT operate the equipment if the “fuel shut-off” valve is missing or inoperative.

Fuel Pressure

Both LP vapor and natural gas fuel supply pressure at the generator’s fuel inlet port should be between the following levels at full load with all gas appliances turned on and operating.

- NG is 3.5-7” W.C.
- LP is 11-14” W.C.

Ensure that all gas line shutoff valves are OPEN and that adequate fuel pressure is available whenever automatic operation is desired.

Power Loss

Air density is less at high altitudes, resulting in less available engine power. Specifically, engine power will decrease 3.5% for each 1,000 feet (300 m) above sea level and 1% for each 10° F (5.6°C) above 77°F (25°C). Generators located in these conditions must have their transfer switch adjusted appropriately for this power decrease. See Automatic Transfer Switch manual on how to adjust for the power decrease.

Fuel Pipe Sizing

There are numerous on-line or otherwise-published references for fuel pipe sizing. For example, NFPA 54 - National Fuel Gas Code, 2006 (Item #: 320-6031-06) is a common resource.

The installer should consider the specific gravity of gas and compensate for a nominal amount of restriction from bends, fittings, etc. If an unusual number of fittings, bends, or other restrictions are used, refer to federal and local codes for guidance.

Fuel Conversion

The engine of your home generator system is factory Calibrated and set to operate on natural gas (NG). It may also be operated on liquefied petroleum (LP) vapor.

To configure 12 kW units with factory installed fuel harness for LP use:

1. Press control panel "OFF" button.
2. Remove 15 Amp fuse from control panel.
3. Remove Roof.
4. Using a slotted screwdriver turn both **C** and **D** screws clockwise until it is snug (Over tightening can damage mixer port)
5. Using screwdriver turn screw **C** counter clockwise 1 and ½ turns.
6. Leave screw **D** seated.
7. Connect the fuel harness **A** to the engine solenoid **B** by joining the two-pin electrical connectors.
8. Reinstall 15 Amp fuse in control panel.
9. Press control panel "AUTO" button.
10. Reinstall Roof and Close access panels.

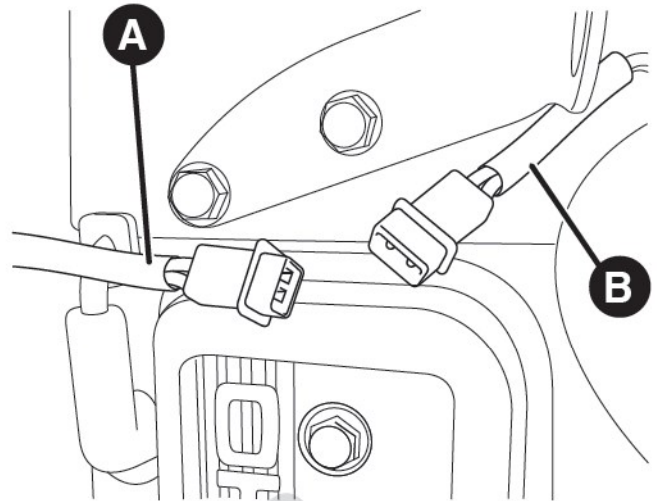

The system is now ready to operate automatically using LP vapor fuel.

To configure 12 kW units without factory installed fuel harness for LP use:

1. Press control panel "OFF" button.
2. Remove 15 Amp fuse from control panel.
3. Remove Roof.
4. Using a slotted screwdriver turn both **C** and **D** screws clockwise until it is snug (Over tightening can damage mixer port)
5. Using screwdriver turn screw **C** counter clockwise 1 and ½ turns.
6. Leave screw **D** seated.
7. Reinstall 15 Amp fuse in control panel.
8. Press control panel "AUTO" button.
9. Reinstall Roof and Close access panels.

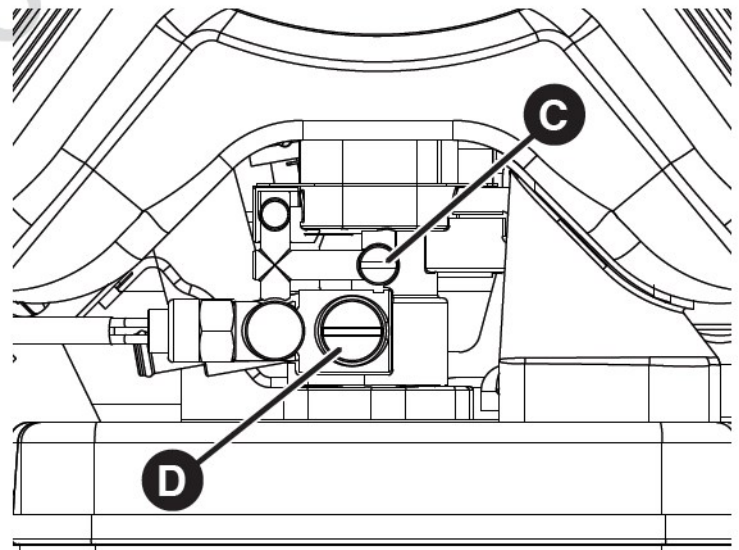

Fuel Consumption

Estimated fuel supply requirements at half and full load for natural gas and LP vapor fuels are shown here.

LP Vapor (Propane)

		12 kW
Full Load	Cu Ft/Hr	83.3
	Gal/Hr (liquid)	2.3
	BTU/Hr	209,000
1/2 Load	Cu Ft/Hr	61.8
	Gal/Hr (liquid)	1.7
	BTU/Hr	155,000
Exercise	Cu Ft/Hr	22.6
	Gal/Hr (liquid)	0.6
	BTU/Hr	57,000

Recommended Energy Content of Fuel:	Natural Gas	Propane (LP Vapor)
Heating Value:		
BTU per gallon liquid (gross*)	N/A	91,547
BTU per Cubic feet (vapor)	1,000	2,500

Natural Gas

		12 kW
Full Load	Cu Ft/ Hr	171.6
	BTU / Hr	172,000
1/2 Load	Cu Ft/ Hr	116.9
	BTU / Hr	117,000
Exercise	Cu Ft/ Hr	66
	BTU / Hr	66,000

Not for
Reproduction

System Connectors

Low Voltage connections to signal fault contacts, transfer switch communication and auxiliary 12VDC power are made via a field connection terminal block in control board area. Compare this illustration with your generator to familiarize yourself with the location of these connections.

- A - Two Pin Terminal Block** — Used to connect utility 240 VAC from fuse block in ATS to the control board. Connect only one wire per terminal. Use #14 [2.5mm²] AWG minimum 300 volt wire.
- B - Fault Contacts** — Use 1 (N.O.), 2 (COM) and 3 (N.C.) to hook up a siren, light, etc. to alert you in case of a fault. Contacts reverse state (1 [N.O.] goes to 3 [N.C.] and vice versa) upon a fault condition.
- C - Transfer Switch Communication (4 [TxRx] and 5 [TxRx GND])** — Connect to transfer switch control board for communication interface using 18AWG [1mm²] twisted pair wire.
- D - 6 (+LED) and 7 (GND) Connection** — Not required for wireless monitor included with unit. Available for optional hardwired remote system status panel accessory, #6154.
- E - Eight Pin Terminal Block** — Used to connect signal wires to the control board. Connect only one wire per terminal.
- F - Power Connection (Line 1 and Line 2)** — Power connection to transfer switch.
- G - Neutral and Ground Connection** — Connect to transfer switch neutral and ground

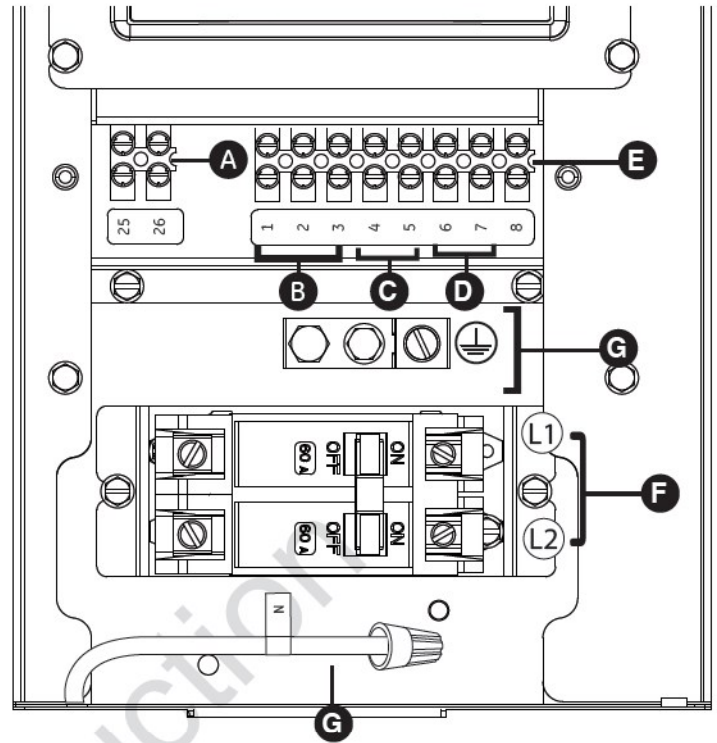

- For power output connection (Line 1, Line 2, Neutral, and Ground), refer to the following table:

≥ 300V, 75° C	12 kW
	8AWG [8mm ²] min. Cu
	6AWG [13mm ²] min. Al

* Reference NEC 2014 table 310.15 • Use National Electric Code for correction factors and wire size calculations.

- For transfer switch communication use #18 AWG [1mm²] twisted pair conductors, no greater than 200 ft in length, 300 volt wire.
- When connecting to the terminal block, fasten only one wire to each connector screw.
- Torque terminal block screws to 4.4 in-lb [0.49 Newton meter].
- Torque circuit breaker connections to 45 in-lb [5 Newton meter].

* Metric system rounded for simplicity

Communication Connections

Connect the applicable communication leads to the automatic transfer switch as shown in the table below.

Pin Number	Description	Wire Type	Connect To	Notes
1	Normally Open	18 AWG [1 mm ²] twisted pair conductors no longer than 61 m, 300V, 90°C copper wire		For Optional Alarm
2	Common	18 AWG [1 mm ²] twisted pair conductors no longer than 61 m, 300V, 90°C copper wire		For Optional Alarm
3	Normally Closed	18 AWG [1 mm ²] twisted pair conductors no longer than 61 m, 300V, 90°C copper wire		For Optional Alarm
4	Transfer Switch Communication	18 AWG [1 mm ²] twisted pair conductors no longer than 61 m, 300V, 90°C copper wire	4 (T/R) on transfer switch board	Must Connect
5	Transfer Switch Communication Ground	18 AWG [1 mm ²] twisted pair conductors no longer than 61 m, 300V, 90°C copper wire	5 (GND) Ground on transfer switch board	Must Connect
6	+LED	18 AWG [1 mm ²] twisted pair conductors no longer than 61 m, 300V, 90°C copper wire	Red wire on fault indicator plate	For Optional Fault Indication
7	Ground	18 AWG [1 mm ²] twisted pair conductors no longer than 61 m, 300V, 90°C copper wire	Black wire on fault indicator plate	For Optional Fault Indication
8	Not Used	N/A	N/A	N/A
25	Utility	14 AWG [2.5 mm ²] minimum 300v wire	Transfer Switch Utility	Must Connect
26	Utility	14 AWG [2.5 mm ²] minimum 300v wire	Transfer Switch Utility	Must Connect

* Metric system rounded for simplicity

Generator AC Connection System

A single-phase, three-wire AC connection system is used in the home generator. The stator assembly consists of a pair of stationary windings with two leads brought out of each winding. The junction of leads 22 and 33 forms the neutral lead, as shown schematically and as a wiring diagram. A complete schematic and wiring diagram can be found later in this manual.

NOTICE Neutral is not bonded to ground at generator.

NOTICE Generator must be used with only a UL approved transfer switch that is compatible with the generator.

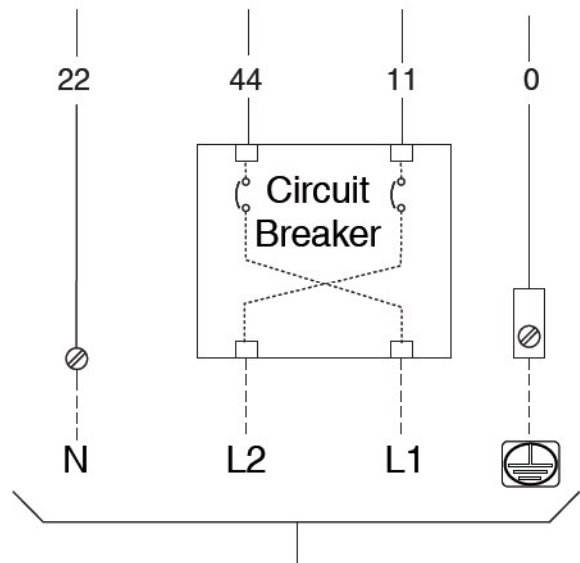
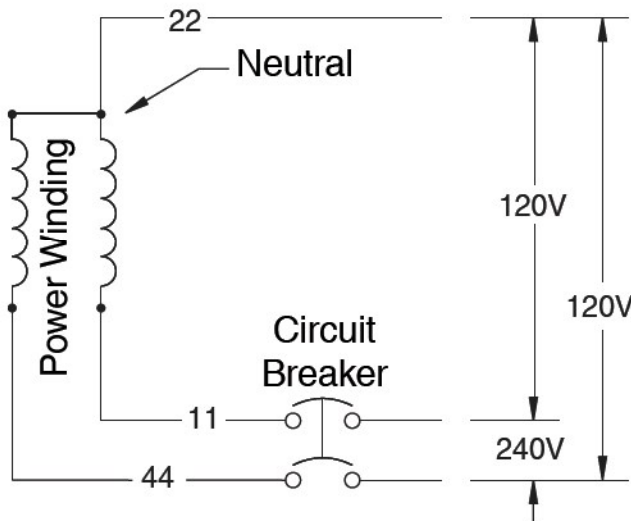

Grounding the Generator

The home generator must be installed as part of a system that includes a listed transfer switch, with neutral to ground bonding at the transfer switch in accordance with installation instructions. Unless mandated by local code, additional grounding to earth at the generator is

not required. Any grounding at generator must use metal piercing lock washers (or equal), UL listed terminals installed per terminal supplier's instructions, and comply with national electrical codes and local requirements.

Power Connections from Generator to Transfer Switch

Utility Circuit Connection

"240V Utility" leads must be routed in conduit. The "240V Utility" leads deliver power to the generator's circuit board, optional battery warmer and optional oil warmer. This power also charges the battery. When power on these leads is lost, the generator will start.

Using installer-supplied minimum 300V, 14 [2.5 mm²] AWG wire, connect each control circuit terminal in the generator (25 and 26) to the fuse block in the automatic transfer switch.

Reference illustration on page 25 for further information.

Generator Power Connection

For 12kW Units: Using installer supplied minimum 300V, wires and the table located on page 25, connect generator power output Line 1, Line 2, neutral, and ground to the corresponding Line 1, Line 2, neutral and ground in the transfer switch.

**Use National Electric Code for correction factors and wire size calculations.*

Transfer Switch Communication

Using installer supplied #18 AWG [1 mm²] twisted pair conductors, no greater than 200 ft in length, connect 4 (TxRx) and 5 (TxRx GND) from the generator terminal block **A** to 4 (T/R) and 5 (GND) on the transfer switch control board **B**.

When making connections, obey wire type and torque specifications printed on the circuit breaker and neutral/ground connectors.

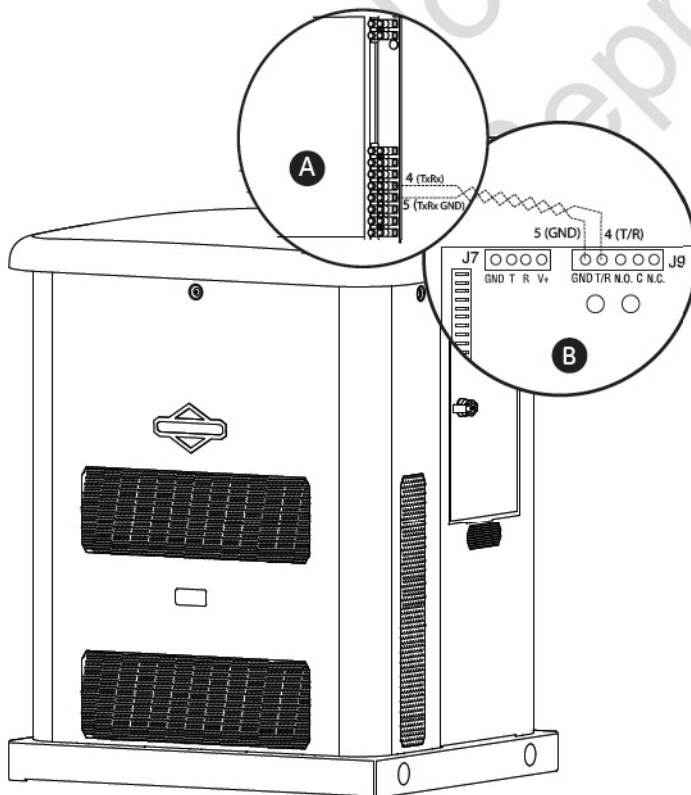

System Control Board

The generator control board, located inside the generator, under the roof, is shown below. Brief descriptions of the controls used during installation are:

A - **Menu/Programming Navigation Buttons** — See *Menu* section for details

B - **USB Port** — Authorized Dealer Service Use Only

C - **Generator Operation Control Buttons** —

- “**AUTO**” Normal operating position. Press and hold button to put unit into Automatic mode. If an utility power outage is sensed, the system will start the generator. When utility power is restored, auto lets the engine stabilize internal temperatures, shuts off the generator, and waits for the next utility outage.

- “**OFF**” Turns off running generator, prevents unit from starting, and resets any detected faults.

OFF must be pressed and held for more than 5 seconds in order to reset service codes.

- “**MANUAL**” Used to manually start the generator.

- * - “**AUTO**” **LED** — LED will light when unit is placed into Auto mode. LED will blink if exercise cycle is not set or set to OFF.

- D** - **15 Amp Fuse** — Protects the home generator DC control circuits. If the fuse has ‘blown’ (melted open) or was removed, the engine cannot crank or start. Replace the fuse using only an identical ATO 15A fuse. One spare fuse is supplied with the unit.

- E** - **Cover** — This protective cover must be opened to access the fuse and the USB port.





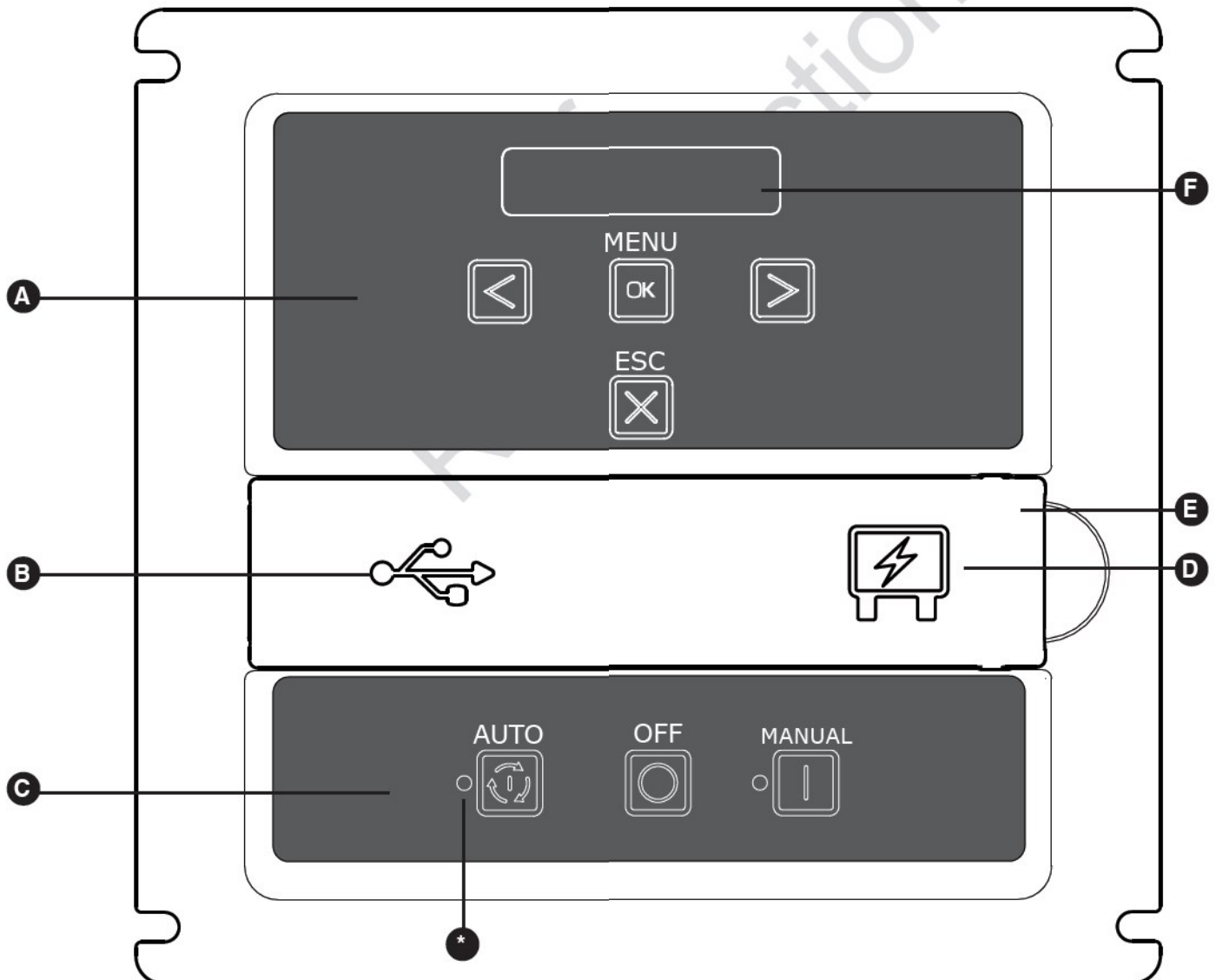

- F** - **Digital Display** — Displays generator mode, menu options, service codes, and service engine indicators

More information may be found in *Controls* in the operator’s manual.





Menu



The following chart shows the icons for the buttons that control the system control panel.

	MENU	ENTER THE MENU (VIEW SETTINGS) PRESS TO CONFIRM SELECTION WHEN PROGRAMMING.
	ESCAPE (EXIT)	RETURN TO LAST MENU ITEM
	RIGHT ARROW	TOGGLE THROUGH MENU OPTIONS SETTING SYSTEM PARAMETERS
	LEFT ARROW	TOGGLE THROUGH MENU OPTIONS SETTING SYSTEM PARAMETERS
	MANUAL MODE	USED TO MANUALLY START THE GENERATOR. PRESS AND HOLD BUT- TON TO START THE GENERATOR.
	OFF	TURNS OFF RUNNING GENERATOR, PREVENTS UNIT FROM STARTING, AND RESETS ANY DETECTED FAULTS.
	AUTOMATIC MODE	NORMAL OPERATING POSITION. PRESS AND HOLD BUTTON TO PUT UNIT INTO AUTOMATIC MODE. IF A UTILITY POWER OUTAGE IS SENSED, THE SYSTEM WILL START THE GENERATOR. WHEN UTILITY POWER IS RE- STORED, AUTO LETS THE ENGINE STABILIZE INTERNAL TEMPERATURES, SHUTS OFF THE GENERATOR, AND WAITS FOR THE NEXT UTILITY POW- ER OUTAGE.

The following chart describes key sequences for accessing different programming modes;

	GENERAL SET-UP	PRESS AND HOLD [ARROW LEFT AND ARROW RIGHT] UNTIL "GENERAL SET-UP" IS DISPLAYED TO ENTER THE PROGRAM MODE.
	ADVANCED SETTINGS	PRESS AND HOLD [ARROW LEFT, ARROW RIGHT AND ESC] UNTIL "ADVANCED SETTINGS" IS DISPLAYED OR PRESS AND HOLD EITHER [ARROW LEFT, ARROW RIGHT OR ESC] BUTTON UNTIL "++1++" IS DISPLAYED ON THE DIGITAL DISPLAY. NEXT PRESS AND HOLD A DIFFERENT KEY [ARROW LEFT, ARROW RIGHT OR ESC] BUTTON UNTIL "++2++" IS DISPLAYED. FINALLY, PRESS AND HOLD THE REMAINING BUTTON NOT SELECTED [ARROW LEFT, ARROW RIGHT OR ESC] UNTIL "ADVANCED SETTINGS" IS DISPLAYED.
	WIRELESS LINK MODE	PRESS AND HOLD [MENU AND ESC] FOR THREE SEC- ONDS TO ENTER THE WIRELESS LINKING MODE. (ONLY APPLICABLE ON SOME MODELS).

General Set Up Screen

For general set up, press and hold the left arrow and right arrow   until "General Set-Up" is displayed. Follow the prompts as outlined below.

NOTE: Date and Time were set at the factory and stored in the control panel memory. The Exercise Cycle was also set at the factory. The default exercise cycle occurs on Tuesdays, at 2:00 P.M. Central Standard Time. To updated or change these settings, follow the steps below.

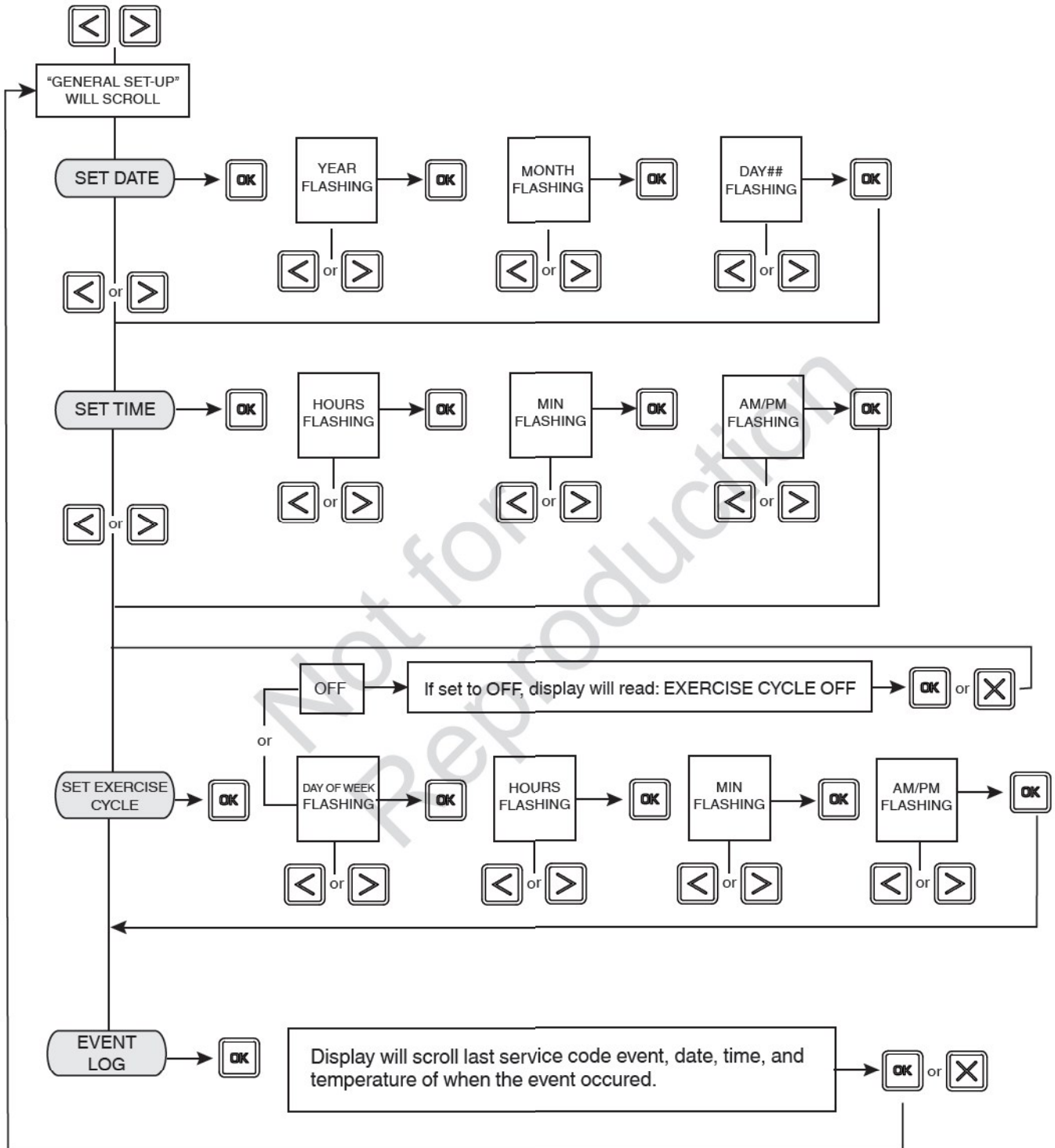

IF DURING PROGRAMMING NO BUTTONS ARE PRESSED FOR 40 SECONDS, THE CONTROL PANEL WILL AUTOMATICALLY EXIT THE PROGRAM MODE.

Control Panel Prompts

Automatic Mode

In Automatic Mode, the display screen will display via scrolling text:

- GENERATOR READY - if the unit is in standby and utility power is present.
- GENERATOR ON - if the unit is running and utility power is not present.
- SERVICE CODE - if a system fault has been detected.

General System Parameters

To view general system parameters, press the MENU button.

The following will scroll across the digital display and then move to the next item:

- Run time
- Date
- Time
- Exercise Cycle date and start time
- Software Version

The user can press the LEFT ARROW or RIGHT ARROW at any time to move to the next item.

The user can press ESCAPE to go back to GENERATOR READY.

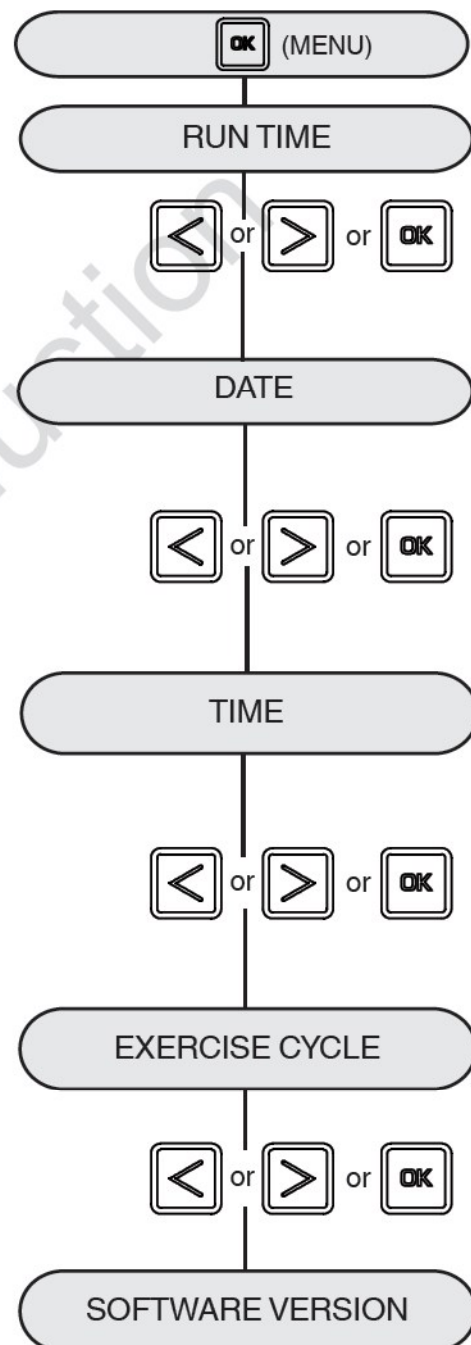
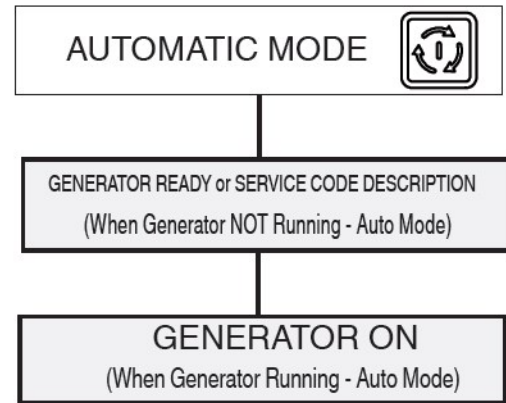

If no user inputs are made for 40 seconds after all the items have been displayed, the control board digital scrolling display will reset to previous scrolling display.





Advanced Settings Screen

Advanced setting parameters are preset at the factory for a typical installation. To view Advanced Settings items and/or to change items, follow the instructions listed below.

NOTICE Advanced settings are critical to the operation of the unit. Careful consideration should be taken when working in the Advanced Settings menu. Exercise caution when selecting and verifying parameters for the generator and region where the generator is being operated. Confirm all settings before operating the generator for the first time.

For advanced menu items, press and hold the left arrow, right arrow, and escape key    for 3 seconds or see pg. 29 for additional key sequence. Follow the prompts as outlined below.

NOTICE In the Advanced Setting menu, a three button access code (left arrow, right arrow, and escape key   ) must be pressed once to enter the menu and again to change any setting. After each confirmation of a setting, the selection will display solid for 2 seconds before moving to the next program item.

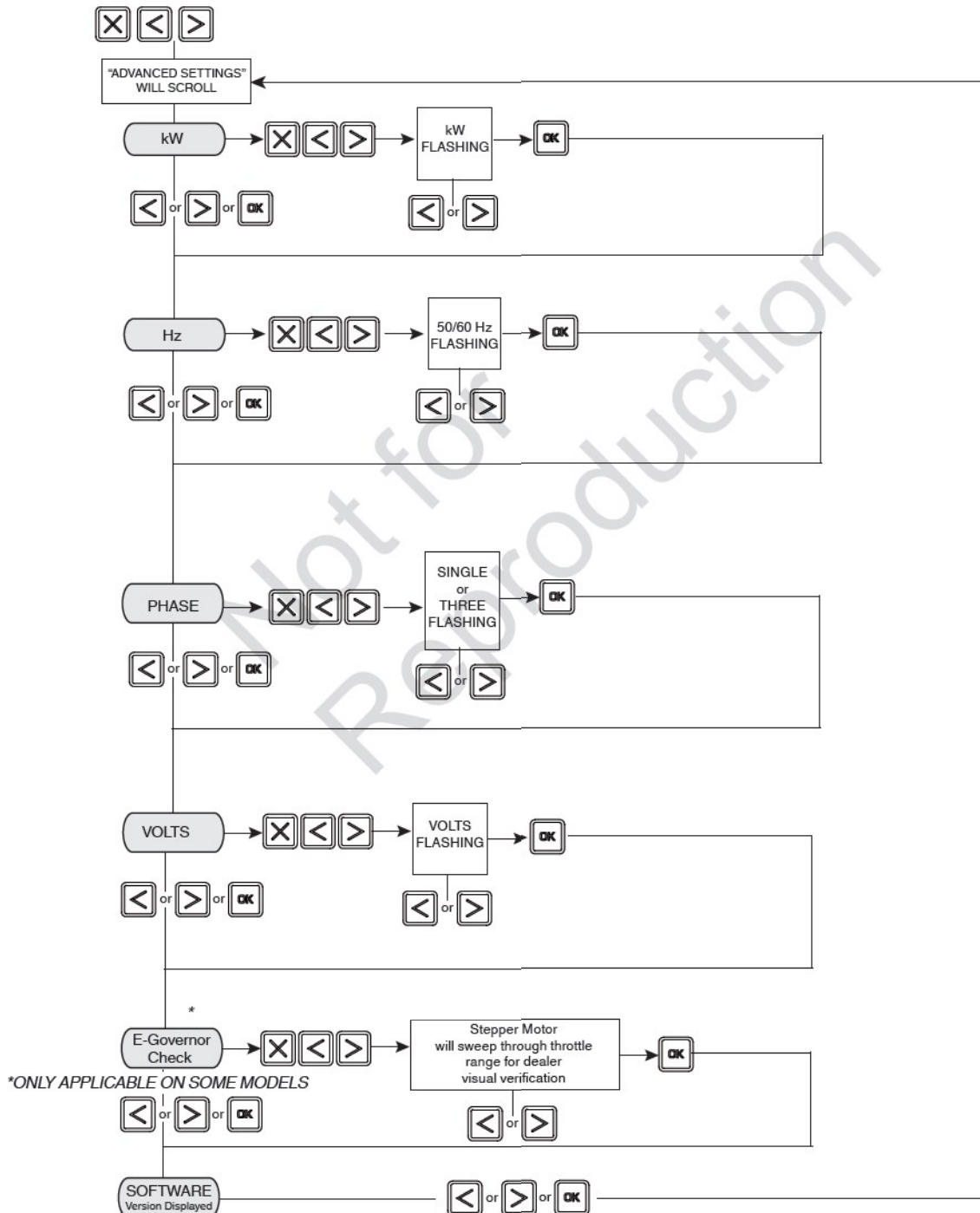

Service Code Detection System

The generator may have to run for long periods of time with no operator present. For that reason, the system is equipped with sensors that automatically shut down the generator in the event of potentially damaging conditions, such as low oil pressure, high temperature, over speed, and other conditions.

Refer to *Service Code Detection System* in the operator's manual for more detailed information.

Final Installation Considerations

Engine Oil

NOTICE Any attempt to crank or start the engine before it has been properly serviced with the recommended oil will result in possible equipment failure and service codes.

- Refer to *Maintenance* in the operator's manual for oil fill information.
- Damage to equipment resulting from failure to follow this instruction will void engine and generator warranty.

This engine is shipped from the factory pre-run and filled with synthetic oil (API SJ/CF 5W-30). This allows for system operation in a wide range of temperature and climate conditions. Before starting the engine, check oil level as described in *Maintenance* of the Operator's Manual.

The use of synthetic oil does not alter the required oil change intervals described in the Operator's Manual.

For operation of temperatures below 30°F (-1°C), the use of fully synthetic oil (minimum API SJ) of viscosity 5W30 is required.

Battery

The installer must supply and install a rechargeable 12 volt starting battery. The starting battery **MUST** conform to the specifications shown in this chart.

Battery Specifications		
Specifications	Standard	Cold Start (less than 30°)
Volts	12 Volt DC	12 Volt DC
Amps (MIN)	540 CCA (cold cranking amps)	800 CCA (cold cranking amps)
Construction	Wet lead acid	Wet lead acid
Terminal Type	Top post type battery	Top post type battery
Dimensions (MAX):	BCI size 26 or BCI size 51	BCI size 24

Install the battery as described in *Servicing the Battery* in the *Maintenance* section of the operator's manual. Always make sure the **NEGATIVE** cable is connected last and that the red **POSITIVE** terminal insulator is fully in place.

▲ WARNING Storage batteries give off explosive hydrogen gas during recharging.



Slightest spark will ignite hydrogen and cause explosion, resulting in death or serious injury.

Battery electrolyte fluid contains acid and is extremely caustic. Contact with battery contents could cause severe chemical burns.

A battery presents a risk of electrical shock and high short circuit current.

- DO NOT dispose of battery in a fire. Recycle battery.
- DO NOT allow any open flame, spark, heat, or lit cigarette during and for several minutes after charging a battery.
- DO NOT open or mutilate the battery.
- Wear protective goggles, rubber apron, rubber boots and rubber gloves.
- Remove watches, rings, or other metal objects.
- Use tools having insulated handles.

▲ WARNING Battery posts, terminals and related accessories contain lead and lead compounds, chemicals known to the State of California to cause cancer and reproductive harm. Wash hands after handling.

Use the supplied tie-down strap **A** to secure the battery to the unit. Each end of the strap should be attached to the existing tabs in the base of the unit.

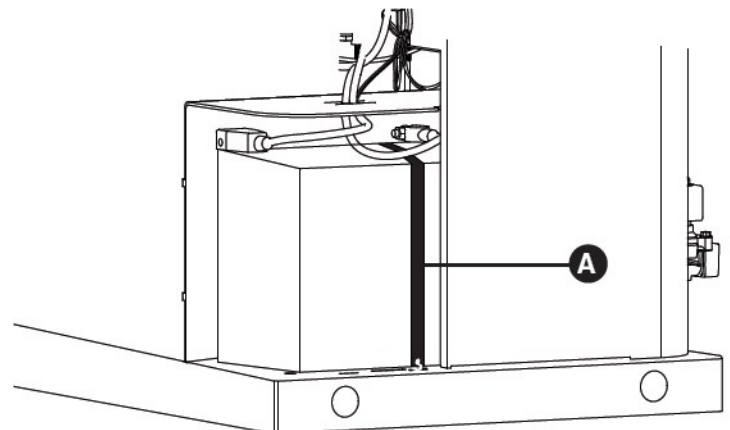

Initial Start-up (No Load)

The unit has been set-up for NG operation at the factory. Fuel conversion, if needed, must be completed prior to performing these steps. See *Fuel Conversion*.

Before operating the home generator or placing it into service, inspect the entire installation carefully. Then begin testing the system without any electrical loads connected, as follows:

1. Remove two screws **A** that secure circuit breaker cover to expose unit's circuit breaker.

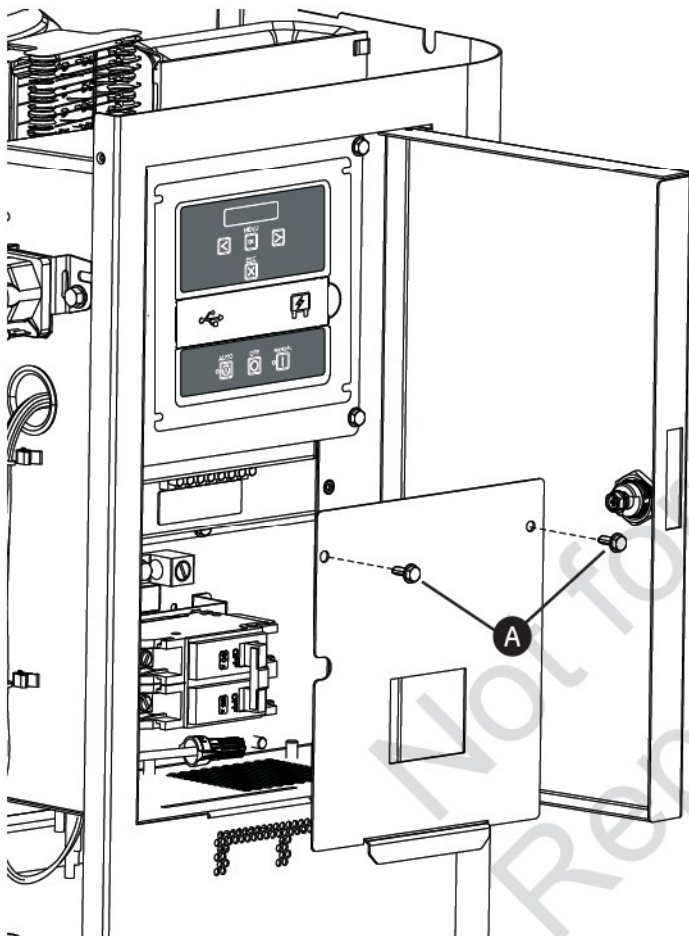

2. Connect an accurate frequency meter to line side of generator's main circuit breaker.
3. Set generator's main circuit breaker to **ON** (closed) position.
4. Install 15 Amp fuse in control board.
5. Press and hold **MANUAL** button on control board for 3 seconds. Engine will start.

When the generator is started for the very first time, it will require that air in the gaseous fuel lines be purged. This may cause the engine to run roughly for a few minutes.

6. Listen for unusual noises, vibration or other indications of abnormal operation. Check for oil leaks while engine runs.
7. Let engine warm up for about 5 minutes to allow internal temperatures to stabilize.
8. Check generator output at load side of circuit breaker. Voltage should be 225 - 250 Volts, frequency should be 59 - 61 Hz.
9. Check generator output between one generator connection lug and neutral lug, then between other generator connection lug and neutral lug. In both cases, voltage reading should be between 112 and 125 Volts.
10. Push and hold **OFF BUTTON** on control board until engine stops.
11. Reinstall circuit breaker cover.

CAUTION Installing the 15A fuse could cause the engine to start at any time without warning resulting in minor or moderate injury.

- Observe that the 15 Amp fuse has been removed from the control panel for shipping.
- **DO NOT** install this fuse until all plumbing and wiring has been completed and inspected.

Operation

Automatic Operation Sequence

The generator's control board constantly monitors utility voltage. Should utility voltage drop below a preset level, the control board will signal the engine to crank and start.

When utility voltage is restored above a preset voltage level, the engine is signaled to shut down.

The actual system operation is not adjustable and is sequenced by sensors and timers on the control board, as follows:

Utility Voltage Dropout Sensor

- This sensor monitors utility source voltage.
- If utility source voltage drops below about 70 percent of the nominal supply voltage, the sensor energizes a 3 second timer. The timer is used to 'sense' brown-outs.
- Once the timer has expired, the engine will crank and start.

Setting Exercise Timer

The generator is equipped with an exercise timer. During the exercise period, the unit runs for approximately 20 minutes and then shuts down. Electrical load transfer DOES NOT occur during the exercise cycle (unless an utility power outage occurs).

The generator will only enter the exercise cycle if the unit is in the AUTO mode and this exact procedure is followed.

To set the exercise timer:

NOTICE The generator is set with a default exercise cycle setting of Tuesday at 2:00 P.M, Central Time. To change the cycle setting, proceed to the following steps:

1. Choose the day and time you want your generator to exercise.
2. Press and hold the left arrow until "General Set-Up" scrolls. See *General Set-Up* flow chart in Menu Section.
3. Verify and/or set the time and date on the unit.
4. Go to the SET EXERCISE prompt and hit the "OK" button.

NOTICE Items will flash until they are selected.

Utility Voltage Pickup Sensor

This sensor monitors utility power voltage. When utility voltage is restored above 80 percent of the nominal source voltage, a time delay starts timing and the engine will go to engine cool-down.

Engine Cool-down Timer

When utility power is sensed and the load transfers to the utility source, the engine will go into a cool down period as described below:

- If the generator has run for MORE than 5 minutes, once the utility transfer occurs, the engine will continue to run for about 1 minute before shutting down.
- If the generator has run for LESS than 5 minutes, once the utility transfer occurs, the engine will continue to run until 5 minutes has elapsed before shutting down.

SELECT DAY: Use the left or right arrow to toggle through the days of the week. Once the day is selected, hit the "OK" button.

SELECT HOUR: Use the left or right arrow to toggle through between 1 and 12. Choose the hour of day you want the generator to exercise then hit the "OK" button.

SELECT MINUTE: Use the left or right arrow to toggle between :00 and :59. Choose the minute of the day you want the generator to exercise then hit the "OK" button.

SELECT AM/PM: Use the left or right arrow to toggle between AM and PM. Once chosen, hit the "OK" button.

NOTICE During the weekly exercise cycle, the generator will run for 20 minutes, but it will not supply power to the home. During the exercise cycle, the in-home monitor will continue blinking the GENERATOR READY green LED.

If you want to change the day and time the unit exercises, simply perform the procedure again.

To turn off the generator exercise cycle, go to the OFF selection within the day of the week menu and press OK. The display will then scroll: EXERCISE CYCLE OFF.

Optional Wireless Monitor (Sold Separately)

The generator is supplied with a battery-powered, wireless monitor.

The monitor communicates wirelessly with the generator control panel. The monitor may be placed in a suitable location in the home. The system has a line-of-sight range of about 200 feet, but this distance will decrease if the signal has to pass through walls or other objects.

The wireless monitor communicates with the generator, every 10 minutes and will display the status via a green or red LED light on the front of the monitor.

Compare the illustration below with your monitor to familiarize yourself with these important components.

- Generator Ready **A** - Green LED
- Generator Power **B** - Green LED
- Service Needed **C** - Red LED
- System Update **D** - Press for current system update with generator.
- Service code descriptions **E** - Name and number of flashes are listed on the backside of the wireless monitor.
- Battery Access Cover **F** - Record the dealer name and phone number on the label provided. Once removed, two non-rechargeable AA batteries are installed in the compartment **G**.

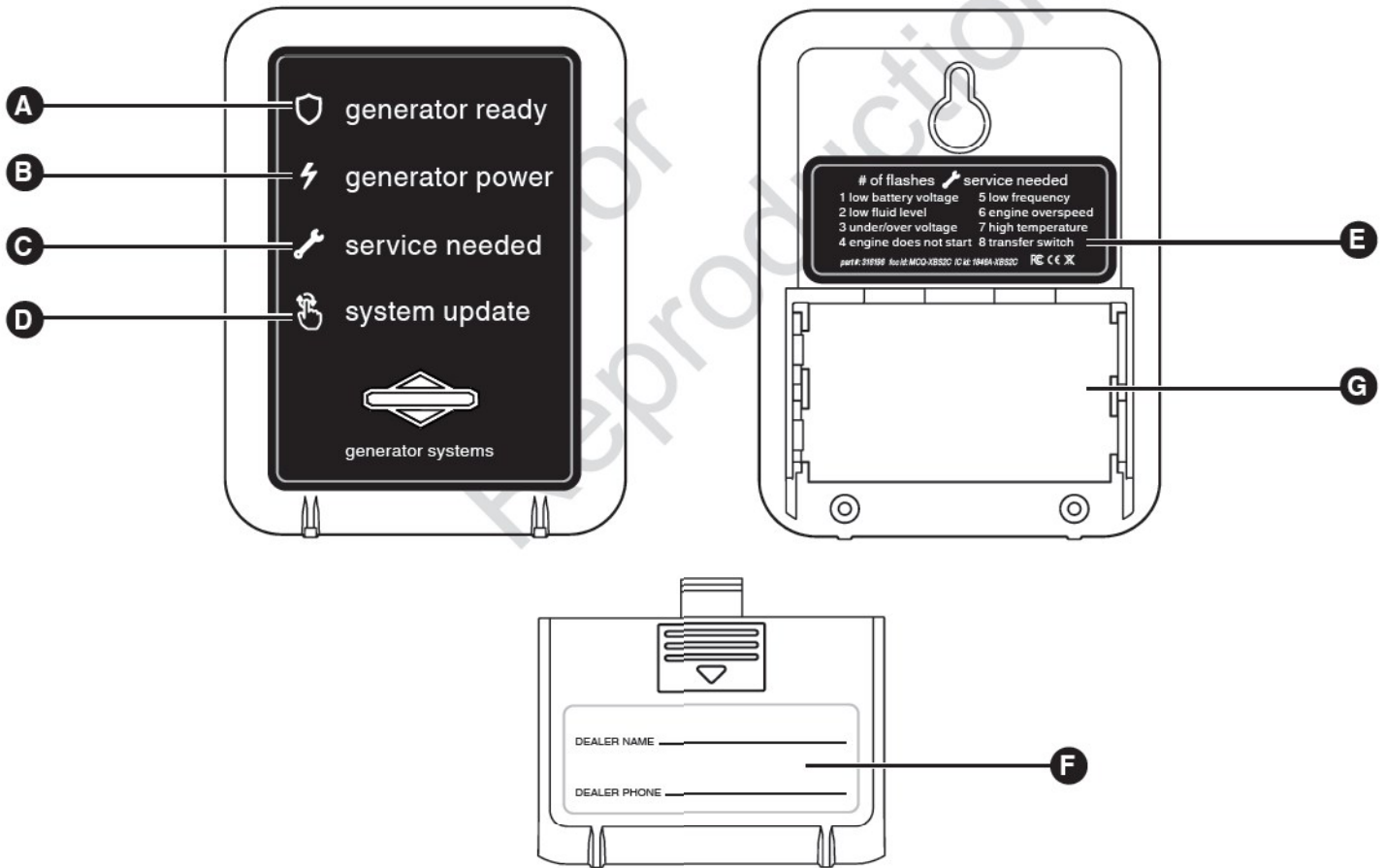

Antenna Placement

The wireless monitor includes an antenna that was installed at the factory.

Before shipping, the magnetic-backed antenna was moved to the side of the generator to prevent damage **A**.

Before starting the wireless monitor, mount the antenna on the top of the unit **B**.

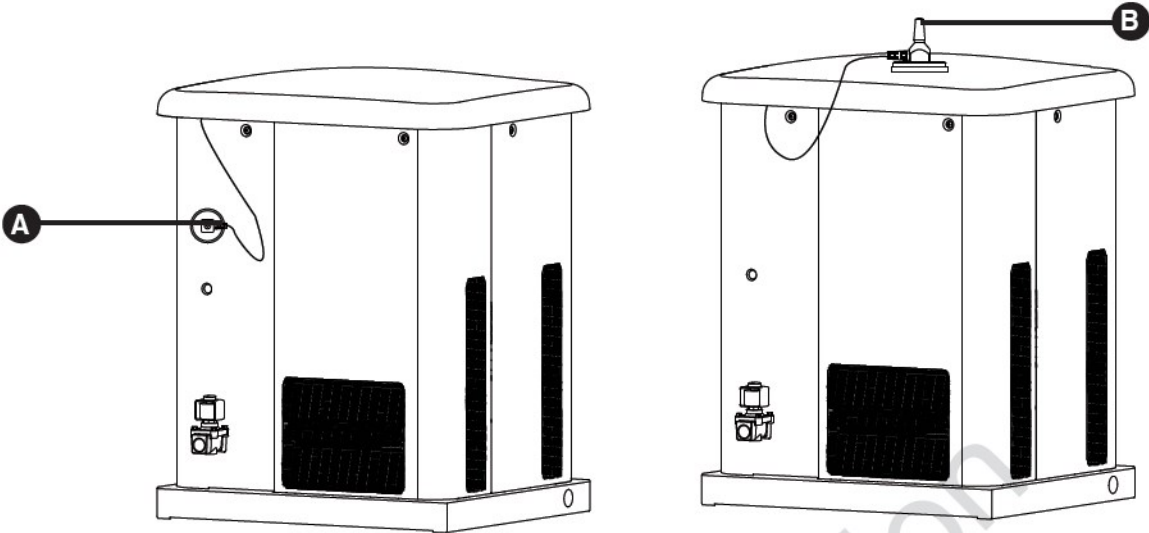

Wireless Monitor Operation

1. Remove battery access cover **C** on back of monitor and install 2 AA batteries. (Observe correct battery polarity which is embossed in the bottom of the battery compartment). Replace battery access cover.
2. The wireless monitor does not have an on/off switch. When batteries are installed correctly and the generator is in auto mode, the GENERATOR READY green LED light will flash once every 7 seconds indicating the status of the generator.

NOTICE If communication does not begin upon placing the generator in AUTO, installing batteries, and pressing

NOTICE The wireless monitor was linked to the generator at the factory. Communication will begin upon the installation of the batteries and the generator being placed in AUTO mode. You may need to press System Update one time.

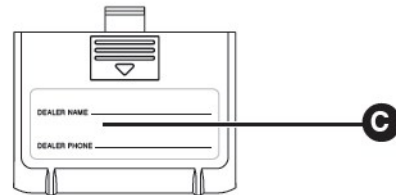
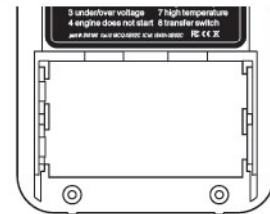

System Update, please refer to LED Lighting Codes on page 39. To link, follow Steps 3 through 6.

Linking the Wireless monitor:

1. Locate the MENU AND ESCAPE buttons on the control panel **A**. Press and hold for about 3 seconds to enter the linking mode.
2. "LINKING MODE" will scroll across the generator control panel.
3. Locate and hold the SYSTEM UPDATE button **B** on the wireless monitor for 5 seconds while installing the batteries until all 3 LEDs turn on solid. All 3 LEDs will stay on solid until the monitor links to the generator. Once it links, the monitor will display the current state. The monitor will try to link for 1 minute. (This step can only be completed when the generator is in Linking Mode).
4. Once the link has been confirmed, press the OK button on the generator control panel to exit or the control board will automatically turn off linking after 5 minutes. The generator will now communicate with the wireless monitor.

NOTICE It may take up to 1 minute for the monitor to begin displaying the generator status correctly.

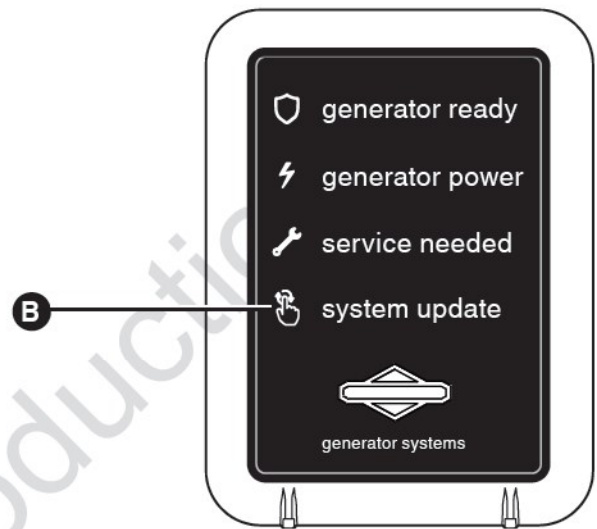
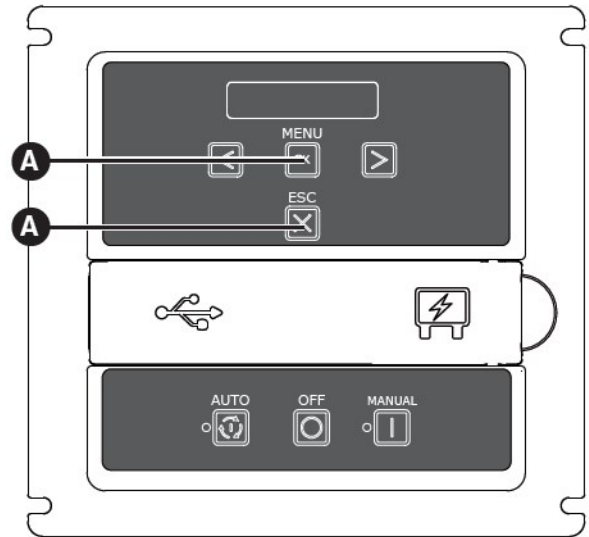

Standard Operation:

Wireless Monitor Status LED's

- The wireless monitor receives data from the generator every 10 minutes and displays the generator status through 3 LED's.
- Pressing the SYSTEM UPDATE button will provide current generator status by flashing the status LED's. When pressed, all 3 LEDs will flash until the generator status is received.

NOTICE Generator control panel must be in AUTO mode or no communication with monitor will occur.

- In order to conserve power and to extend battery life, the LED's are not lit continuously; instead they are briefly flashed as indicated below.

NOTICE During the weekly exercise cycle, the generator will run for 20 minutes, but it will not supply power to the home. During the exercise cycle, the monitor will continue blinking the GENERATOR READY green LED.

- **GENERATOR READY** - When active, the green LED will flash once every 7 seconds. The green LED indicates that the generator is in AUTO mode and that it is ready to run in the event of a loss of utility power.
- **GENERATOR POWER** - When active, the green LED will flash every 7 seconds. The green LED indicates that the generator is supplying power.
- **SERVICE NEEDED** - When active, the red LED will flash in a sequence that corresponds to the service code. For example, when Low Frequency scrolls across the control board, the red LED will flash 5 times with a 3 second pause between series of blinks until it is reset or the condition is corrected. Contact the nearest authorized service dealer if the problem can not be fixed.

NOTICE Service conditions will only be displayed on the basic monitor when the control board is placed in AUTO mode.

Installation Inspection

Before placing the generator system into service, inspect the entire installation carefully, utilizing the Installation Checklist on page 9.

This completes the installation and start-up instructions. The operator's manual provides full details on Operation, Maintenance and Troubleshooting for this generator system.

Other:

LED Lighting Codes

- No status LEDs illuminated - Generator in OFF mode or check and replace batteries.

Wireless communication lost issues can typically be resolved by moving the wireless monitor closer, within the home, to the standby generator. See Optional Router Accessory Kit

- **Batteries Inserted** - the shield LED will light for 5 seconds.
- **Linking Error or Not Linked** - Each LED will light then turn off in one direction, then the other direction until a successful link is completed.
- **During the weekly exercise cycle**, the generator will run for 20 minutes, but it will not supply power to the home. During the exercise cycle, the monitor will continue blinking the green shield LED.

Service Code Descriptions - name and number of flashes are listed on the back side of the wireless monitor.

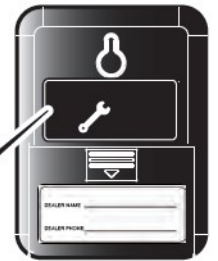

# of flashes  service needed	
1 low battery voltage	5 low frequency
2 low fluid level	6 engine overspeed
3 under/over voltage	7 high temperature
4 engine does not start	8 transfer switch

part #: xxxxx fcc id: xxxxx IC id: 1xxxxx 

None of the service needed codes are cleared at the wireless monitor. All alerts must be cleared at the generator control panel.

Schematic / Wiring Diagrams

Schematic Diagram - 12kW

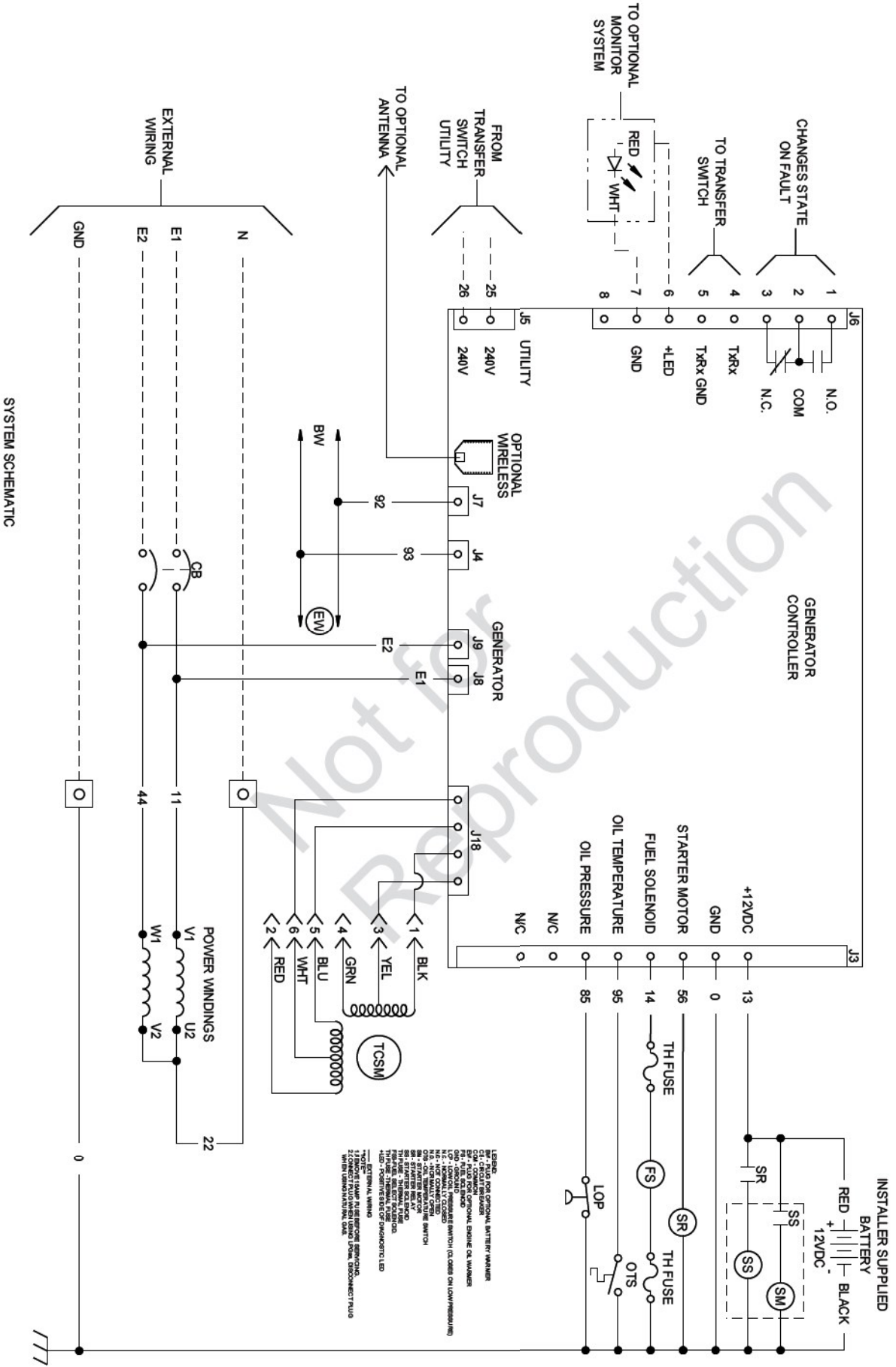

Not for
Reproduction

Not for
Reproduction

Not for
Reproduction

Briggs & Stratton Power Products Group, LLC
P.O. Box 702
Milwaukee, WI 53201-0702

Copyright © 2015. All rights reserved. No part of this material may be reproduced or transmitted in any form without the express written permission of Briggs & Stratton Power Products Group, LLC.