



Installation Manual

Generator Set

QSJ8.9G Engine with PowerCommand® 2.3 Control

C125 N6 (Spec A)

C150 N6 (Spec A)

**CALIFORNIA
Proposition 65**

Warning: Natural Gas/Liquid Propane Gas engine exhaust and some of its constituents are known to the State of California to cause cancer, birth defects, and other reproductive harm.

Table of Contents

1. IMPORTANT SAFETY INSTRUCTIONS	1
1.1 Warning, Caution, and Note Styles Used in This Manual	1
1.2 Save These Instructions	1
1.3 General Information	2
1.4 General Precautions	2
1.5 Generator Set Voltage Is Deadly	6
1.6 Fuel and Fumes Are Flammable	6
1.7 Starting Batteries	7
1.8 Batteries Can Explode	7
1.9 Vented Batteries	8
1.10 Moving Parts Can Cause Severe Personal Injury or Death	9
1.11 Exhaust Gases Are Deadly.....	9
1.12 The Hazards of Carbon Monoxide.....	10
2. INTRODUCTION.....	11
2.1 About This Manual.....	11
2.2 Schedule of Abbreviations	11
2.3 Related Literature	13
2.4 Model Specifications	14
2.5 Before Installation	19
3. PRE-INSTALLATION CONSIDERATIONS.....	21
3.2 Installation Codes and Standards for Safety	22
3.3 Required Items for Installation.....	24
4. INSTALLATION.....	27
4.1 Site Assessment and Preparation	27
4.2 Fuel System Connection.....	31
4.3 Engine Exhaust.....	35
4.4 Electrical Connections	36
5. STARTUP AND CONFIGURATION.....	45
5.1 Operator Panel.....	45
5.2 Checklist	57
5.3 Before Starting.....	59
5.4 Startup	65
APPENDIX A. FUEL LINE SELECTION.....	67
A.0 Fuel System Pipe Sizing Introduction.....	68
A.1 Gas Pipe Sizing.....	69
APPENDIX B. OUTLINE AND SYSTEM DRAWINGS.....	75
APPENDIX C. WIRING DIAGRAMS.....	85

C.0 Wiring Diagrams.....	86
APPENDIX D. SEISMIC REQUIREMENTS.....	101
D.1 Seismic Installation Instructions	103

1 IMPORTANT SAFETY INSTRUCTIONS

SAVE THESE INSTRUCTIONS. This manual contains important instructions that should be followed during installation and maintenance of the generator set and batteries.

Safe and efficient operation can be achieved only if the equipment is properly operated and maintained. Many accidents are caused by failure to follow fundamental rules and precautions.

1.1 Warning, Caution, and Note Styles Used in This Manual

The following safety styles and symbols found throughout this manual indicate potentially hazardous conditions to the operator, service personnel, or equipment.

DANGER

Indicates a hazardous situation that, if not avoided, will result in death or serious injury.

WARNING

Indicates a hazardous situation that, if not avoided, could result in death or serious injury.

CAUTION

Indicates a hazardous situation that, if not avoided, could result in minor or moderate injury.

NOTICE

Indicates information considered important, but not hazard-related (e.g., messages relating to property damage).

1.2 Save These Instructions

This manual contains important instructions for the generator set that should be followed during installation, operation and maintenance of the generator set and batteries.

Thoroughly read the operator manual before operating the generator set. Safe operation and top performance can only be obtained when equipment is properly operated and maintained.

The following symbols in this manual alert you to potential hazards to the operator, service person and equipment.

⚠ DANGER

Alerts you to an immediate hazard that will result in severe personal injury or death.

⚠ WARNING

Alerts you to a hazard or unsafe practice that can result in severe personal injury or death.

⚠ CAUTION

Alerts you to a hazard or unsafe practice that can result in personal injury or equipment damage.

1.3 General Information

This manual should form part of the documentation package supplied by Cummins Inc. with specific generator sets. If this manual has been supplied in isolation, please contact your authorized dealer.

NOTICE

It is in the operator's interest to read and understand all warnings and cautions contained in the documentation relevant to the generator set operation and daily maintenance.

1.4 General Precautions

- Keep multi-type ABC fire extinguishers accessible.
- Make sure that all fasteners are secure and torqued properly.
- Keep the generator set and its compartment clean. Do not store any items in the generator set compartment.
- Before working on the generator set, make sure the generator set is shut down and disabled.
 1. Press the generator set's "O" (Off) button or the red STOP button on the local display (whichever is applicable) to stop the generator set. Allow the generator set to thoroughly cool to the touch.
 2. If applicable, turn off and disconnect the battery charger from the AC source before disconnecting the battery cables.
 3. Disconnect the negative (–) cable from the battery and secure it from contacting the battery terminals to prevent accidental starting.

- Use caution when making adjustments when the generator set is running, hot, or when parts are electrically live, as all situations may cause personal injury or death.
- Used engine oil has been identified by some state and federal agencies as causing cancer or reproductive toxicity. Do not ingest, inhale, or come into contact with used oil or its vapors.
- Do not work on the generator set when mentally or physically fatigued or after consuming alcohol or drugs.

NOTICE

Only trained and authorized personnel shall maintain or service the generator set.

NOTICE

The installation of the generator set shall provide enough ventilation to ensure that gases generated by vented batteries during charging, or caused by equipment malfunction, are removed.

General Safety Precautions

⚠ WARNING

Hot Pressurized Liquid

Contact with hot liquid can cause severe burns.

Do not open the pressure cap while the engine is running. Let the engine cool down before removing the cap. Turn the cap slowly and do not open it fully until the pressure has been relieved.

⚠ WARNING

Moving Parts

Moving parts can cause severe personal injury.

Use extreme caution around moving parts. All guards must be properly fastened to prevent unintended contact.

⚠ WARNING

Toxic Hazard

Used engine oils have been identified by some state and federal agencies to cause cancer or reproductive toxicity.

Do not ingest, breathe the fumes, or contact used oil when checking or changing engine oil. Wear protective gloves and face guard.

⚠ WARNING***Electrical Generating Equipment***

Incorrect operation and maintenance can result in severe personal injury or death.

Do not operate equipment when fatigued, or after consuming any alcohol or drug.

Make sure that only suitably trained and experienced service personnel perform electrical and/or mechanical service.

⚠ WARNING***Toxic Gases***

Substances in exhaust gases have been identified by some state and federal agencies to cause cancer or reproductive toxicity.

Do not breathe in or come into contact with exhaust gases.

⚠ WARNING***High Noise Level***

Generator sets in operation emit noise, which can cause hearing damage.

Wear appropriate ear protection at all times.

⚠ WARNING***Hot Surfaces***

Contact with hot surfaces can cause severe burns.

The unit is to be installed so that the risk of hot surface contact by people is minimized. Wear appropriate PPE when working on hot equipment and avoid contact with hot surfaces.

⚠ WARNING***Toxic Hazard***

Ethylene glycol, used as an engine coolant, is toxic to humans and animals.

Wear appropriate PPE. Clean up coolant spills and dispose of used coolant in accordance with local environmental regulations.

⚠ WARNING***Combustible Liquid***

Ignition of combustible liquids is a fire or explosion hazard which can cause severe burns or death.

Do not store fuel, cleaners, oil, etc., near the generator set. Do not use combustible liquids like ether.

⚠ WARNING**Combustible Gases**

Generator sets in operation have combustible gases under pressure, which if ignited can cause eye and ear damage.

Wear appropriate eye and ear protection at all times.

⚠ WARNING**Combustible Gases**

Generator sets in operation have combustible gases under pressure, which if ignited can cause severe injury.

Do not operate the generator set with any doors open.

⚠ WARNING**Fire Hazard**

Materials drawn into the generator set, as well as accumulated grease and oil, are a fire hazard. Fire can cause severe burns or death.

Keep the generator set and the surrounding area clean and free from obstructions. Make sure the generator set is mounted in a manner to prevent combustible materials from accumulating under the unit.

⚠ WARNING**Automated Machinery**

Accidental or remote starting of the generator set can cause severe personal injury or death.

Isolate all auxiliary supplies and use an insulated wrench to disconnect the starting battery cables (negative [-] first).

NOTICE

Keep multi-type ABC fire extinguishers close by. Class A fires involve ordinary combustible materials such as wood and cloth. Class B fires involve combustible and flammable liquid fuels and gaseous fuels. Class C fires involve live electrical equipment. (Refer to NFPA No. 10 in the applicable region.)

NOTICE

Before performing maintenance and service procedures on enclosed generator sets, make sure the service access doors are secured open.

NOTICE

Stepping on the generator set can cause parts to bend or break, leading to electrical shorts, or to fuel, coolant, or exhaust leaks. Do not step on the generator set when entering or leaving the generator set room.

1.5 Generator Set Voltage Is Deadly

- Generator set output connections must be made by a trained and experienced electrician in accordance with all applicable codes.
- This generator set and the public utility may only be connected to house circuits by means of the automatic transfer switch.

⚠ CAUTION

Improper connections can lead to electrocution of utility workers and damage to equipment. Make sure that the connections are installed properly by a trained technician.

- Use caution when working on live electrical equipment. Remove jewelry, and make sure clothing and shoes are dry. Stand on a dry wooden platform.

1.6 Fuel and Fumes Are Flammable

Fire, explosion, and personal injury or death can result from improper practices.

- DO NOT permit any flame, cigarette, pilot light, spark, arcing equipment, or other ignition source near the generator set or fuel system.
- Fuel lines must be adequately secured and free of leaks. Fuel connection at the engine should be made with an approved flexible line. Do not use copper piping on flexible lines because copper will become brittle if continuously vibrated or repeatedly bent.
- Be sure all fuel supplies have a positive shutoff valve.
- Be sure the battery area has been well-ventilated prior to servicing near it. Lead-acid batteries emit a highly explosive hydrogen gas that can be ignited by arcing, sparking, smoking, etc.

1.7 Starting Batteries

WARNING

Toxic Hazard

The electrolyte in starting batteries is a dilute sulfuric acid that is harmful to the skin and eyes. It is also electrically conductive and corrosive.

Always:

- 1. Wear full eye protection and protective clothing;**
- 2. If the electrolyte contacts the skin, wash it off immediately with water;**
- 3. If the electrolyte contacts the eyes, flush them thoroughly and immediately with water and seek medical attention; and**
- 4. Wash spilled electrolyte down with an acid neutralizing agent. A common practice is to use a solution of one pound (500 grams) bicarbonate of soda (also known as baking soda or sodium bicarbonate) to one gallon (4 liters) of water.**
- 5. Continue to add the bicarbonate of soda solution until the evidence of reaction (that is, foaming) has stopped.**
- 6. Flush the resulting liquid with water and dry the area.**

1.8 Batteries Can Explode

Batteries can explode, causing severe skin and eye burns and can release toxic electrolytes.

WARNING

Combustible Gases

Batteries can explode, causing severe skin and eye burns, and can release toxic electrolytes.

Do not dispose of the battery in a fire, because it is capable of exploding. Do not open or mutilate the battery. Do not charge frozen batteries.

WARNING

Electric Shock Hazard

Batteries present the risk of high short circuit current.

When servicing the generator set:

- Remove watches, rings, or other metal objects.**
- Use tools with insulated handles.**

NOTICE

Servicing of batteries must be performed or supervised by personnel knowledgeable of batteries and the required precautions. Keep unauthorized personnel away from batteries.

- Wear safety glasses.
- Do not smoke.
- Do not charge frozen batteries.
- To prevent arcing when disconnecting the battery:
 1. Press the Off switch from the display and then press the E-Stop button.
 2. Disconnect AC power from any battery chargers.
 3. Remove the negative (-) battery cable to prevent starting.
- To prevent arcing when reconnecting the battery:
 1. Reconnect the positive (+) cable.
 2. Reconnect the negative (-) cable.
 3. Reconnect the battery charger to AC power supply.
- When replacing the generator set battery, always replace it with a battery as specified in this manual.

1.9 Vented Batteries

⚠ WARNING***Toxic Hazard***

The electrolyte in vented batteries is a dilute sulfuric acid that is harmful to the skin and eyes. It is also electrically conductive and corrosive.

Always:

- 1. Wear full eye protection and protective clothing;***
- 2. If the electrolyte contacts the skin, wash it off immediately with water;***
- 3. If the electrolyte contacts the eyes, flush them thoroughly and immediately with water and seek medical attention; and***
- 4. Wash spilled electrolyte down with an acid neutralizing agent. A common practice is to use a solution of one pound (500 grams) bicarbonate of soda (also known as baking soda or sodium bicarbonate) to one gallon (4 liters) of water.***
- 5. Continue to add the bicarbonate of soda solution until the evidence of reaction (that is, foaming) has stopped.***
- 6. Flush the resulting liquid with water and dry the area.***

1.10 Moving Parts Can Cause Severe Personal Injury or Death

- Do not wear loose clothing or jewelry near moving parts, such as cooling fans.
- Keep hands away from moving parts.
- Keep guards in place over fans.

1.11 Exhaust Gases Are Deadly

- Provide an adequate exhaust system to properly expel discharged gases away from enclosed or sheltered areas, and areas where individuals are likely to congregate. Visually and audibly inspect the exhaust system daily for leaks per the maintenance schedule. Make sure that exhaust manifolds are secured and not warped. Do not use exhaust gases to heat a compartment.
- Make sure the unit is well ventilated.

Exhaust Precautions

WARNING

Hot Exhaust Gases

Contact with hot exhaust gases can cause severe burns.

Wear personal protective equipment when working on equipment.

WARNING

Hot Surfaces

Contact with hot surfaces can cause severe burns.

The unit is to be installed so that the risk of hot surface contact by people is minimized. Wear appropriate PPE when working on hot equipment and avoid contact with hot surfaces.

WARNING

Toxic Gases

Inhalation of exhaust gases can cause asphyxiation and death.

Pipe exhaust gas outside and away from windows, doors, or other inlets to buildings. Do not allow exhaust gas to accumulate in habitable areas.

WARNING

Fire Hazard

Contaminated insulation is a fire hazard. Fire can cause severe burns or death.

Remove any contaminated insulation and dispose of it in accordance with local regulations.

The exhaust outlet may be sited at the top or bottom of the generator set. Make sure that the exhaust outlet is not obstructed. Personnel using this equipment must be made aware of the exhaust position. Position the exhaust away from flammable materials - in the case of exhaust outlets at the bottom, make sure that vegetation is removed from the vicinity of the exhaust.

The exhaust pipes may have some insulating covers fitted. If these covers become contaminated they must be replaced before the generator set is run.

To minimize the risk of fire, make sure the following steps are observed:

- Make sure that the engine is allowed to cool thoroughly before performing maintenance or operation tasks.
- Clean the exhaust pipe thoroughly.

1.12 The Hazards of Carbon Monoxide

Carbon monoxide (CO) is an odorless, colorless, tasteless and non-irritating gas. You cannot see it or smell it. Red blood cells, however, have a greater affinity for CO than for oxygen. Therefore, exposure even to low levels of CO for a prolonged period can lead to asphyxiation (lack of oxygen) resulting in death. Mild effects of CO poisoning include eye irritation, dizziness, headaches, fatigue and the inability to think clearly. More extreme symptoms include vomiting, seizures and collapse.

Engine-driven generator sets produce harmful levels of carbon monoxide that can injure or kill you.

Special Risks of CO near the Home

WARNING

Toxic Gases

Carbon monoxide (CO) gas can cause nausea, fainting, or death. Residents can be exposed to lethal levels of CO when the generator set is running. Depending on air temperature and wind, CO can accumulate in or near the home.

To protect yourself and others from the dangers of CO poisoning, it is recommended that reliable, approved, and operable CO detector alarms are installed in proper locations in the home as specified by their manufacturer.

Protecting Yourself from CO Poisoning

- Locate the generator set in an area where there are no windows, doors, or other access points into the home.
- Make sure all CO detectors are installed and working properly.
- Pay attention for signs of CO poisoning.
- Check the exhaust system for corrosion, obstruction, and leaks every time you start the generator set and every eight hours when you run it continuously.

2 Introduction

2.1 About This Manual

⚠ WARNING

Improper installation can result in severe personal injury, death and damage to equipment. The installation must comply with all applicable building codes (including project permits and inspections). The installer should be properly trained and licensed to perform electrical and mechanical equipment installations (including gaseous fuel installation).

NOTICE

Manuals are updated from time to time to reflect changes in the equipment and its specifications. The most up-to-date version of this manual is found on the QuickServe website (<https://quickserve.cummins.com/info/index.html>).

This manual is a guide for the installation of the generator set models listed on the front cover. Proper installation is essential for top performance, reliable operation, and safety. Read through this manual before starting the installation. This manual covers outdoor applications only; for other installations, refer to the *T-030: Liquid-Cooled Generator Set Application* manual available from your Cummins distributor.

NOTICE

The installation must comply with all applicable building codes.

See the generator set's specific operator manual for operation and maintenance and specific service manual for service.

Refer to the Model Specifications section for specific information about the system and its components.

Refer to the Outline and System Drawings appendix and the Wiring Diagrams appendix for specific information about installation and wiring connections.

2.2 Schedule of Abbreviations

This list is not exhaustive. For example, it does not identify units of measure or acronyms that appear only in parameters, event/fault names, or part/accessory names.

Abbr.	Description	Abbr.	Description
AC	Alternating Current	LED	Light-Emitting Diode
AMP	AMP, Inc. (part of Tyco Electronics)	MFM	Multifunction Monitor
ANSI	American National Standards Institute	Mil Std	Military Standard
ASOV	Automatic Shut Off Valve	MPU	Magnetic Pickup
ASTM	American Society for Testing and Materials (ASTM International)	NC	Normally Closed
ATS	Automatic Transfer Switch	NC	Not Connected
AVR	Automatic Voltage Regulator	NFPA	National Fire Protection Agency
AWG	American Wire Gauge	NO	Normally Open
CAN	Controlled Area Network	NWF	Network Failure
CB	Circuit Breaker	OEM	Original Equipment Manufacturer
CE	Conformité Européenne	OOR	Out Of Range
CCA	Cold Cranking Ampere	OORH/ ORH	Out Of Range High
CFM	Cubic Feet per Minute	OORL/ORL	Out Of Range Low
CGT	Cummins Generator Technologies	PB	Push Button
CMM	Cubic Meters per Minute	PCC	PowerCommand® Control
CT	Current Transformer	PGI	Power Generation Interface
DC	Direct Current	PGN	Parameter Group Number
DEF	Diesel Exhaust Fluid	PI	Proportional/Integral
DPF	Diesel Particulate Filter	PID	Proportional/Integral/ Derivative
EBS	Excitation Boost System	PLC	Programmable Logic Controller
ECM	Engine Control Module	PMG	Permanent Magnet Generator

Abbr.	Description	Abbr.	Description
ECS	Engine Control System	PPE	Personal Protective Equipment
EMI	Electromagnetic Interference	PT	Potential Transformer
EN	European Standard	PTC	Power Transfer Control
EPS	Engine Protection System	PWM	Pulse-Width Modulation
E-Stop	Emergency Stop	RFI	Radio Frequency Interference
FAE	Full Authority Electronic	RH	Relative Humidity
FMI	Failure Mode Identifier	RMS	Remote Monitoring System
FSO	Fuel Shutoff	RMS	Root Mean Square
Genset	Generator Set	RTU	Remote Terminal Unit
GCP	Generator Control Panel	SAE	Society of Automotive Engineers
GND	Ground	scfh	Standard Cubic Feet of gas per Hour
HMI	Human-Machine Interface	SCR	Selective Catalytic Reduction
IC	Integrated Circuit	SPN	Suspect Parameter Number
ISO	International Organization for Standardization	SW_B+	Switched B+
LBNG	Lean-Burn Natural Gas	UL	Underwriters Laboratories
LCD	Liquid Crystal Display	UPS	Uninterruptible Power Supply
LCT	Low Coolant Temperature		

2.3 Related Literature

Before any attempt is made to operate the generator set, the operator should take time to read all of the manuals supplied with the generator set and familiarize themselves with the warnings and operating procedures.

A generator set must be operated and maintained properly if you are to expect safe and reliable operation. The Operator manual includes a maintenance schedule and a troubleshooting guide. The Health and Safety manual must be read in conjunction with the Operator manual for the safe operation of the generator set.

The following documents are shipped with the generator set:

- Installation Manual for QSJ8.9G Engine with PowerCommand 2.3 Control (A056K396)
- Operator Manual for QSJ8.9G Engine with PowerCommand 2.3 Control (A056K398)
- Health and Safety Manual (0908-0110-00)
- Global Commercial Warranty Statement (A040H442)
- Emission Warranty Statement (Federal Emissions EPA Title 40 CFR Part 90 Component Warranty) (A028X279)

The relevant manuals appropriate to your generator set are also available; the documents below are in English:

- Generator Set Service Manual for QSJ8.9G Engine with PowerCommand 2.3 Control (A056K400)
- Controller Service Manual for PowerCommand 2.3 Controller (A030F082 [0900-0666])
- Recommended Spares List (RSL) for each model:
 - C125 N6 (A057P648)
 - C150 N6 (A057P650)
- Parts Manual for QSJ8.9G Engine with PowerCommand 2.3 Control (A056K402)
- Universal Annunciator Owner Manual (0900-0301)
- Standard Repair Times - IB Family (A057P652)
- Service Tool Manual (A043D529)
- Failure Code Manual (F1115C)
- Engineering Application Manual T-030: Liquid Cooled Generator Sets (A040S369)

2.4 Model Specifications

NOTICE

Damage caused by failure to follow the manufacturer's recommendation will not be covered by the warranty. Please contact your authorized distributor.

TABLE 1. 8.9L MODEL VARIATIONS

Models	Description
C125 N6, C150 N6	60 Hz, 1800 RPM

TABLE 2. COLD WEATHER SPECIFICATIONS (ALL MODELS)

Temperature	Description of Components	Battery Quantity	Group
Above 4 °C (40 °F)	Battery charger	1	34
-17 - 4 °C (0 to 40 °F)	Battery charger, coolant heater (1500 W), CCV heater*	1	34
Below -17 °C (0 °F)	Battery charger, coolant heater (2000 W), oil heater, battery heater, CCV heater*	2	34

*CCV heaters are provided as part of the cold and extreme cold coolant heater packages.

NOTICE

For NFPA 110 applications, a coolant heater is required. A factory option is available.

TABLE 3. FUEL SPECIFICATIONS 60 HZ, 1800 RPM

Type	Unit	C125 N6	C150 N6
Natural Gas Full Load	scfh	1655	1893.3
	BTU/hr	1,580,079	1,807,610
Fuel Pressure	1.5 - 3.2 kPa (6 to 13 inches of water column) under any condition		

TABLE 4. ENGINE SPECIFICATIONS (ALL MODELS)

Type	Specification
Engine	6 cylinder in-line, single-cam, liquid-cooled, 4-stroke, spark ignited
Bore	114 mm (4.49 in)
Stroke	145 mm (5.69 in)
Displacement	8.9 L (543.1 in ³)
Compression Ratio (Natural Gas)	9.7:1
Firing Order	1-5-3-6-2-4

Type	Specification
Spark Plug Gap	0.40 mm (.016 in)
Spark Plug Torque	38 Nm (28 ft-lb)
Crankshaft Rotation (Viewed from the Front of the Engine)	Clockwise
Engine Weight (Dry, Long Block Only)	693 kg (1527.8 lb)
Valve Clearance (Intake)	0.355 mm (0.014 in)
Valve Clearance (Exhaust)	0.6604 mm (0.026 in)
Coolant	<ul style="list-style-type: none"> • 50/50 coolant solution (50% pure water and 50% anti-freeze) • 11 L (2.9 gal) capacity
Oil Capacity	22 L (5.81 gal)
Oil Standards	<ul style="list-style-type: none"> • Must adhere to Cummins® Engineering Standard (CES) 20085 • Use of improper oils can result in engine damage. Use only the required oils: <ul style="list-style-type: none"> ◦ 5W-40 (all ambient temperatures) ◦ 15W-40 (above 4 °C [40 °F] ambient temperature) (use of GEO 15W-40 oil in ambient temperatures below 4 °C (40 °F) could result in engine turbocharger damage) • A sulfated ash limit of 0.6% mass has been placed on all engine lubricating oils recommended for use in Cummins® B, natural gas engines. Higher ash oils can cause valve and/or piston damage, cause spark plug fouling, and lead to excessive oil consumption and degradation of the catalyst.

TABLE 5. LUBRICATING OIL SYSTEM SPECIFICATIONS

Type	Specification
Lubricating Oil Pressure at Idle (Minimum)	69 kPa (10 psi)
Lubricating Oil Pressure at Rated Speed (Minimum)	138 kPa (20 psi)
Filter Bypass Valve-Opening Pressure	345 kPa (50 psi)
Pressure Regulator Valve-Opening Pressure	417 kPa (60 psi)
Lubricating Oil Capacity (Standard Sump):	
--High	19 L (20 qt)

Type	Specification
--Low	15 L (16 qt)
--Total System	20.8 L (22 qt)

TABLE 6. GENERATOR SET SIZE SPECIFICATIONS

Enclosure Type	Size (L x W x H)
Open/Weather	2867 x 1016 x 1666 mm (113 x 40 x 65.6 in); does not include exhaust discharge elbow
Sound Level 1	3621 x 1016 x 1666 mm (143 x 40 x 65.6 in)
Sound Level 2	4061 x 1016 x 1666 mm (160 x 40 x 65.6 in)

TABLE 7. GENERATOR SET WET WEIGHT (ALL MODELS) (60 HZ, 1800 RPM)

Configuration	lbs	kg
Open	3475	1576
Weather	3801	1724
Sound Level 1	3907	1772
Sound Level 2	3940	1787

NOTICE

Weights are approximate and can be affected by selected options. Refer to outline drawings for specific weight information.

TABLE 8. ALTERNATOR SPECIFICATIONS 60 HZ, 1800 RPM

Type	C125 N6	C150 N6
Generator	Brushless, 4-pole rotating field, single bearing	
Power (kVA) 1 Phase	125	150
Power (kVA) 3 Phase	156.25	187.5

Type	C125 N6	C150 N6
Rated Voltages (V)	120/240, 1 Ph (Reconnectable)	
	227/480, 3 Ph WYE	
	347/600, 3 Ph WYE	
	120/240, 3 Ph DELTA	
	120/208, 3 Ph WYE	
	127/220, 3 Ph WYE	

NOTICE

Maximum $I_2 = 8\%$. Generator set load unbalance must not exceed 25% between any phases.

TABLE 9. GENERATOR SET DERATING GUIDELINES

Model	Phase	Engine Power Available Up To...		Derate At...	
		Elevation	Ambient Temperature	Elevation	Temperature
C125 N6	1 & 3	2010 m (6600 ft)	40 °C (104 °F)	4.5% per 300 m (985 ft)	1.5% per 10 °C (18 °F)
C150 N6	1 & 3	885 m (2900 ft)			

TABLE 10. CONTROL SPECIFICATIONS (ALL MODELS)

Control	Purpose
PowerCommand 2.3	Generator Set
Enovation 4G LDI	Engine (125, 150 kW Generator Sets)

TABLE 11. DC SYSTEM SPECIFICATIONS (ALL MODELS)

Type	Specification
Nominal Battery Voltage	12 VDC
Battery Group	34 (1 standard; 2 optional)
Battery Type	Lead acid, maintenance-free
Minimum Cold Crank Amps	850 standard, 1080 high capacity

TABLE 12. FUSE SPECIFICATIONS

Fuse	Amps	Volts	Comment
F1	20	32	¼" x 1¼" cylindrical glass cartridge, fast acting
F2	10		
F3	20		
F4	5		
F5	20		
F6	10		
F7	10	600	Class G size-rejecting, current limiting
F8	10		

2.5 Before Installation

Before beginning the installation of the generator set, verify that the unit was correctly selected. Check the following features:

- Model
- Specifications
- Options
- Fuel Supply
 - The gas supplied to the generator set must be of acceptable quality.
 - The gas supply must have sufficient pressure. Care must be taken to be sure that the gas supply at the generator set, not just at the source, is of proper pressure for operation. The specified pressure must be available while the generator set is starting and running at full load.
 - The gas must be supplied to the generator set in sufficient volume to support operation of the generator set. This is normally a matter of selecting fuel line size to be large enough to transport the volume of fuel needed.

This page is intentionally blank.

3 Pre-Installation Considerations

Areas of consideration:

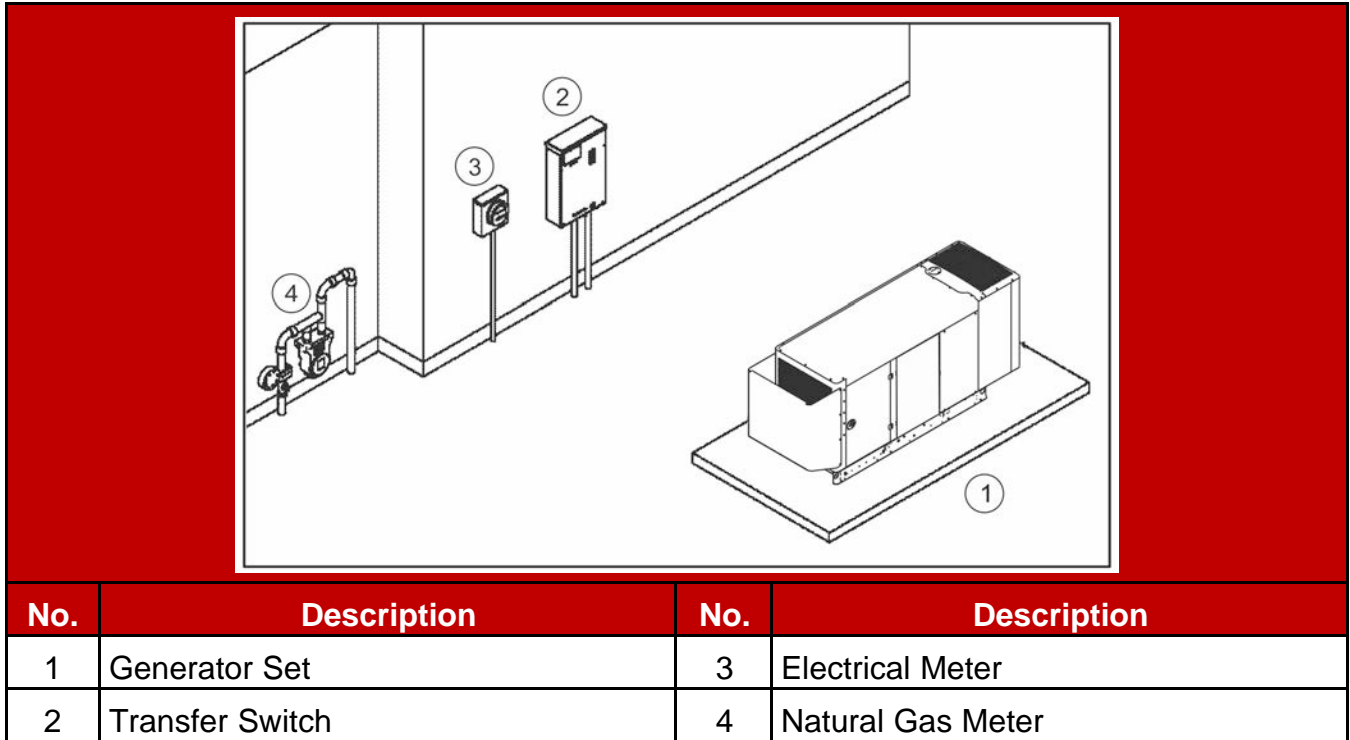

FIGURE 1. SITE PREPARATION EXAMPLE

- Location of the generator set - this is one of the first decisions to be made, as it affects all other aspects of the installation, such as:
 - Length of electric wiring
 - Length of gas lines (natural gas line must be inspected by the gas utility inspectors and building inspectors)
 - Site preparation:
 - Access to the site
 - Trenches
 - Site preparation materials needed
- Fuel supply pressure
- Automatic transfer switch location and connections
- Tools and materials required
- Accessories required (if any) for the customer's application (utility power may be required at the generator set; make plans accordingly)

NOTICE

Depending on the locality and use of the generator set, it may be necessary to obtain an air quality emissions permit before installation begins. Check with local pollution control or air quality authority to determine permit requirements.

3.2 Installation Codes and Standards for Safety

NOTICE

The generator set installer bears sole responsibility for following all applicable local codes and regulations.

The following list of codes and standards may apply to the installation and operation of the generator set. This list is for reference only and not intended to be inclusive of all applicable codes and standards. The address of each agency is listed so that copies of the codes may be obtained for reference. Installation codes and recommendations are subject to change, and may vary by location or over time.

TABLE 13. INSTALLATION CODES AND STANDARDS FOR SAFETY RECOMMENDATIONS

Type	Code or Standard	Title	Organization
US	Code	NFPA 70 - National Electrical Code	National Fire Protection Association 470 Atlantic Avenue Boston, MA 02210
	Code	NFPA 37 - Installation and Use of Stationary Combustion Engines and Gas Turbines	
	Code	NFPA 54 - National Fuel Gas Code	
	Code	NFPA 58 - Storage and Handling of Liquefied Petroleum Gases	
	Code	NFPA 110 - Standard for Emergency and Standby Power Systems	
Canada	Code	CSA Electrical Bulletin	Canadian Standards Association Housing and Construction Materials Section 178 Rexdale Blvd. Rexdale, Ontario, Canada M9Q 1R3
	Code	CSA 22.1 Canadian Electrical Code	
	Code	CSA B149 Installation Code for Gas Burning Appliances and Equipment	
	Standard	CSA C22.2 No. 100 Motors and Generators	
	Standard	CSA C22.2 No. 14 Industrial Control Equipment	
	Code	CSA C282 Emergency Electrical Power Supply for Buildings	
California	Code	California Administrative Code - Title 25 Chapter 3	State of California Documents Section P.O. Box 1015 North Highlands, CA 95660

3.3 Required Items for Installation

Tools and materials are used for the installation of this generator set. These items are identified in the following sections. Please refer to local codes and standards, because they may affect the materials required.

Materials Required

NOTICE

Refer to local codes and standards, which may affect material requirements.

NOTICE

If a 100% rated breaker is used, 90 °C (194 °F) wire must be used with the wire size determined by the 75 °C (167 °F) ampacity tables. Aluminum wire is not allowed with 100% rated breakers.

NOTICE

If required, a UL-listed grounding electrode terminal within its ratings and suitable for the application must be installed and labeled "Grounding Electrode Terminal".

Electrical Materials:

NOTICE

Class 1 wiring methods must be used for connecting the generator set.

- Use code compliant AC wiring for phase, neutral, and ground connections.
- Wire sizes (DC control and power and AC sense only):
 - Control wires under 305 m (1000 feet) circuit length => 18-14 AWG of the insulation type below
 - Control wires 305 - 610 m (1000 - 2000 feet) circuit length => 16-14 AWG of the insulation type below
- All control wires and cables must be rated 75 °C (167 °F) minimum, stranded copper, and rated for wet locations.
 - For wire sizes 14 AWG and larger, use insulation types: RHW, RHW-2, THHW, THW, THW-2, THWN, THWN-2, XHHW, XHHW-2, USE-2, ZW-2
 - For wire sizes 16 and 18 AWG, use insulation types: FFH-2, KFF-2, PAFF, PFF, PGFF, PTF, RFH-2, RFHH-2, RFHH-3, SFF-2, TFF, TFFN, ZFF
- Code compliant 20 A, 120 VAC, GFCI protected circuit for alternator heaters, battery charger, coolant heater, oil heater, and/or battery heater (if equipped)

NOTICE

The optional high wattage coolant heater operates at 240 VAC.

- Code-compliant conduit for all wires
- Circuit breaker wire binding screws: 3/16", 5/16", 1/2", 6 mm, 8 mm hex bit
- Customer connections to auxiliary I/O boards and relays
- Pozidriv screwdriver #2 and #3

NOTICE

Seismic zone installations require compliance to specific mounting configurations.

Fuel Materials:

- Flexible fuel line (provided with the generator set, attached to the radiator guard)
- UL listed pipe thread sealant
- Fuel line at generator set (natural gas fuel pressure: 1.5 - 3.2 kPa/6 - 13 inches water column)
- Fuel pressure regulator (as required)
- Manual fuel shut-off at generator set ahead of automatic valves on generator set fuel system

Tools Required

Use appropriate lifting techniques to position the generator set in place.

Loose Parts Shipped with the Generator Set

The following loose parts are shipped with the generator set:

- Flexible fuel hose assembly (attached to the radiator guard)
- One enclosure key (where applicable)
- Battery tie-down
- Sound level 2 baffle (where applicable)
- Weather enclosure exhaust elbow (where applicable)
- Literature (operator manual, installation manual, health and safety manual, and warranty statements)

This page is intentionally blank.

4 Installation

4.1 Site Assessment and Preparation

Proper component location and site preparation have a very important impact on completing a successful installation. The major components and sources of power needed for installation include the following items:

- Generator set
- Transfer switch
- Electrical utility
- Fuel source
- Accessories (may be required under certain conditions)

Generator Set Installation Suggestions and Guidelines

- Locate the generator set on stable ground, not subject to flooding. Generator set should not be installed where significant water runoff from a roof or downspouts is present. Sump pump discharge should be routed away from the generator set.
- Locate and orient the generator set such that prevailing winds will carry exhaust gases and fuel leaks away from the house or occupied areas.
- This unit is to be installed so that the risk of contact by people is minimized.

Picking a Location

 **WARNING**

Exhaust gas is deadly. Locate the generator set away from doors, windows, and other openings to the house and where exhaust gases will disperse away from the house.

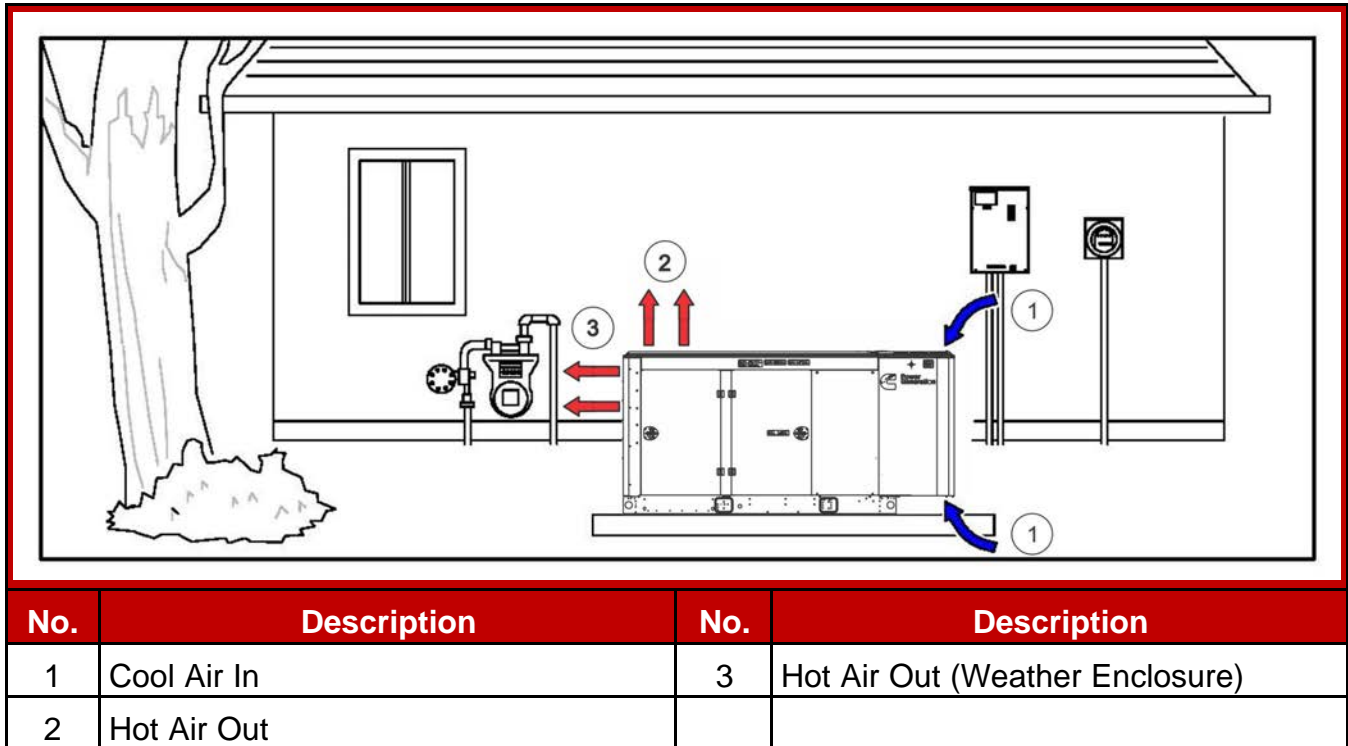

FIGURE 2. EXAMPLE OF GENERATOR SET LOCATION

The generator set location is critical for safety and performance. Follow the guidelines below:

- Must comply with applicable codes (NFPA, NEC, IBC, etc.).
- Install outdoors only. For other applications, contact your local Cummins dealer or refer to the application manual at the following link: <http://www.cumminspower.com/www/literature/applicationmanuals/t030.pdf>
- Consider access to utilities (electric/gas meters, transfer switch, remote fuel tank location [for liquid propane if applicable], etc.).
- Call the local utilities to mark the locations of buried utility services (gas, electric, or telephone) before digging.
- Verify the locations of any other buried components (gas, electric or telephone) with the homeowner before digging.

Follow the clearance guidelines below:

- The generator set must be located 5 feet from combustible materials (NFPA 37) and any opening in a wall (window, door, vent, etc.).
- The generator set must be located such that the exhaust is not able to accumulate in an occupied area.
- The generator set must have enough room for installation, service, and maintenance.
- The generator set must be located to ensure ventilation openings are not blocked.

- Position the generator set so that cooling air is free to enter and leave the area.
- Locate and position the generator set so that prevailing winds carry exhaust gases and potential fuel leaks away from the house or occupied area.

NOTICE

For all clearance requirements, refer to the Outline and System Drawings section.

Laying the Foundation

When laying the foundation:

1. Clear obstructions, and make sure that there is adequate clearance for access.
2. Level the ground, and make sure that the ground is compact and settled. Ensure that it is stable ground, not subject to flooding.
3. Prepare the concrete pad.
 - The pad should be constructed of reinforced concrete with a 28-day compressive strength of at least 17,237 kPa (2500 psi).
 - The pad should be at least 127 mm (5 in) deep and extend at least 150 mm (6 in) beyond the skid on all sides.

NOTICE

Refer to the foundation drawing for stub-up dimensions.

NOTICE

Seismic installation may require a different pad and securing devices.

NOTICE

Local codes and standards may have different requirements.

4. Lift the generator set onto the pad, and secure it.

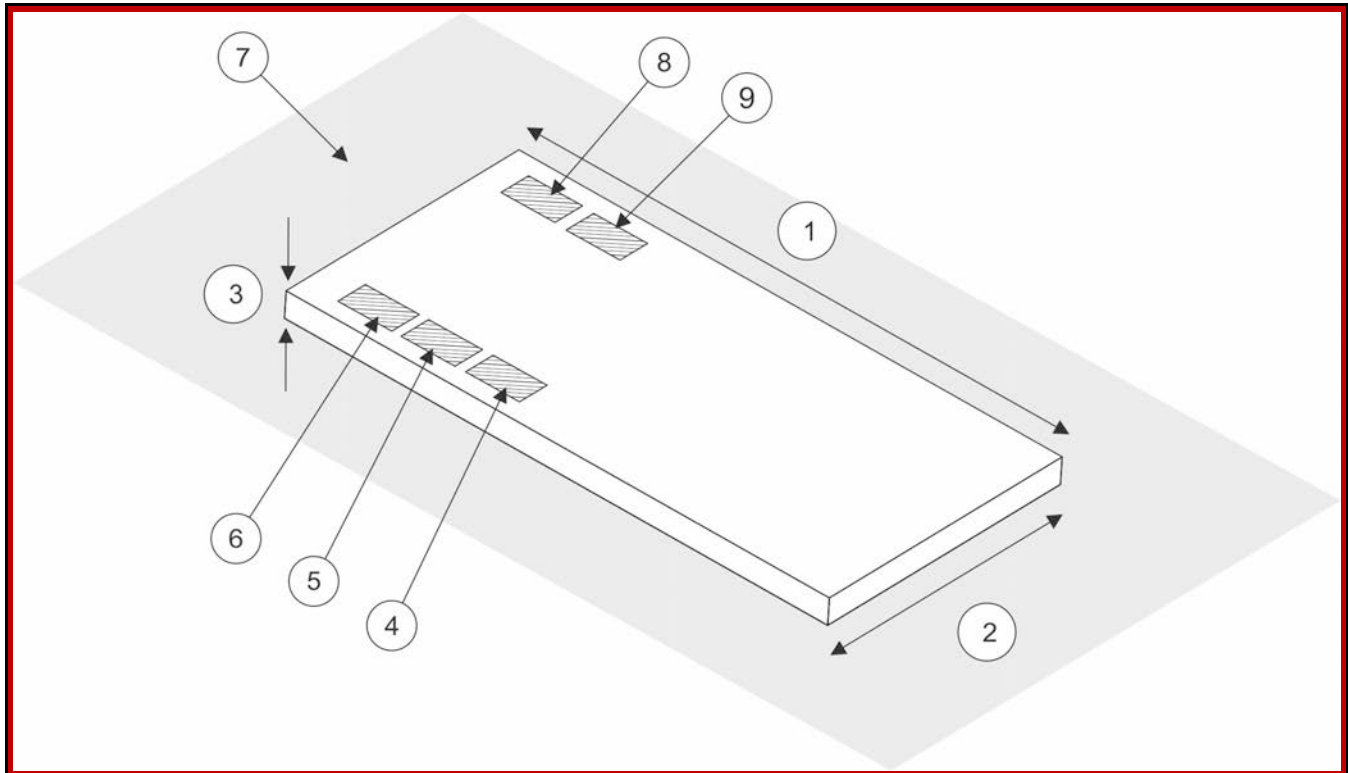

No.	Description	No.	Description
1	Pad Length (Must Extend Minimum 152 mm/6 in Beyond Skid)	6	Circuit Breaker 3 Stub-Up (Optional)
2	Pad Width (Must Extend Minimum 152 mm/6 in Beyond Skid)	7	1.5 m/5 ft Clearance (Shaded Area)
3	Pad Thickness (Minimum 127 mm/5 in)	8	Accessory 120 VAC, 20A Max Wire Stub-Up (240 VAC, 15A for High Wattage Coolant Heater)
4	Circuit Breaker 1 Stub-Up	9	Generator Set Control Wire Stub-Up (DC)
5	Circuit Breaker 2 Stub-Up (Optional)		

FIGURE 3. CONCRETE PAD PREPARATION

Lifting and Moving the Generator Set

⚠ WARNING
<p>Heavy Load <i>The generator set is heavy. Handle with care. Dropping the generator set can cause severe personal injury or death. Use appropriate lifting techniques to move the generator set. Keep feet and hands clear when lifting the generator set.</i></p>

⚠ CAUTION

The generator set is shipped with oil in the engine crankcase. Keep the generator set upright.

Mounting the Generator Set

Mount the generator set on a substantial and level base such as a concrete pad. A non-combustible material must be used for the pad. Verify that the mounting pad is level by length, by width, and diagonally.

NOTICE

Seismic installation may require specific anchorage.

4.2 Fuel System Connection

NOTICE

Fuel systems must be installed by qualified service technicians. Improper installation presents hazards of fire and improper operation, resulting in severe personal injury or property damage.

NOTICE

In some jurisdictions, fuel system installations to the generator set must be performed by licensed or registered personnel. Check with the authority having jurisdiction for requirements.

⚠ WARNING

Gaseous fuels are flammable, explosive, and can cause severe personal injury or death. Do not smoke if you smell gas, are near fuel tanks for fuel-burning equipment, or are in an area sharing ventilation with such equipment. Keep flames, sparks, pilot lights, electrical arcs, arc-producing equipment and all other sources of ignition well away. Keep a multi-type ABC fire extinguisher close by.

In all fuel system installations, cleanliness is extremely important.

- Make every effort to prevent fuel contamination from:
 - Moisture
 - Dirt
 - Excess thread sealant
 - Contaminants of any kind
- Clean all fuel system components before installing.

Gaseous-fuel supply system design, materials, components, fabrication, assembly, installation, testing, inspection, operation, and maintenance must comply with the applicable codes. See NFPA Standards No. 37, 54, and 58. If this is a seismic installation, refer to IBC codes and standards. Where seismic installation is required, there may be specific anchorage requirements for the generator set and other installed components.

Most codes require a manual shutoff valve ahead of a flexible fuel hose. The generator set includes electric (battery-powered) shutoff valves.

NOTICE

It is recommended that a shutoff valve be located near the generator set for emergency shut off or servicing the generator set. Follow applicable codes.

Until the generator set is connected, cap the fuel line stub-up at the generator set to prevent dirt from entering and gas from discharging if the gas supply shutoff valve is opened accidentally.

To determine the required capacity, refer to the Fuel System appendix.

Fuel Line Connections

WARNING

Fuel presents the hazard of fire or explosion that can result in severe personal injury or death. Do not smoke or allow any flame, spark, pilot light or other ignition sources near fuel or in the installation area. Read the important safety precautions in this manual.

1. Refer to the Outline and System Drawings appendix for the location of the fuel supply connection through the side of the generator set.
2. Install a flexible fuel hose, which must be used between the engine's fuel system and fuel supply line to protect the fuel system from damage caused by vibration, expansion and contraction. The fuel hose must be installed according to all applicable codes and standards.

Installing Fuel Lines

The basic components required for fuel line installation are as follows:

- Flexible fuel line (attached to the radiator guard)
- Fuel line
- Shutoff valve
- Fuel supply

To install the fuel lines:

1. Connect a flexible fuel line to the fuel connection ports on the generator set.
2. Connect the opposite end of the flexible fuel line to the fuel source line near the shutoff valve.

NOTICE

A shutoff valve is recommended and often required by local and state codes.

Natural Gas Fuel System

Requirements for a natural gas generator set are as follows:

TABLE 14. NATURAL GAS GENERATOR SET REQUIREMENTS

Component	Description
Gas	Pipeline quality
Fuel Supply	Adequate fuel supply to operate correctly and run at full load
Shutoff Valve	Manual
Fuel Pipe Size	The length of the fuel supply pipe from the gas service entrance to the generator set must be known to determine the correct fuel pipe size. Refer to the charts in the Fuel Line Selection appendix. Iron pipe must be a minimum of Schedule 40 subject to the authority having jurisdiction.
Flexible Fuel Line	Attached to the radiator guard. Protects the fuel system from vibration, expansion, and contraction.

 WARNING

Fuel leaks can lead to explosive accumulations of gas. Prevent gas leaks and the accumulation of gaseous fuel in the event of a leak.

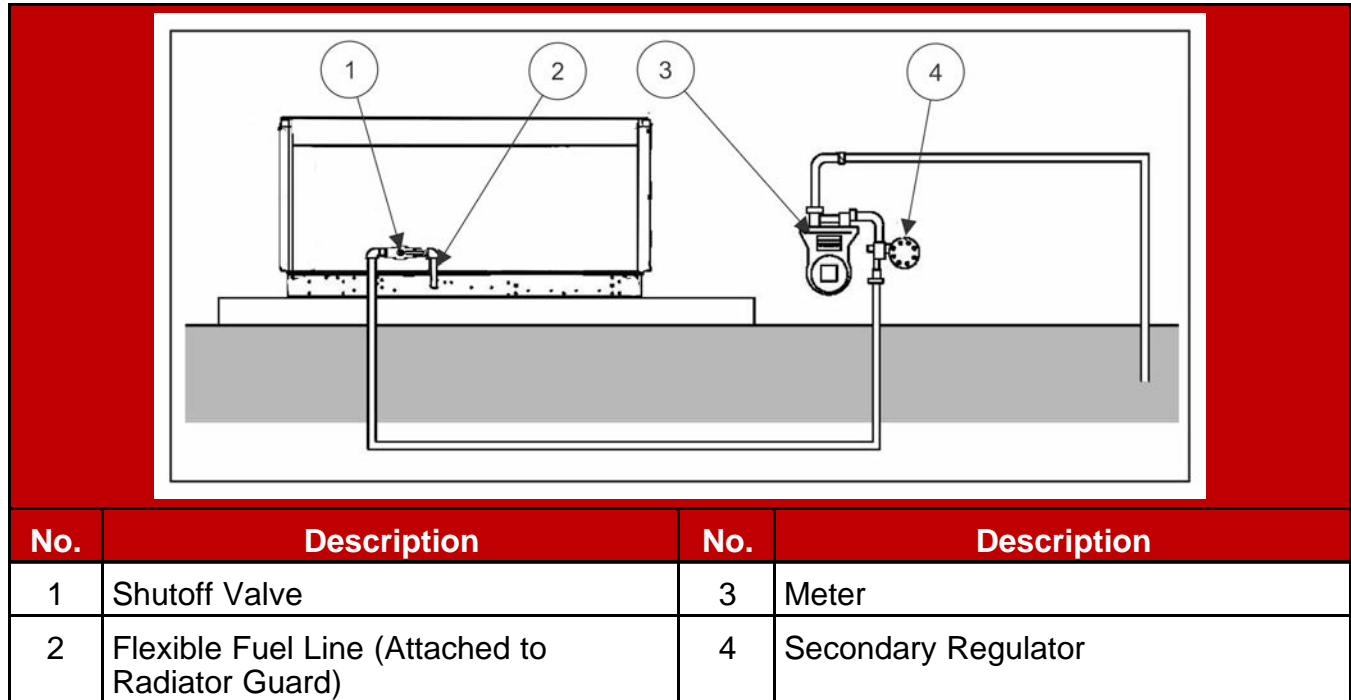

FIGURE 4. TYPICAL NATURAL GAS INSTALLATION

Natural Gas Supply Line Size

The natural gas supply meter may need to be exchanged for a higher capacity meter to supply the additional gas consumed by the generator set.

Use the total load requirement of the generator set to determine the size of the fuel supply pipe. Use the tables and charts in the Fuel Line Selection appendix to determine the correct pipe size.

An older site might require upgrading and repair of the gas supply system. Schedule an upgrade or repair to minimize power and gas supply interruptions.

Make sure the full load fuel supply pressure at the inlet to the generator fuel shutoff valves matches the requirements in the Model Specifications section.

Testing the Fuel System for Leaks

After assembly and before initial operation, all of the fuel system components must be tested and proven free of any leaks.

⚠ WARNING

Fuel presents the hazard of explosion or fire which can result in severe personal injury or death. Do not use an open flame to check for leaks. Do not smoke or allow any flame, spark, pilot light, arc-producing equipment, switch or other ignition sources around fuel or fuel components. Keep multi-type ABC fire extinguishers close by.

NOTICE

Follow any local codes and standards, as they may require a different method or documentation of a leak test.

Perform the following fuel piping system leak check:

1. After assembly and before initial operation of generator set, test all fuel system components as required per the National Fuel Gas Code (NFPA 54).
2. The National Fuel Gas Code requires that the generator set be isolated from the *piping* system by disconnecting it and capping the outlet prior to test. The test pressure required is the greater of 1.5 times the supply pressure or 3 psi (20.7 kPa) minimum.
3. After successfully completing the previous step, connect the generator set to the fuel piping system.
4. To verify that all connections from the fuel piping system to the generator set are free of leaks, conduct a bubble test using an approved leak detection solution (or equivalent method) with the system pressure of 0.8 to 1.0 psi (5.5 to 7.0 kPa).
5. Spray the bubble solution on all of the joints.
6. Inspect all of the joints and monitor the line pressure. If bubbles appear, there is a leak.
7. If any leaks are found, repair the joint or replace components as needed.
8. Verify the leak has been fixed.

NOTICE

The leak detection solution (that is, bubble solution) must be non-corrosive and be free of ammonia and chlorine.

4.3 Engine Exhaust

If the exhaust system for this generator set ships with a silencer, no further installation is needed. Do not modify any factory connections.

If the generator set is shipped with an NPT exhaust connection, the installer must add a silencer. Exhaust pressures must be verified for proper generator set operation.

⚠ WARNING

Exhaust gas is deadly. Make sure that the exhaust system terminates away from building vents, windows, doors, and sheltered spaces that may not have ample fresh air ventilation.

⚠ WARNING

Engine discharge air and exhaust carry carbon monoxide gas (odorless and invisible) which can cause asphyxiation and death. Never use engine discharge air or exhaust for heating a room or enclosed space.

4.4 Electrical Connections

⚠ WARNING

Improper installation can lead to electrocution and damage to property. Electrical connections must be made by a licensed electrician.

⚠ WARNING

Automatic startup of the generator set during installation can cause severe personal injury or death. Make sure the generator set is shut down and disabled:

- 1. Press the generator set's "O" (Off) button to stop the generator set. Allow the generator set to thoroughly cool to the touch.*
- 2. Turn off and disconnect the battery charger from the AC source before disconnecting the battery cables.*
- 3. Disconnect the negative (–) cable from the battery and secure it from contacting the battery terminals to prevent accidental starting.*

NOTICE

Refer to regional codes and the National Electrical Code (NFPA 70) for all electrical installation requirements.

NOTICE

Class 1 wiring methods must be used for connecting the generator set.

Electrical Preparations

Connect the conduits to the generator set. Refer to the specific outline drawing in the Outline and System Drawings appendix.

NOTICE

Be sure to account for any needed accessories, such as a remote display, etc.

AC Connections

WARNING

Automated Machinery

Accidental or remote starting of the generator set can cause severe personal injury or death.

Isolate all auxiliary supplies and use an insulated wrench to disconnect the starting battery cables, negative (–) cable first.

NOTICE

If a 100% rated breaker is used, 90 °C (194 °F) wire must be used with the wire size determined by the 75 °C (167 °F) ampacity tables.

NOTICE

When using a circuit breaker with an adjustable, electronic trip unit, the amperage and trip curve settings may need adjustment to match the generator set load wiring, or downstream loads and circuit breakers. An accessory seal kit (part number A026M166) is available to tamper-proof the adjustable settings.

1. Make sure the generator set is shut down and disabled:
 - a. Press the Off switch from the display and then press the E-Stop button to stop the generator set. Allow the generator set to thoroughly cool to the touch.
 - b. Turn off and disconnect the battery charger from the AC source before disconnecting the battery cables.
 - c. Disconnect the negative (–) cable from the battery and secure it from contacting the battery terminals to prevent accidental starting.
2. Open the enclosure side panel to access the main circuit breaker box.
3. Place the circuit breaker handle in the OFF position.
4. Remove the bolts holding the circuit breaker cover.
5. Connect the conductors to the circuit breaker load-side terminals, neutral lug, and equipment grounding lug. For grounding and neutral connections, look for the symbols on the generator set circuit breaker box (shown below, and in the next image at the bottom).

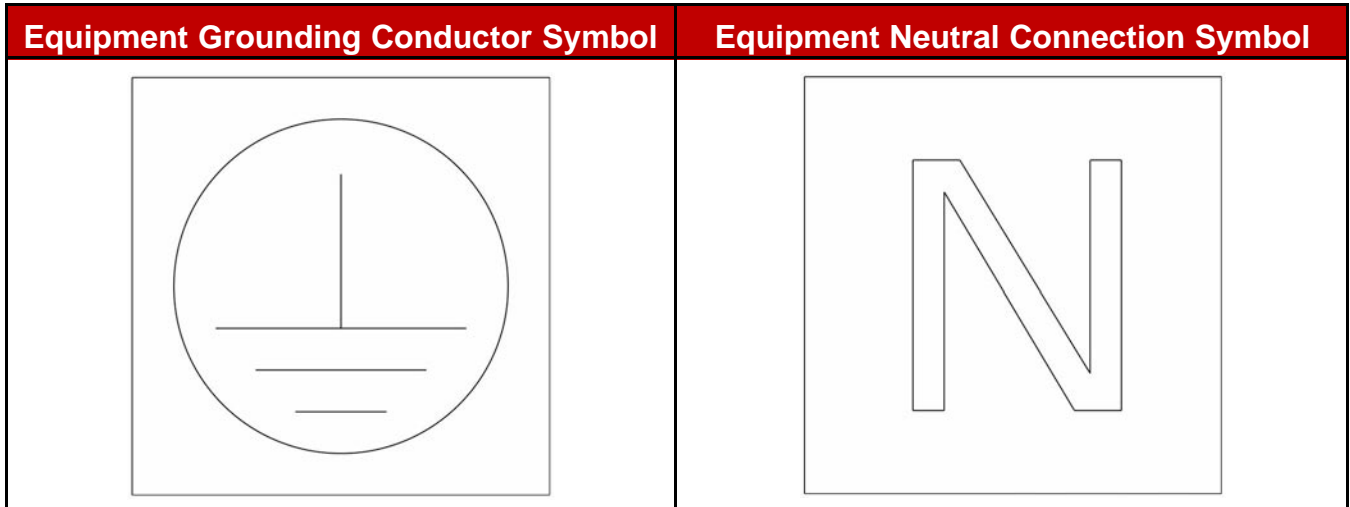

FIGURE 5. SYMBOLS ON CIRCUIT BREAKER BOX

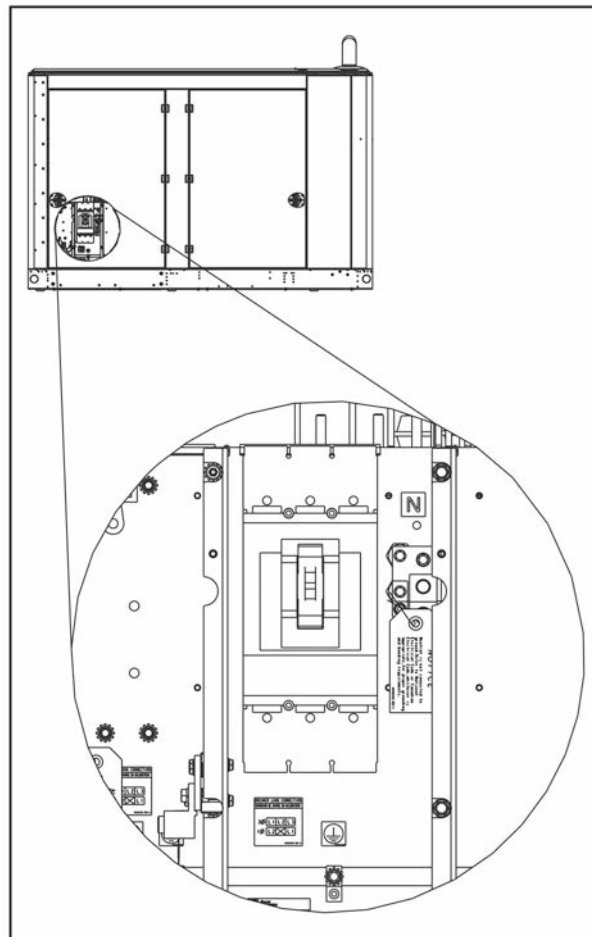

FIGURE 6. CIRCUIT BREAKER AC LOAD CONNECTIONS LOCATION (SYMBOLS SHOWN AT BOTTOM)

6. Torque the circuit breaker terminals per specifications on the circuit breaker label.

7. Torque the neutral lug per the table below:

TABLE 15. TORQUE VALUES

Wire Size	in-lb	Nm
#14 - #10	50	6
#8 - 3/0	120	14
4/0 - 350	225	26
500-600	442	50

8. Torque the equipment grounding lug per [Table 15](#).
9. Fill in the stub-up openings with an approved duct seal or mastic tape to keep out insects and rodents.
10. Install the circuit breaker cover.

Factory Option and Accessory Connections

NOTICE

Use copper conductors only.

Here are the AC powered options or accessories available:

- Alternator heater
- Battery charger
- Battery warmer
- CCV heater
- Engine coolant heater
- Oil heater

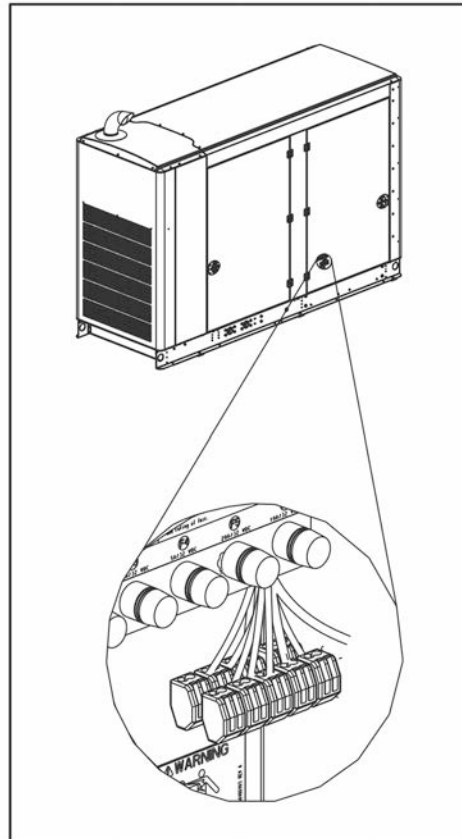

FIGURE 7. AC ACCESSORY CONNECTIONS

The alternator heater, battery charger, battery warmer, CCV heater, engine coolant heater, and oil heater require power from a 120 VAC, 20 Amp protected circuit from the main distribution panel. The high wattage coolant heater operates at 240 VAC, 15 Amp circuit. Use 12 AWG 75 °C (167 °F) conductors to make connection to the generator set AC distribution connector.

DC Connections

NOTICE

When selecting and installing conduit to the generator set, account for any needed accessories, such as a remote display, etc.

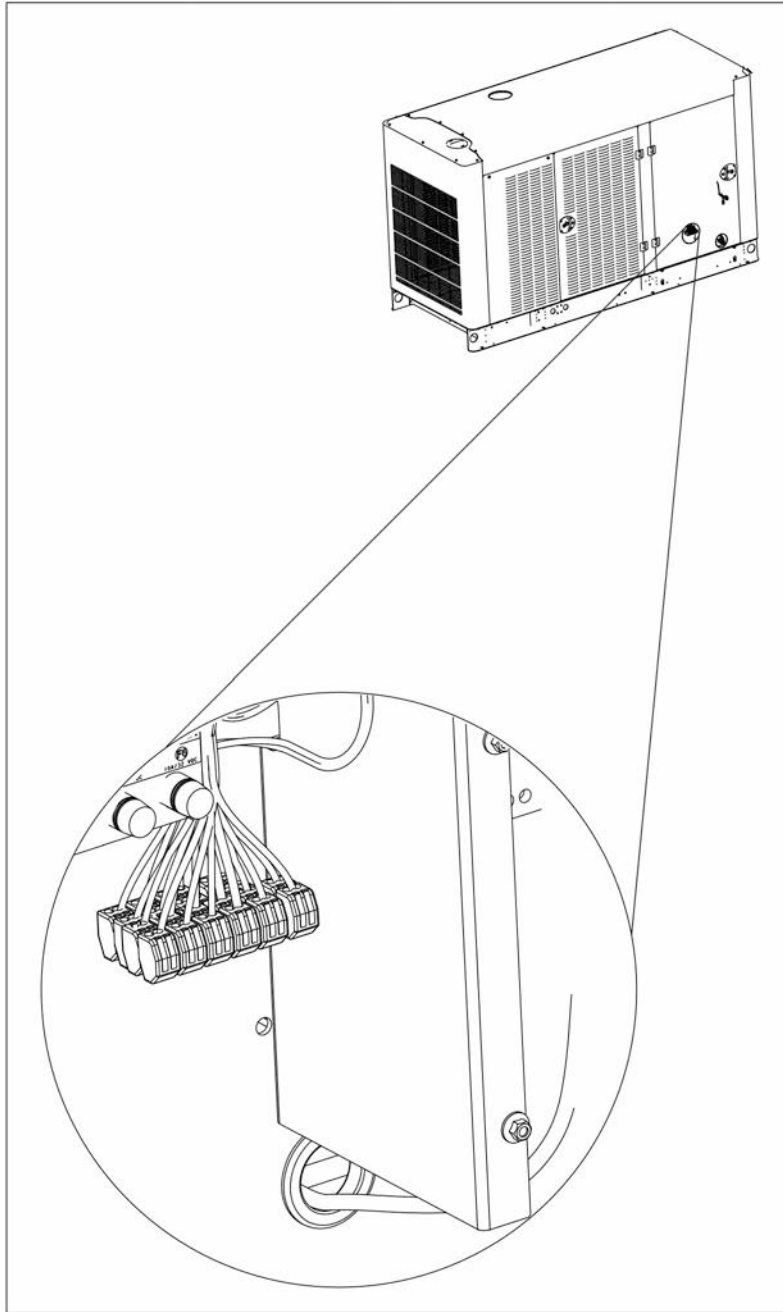

FIGURE 8. DC CUSTOMER CONNECTIONS

Grounding

NOTICE

The generator set is shipped from the factory with the neutral and equipment ground not bonded together.

Refer to local codes and standards for grounding procedures.

Battery

The generator set requires a 12V battery (negatively grounded) for engine cranking and powering the electronic control system. When the generator set is running, the battery is charged from the engine-driven battery alternator. When the set is not running, an AC powered battery charger is needed to keep the battery charged.

⚠ CAUTION

Ensure that the AC power to the battery charger is disconnected when installing the battery.

⚠ CAUTION

Wear proper safety protection when working around batteries. Keep open flames and sparks away from the equipment.

NOTICE

Only personnel knowledgeable of batteries and required precautions should perform or supervise battery servicing. Keep unauthorized personnel away from batteries.

To connect the battery:

1. Connect the positive battery terminal.
2. Connect the negative battery terminal.
3. Make sure that the battery is secured to the battery tray with the strap provided.
4. Make sure that the black and red battery cable boots are in place.

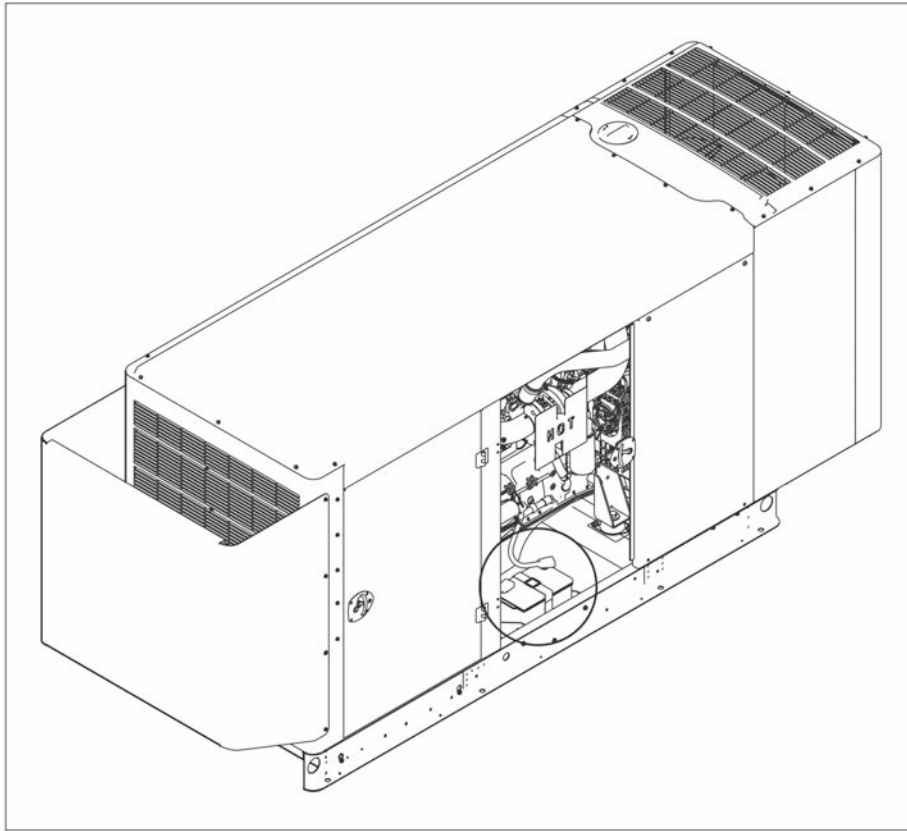

FIGURE 9. BATTERY LOCATION

Refer to the Model Specifications section for battery specifications.

An optional thermostatically controlled battery heater is available for more reliable starting in ambient temperatures below $-18\text{ }^{\circ}\text{C}$ ($0\text{ }^{\circ}\text{F}$).

To prevent injury due to accidental startup, do not connect the battery cables to the battery until the installation has been completed; tools, rags, and body parts are away from any rotating parts or electrically live parts; and it is time to start the set.

This page is intentionally blank.

5 Startup and Configuration

5.1 Operator Panel

The figure below shows the features of the front panel. It includes five lamp indicators; the graphical display with four menu select and seven menu navigation buttons; and six control mode buttons. This display panel enables the operator to look at the status, adjust the settings, and start and stop the generator set.

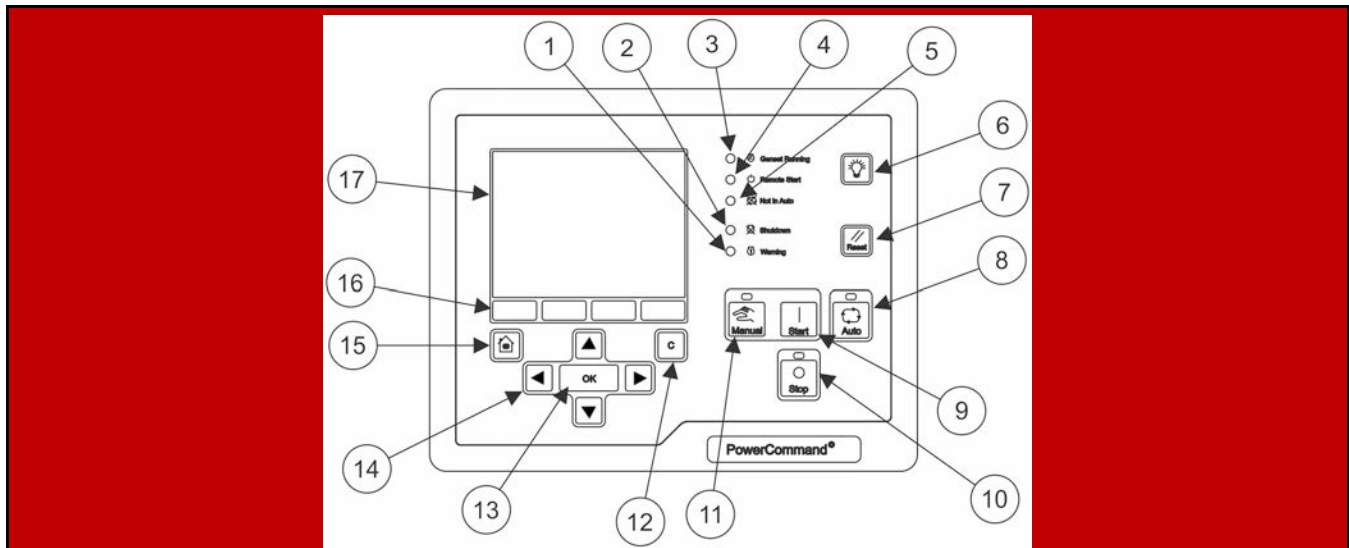

No.	Description	No.	Description
1	Indicator Lamp – Warning	10	Stop Button
2	Indicator Lamp – Shutdown	11	Manual Button
3	Indicator Lamp – Genset Running	12	Previous Menu Button (or Clear)
4	Indicator Lamp – Remote Start	13	Item Select Button (OK)
5	Indicator Lamp – Not in Auto	14	Menu Navigation Buttons (Up, Down, Left, Right)
6	Lamp Test Button/Panel Lamp On-Off	15	Home Button
7	Reset Button	16	Menu Select Buttons (for use with Item 17)
8	Auto Mode Button	17	Graphical Display
9	Start Button		

FIGURE 10. OPERATOR PANEL

Operator Panel - Initial Operator Menu

[Figure 11 on page 47](#) shows the initial menu which is displayed over two pages. Use the soft-key buttons below the up and down arrows (▲ and ▼) to toggle between the two pages.

Use the soft-key buttons below Genset, Alternator, or Engine to short-cut to those menus.

Pressing the **Home** button  from any screen will return the display to the main menu screens.

Initial Menu Data

This menu displays the information available through the menus.

TABLE 16. INITIAL DATA MENU

Name	Description	
History/About	Use this screen to view historical information about your generator set.	
Faults:	If there are no active Faults, these screens will not be available.	
	Active Shutdowns	Use this screen to view active Shutdown faults.
	Active Warning	Use this screen to view active Warning faults.
	History	Use this screen to view faults that have been cleared.
Genset Data	Use this screen to view the status of the generator set.	
Alternator Data	Use this screen to view the status of the alternator.	
Engine Data	Use this screen to view the status of the engine.	
Advanced Status:	---	
	Genset	Use this screen to view power, energy, phase difference, and other detailed generator set information.
	Controller	Use this screen to view sequences of operation, configurable inputs and outputs, and other detailed controller information.
	Engine	Use this screen to view pressures, voltages, temperatures, and other detailed engine information.
Help	Use this screen to obtain more information regarding the operator panel.	

Name	Description
Adjust	The use of these screens is restricted to authorized personnel only.
Genset Setup	
Paralleling Basic Setup	
OEM Setup	
PCCnet Setup	
Modbus Setup	
Display Options	
Clock Setup	
Configurable IO	
Calibration	
Save/Reserve	

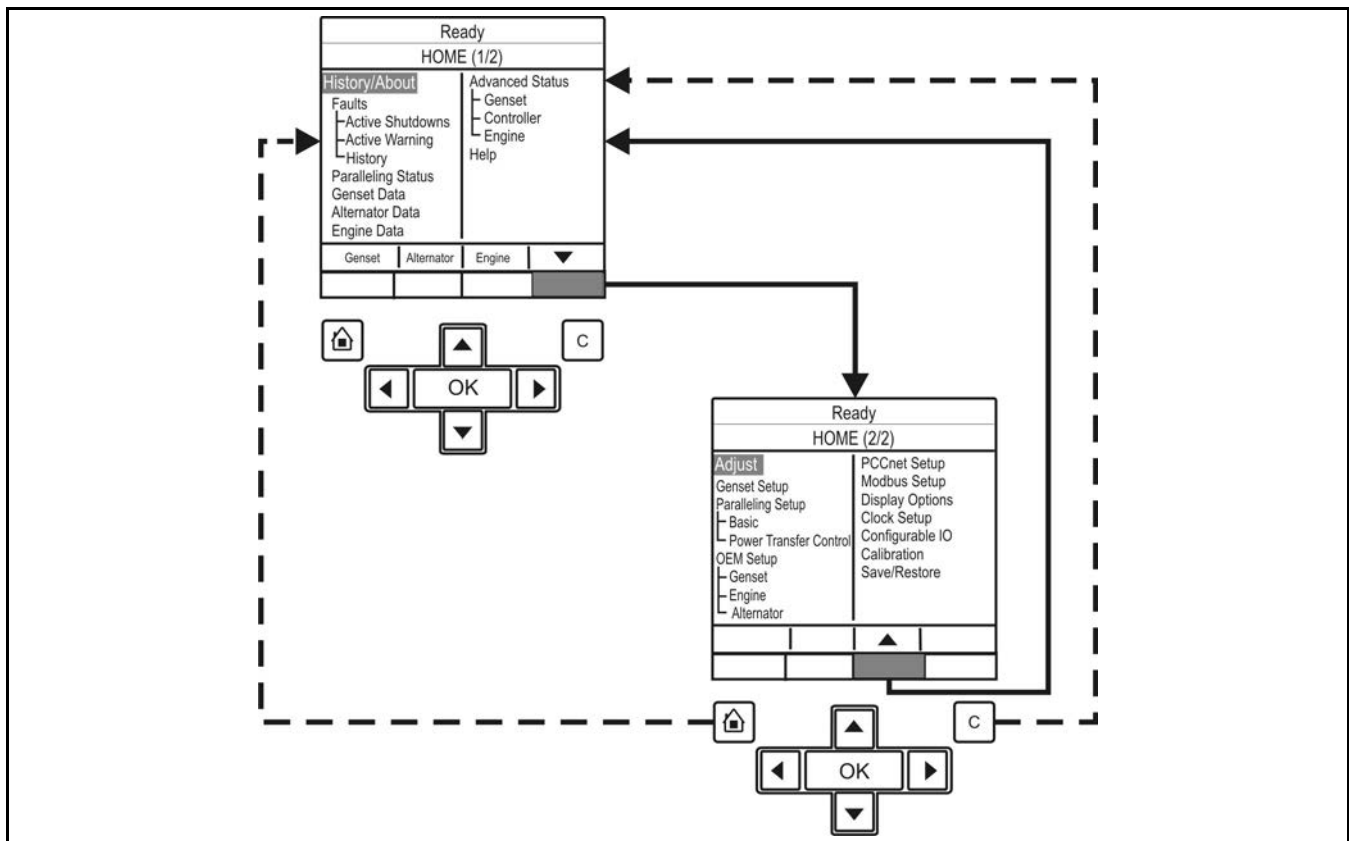



FIGURE 11. INITIAL OPERATOR MENU

- Press the **Home** Button  to return to the main menu at any time.

- Press the **C** Button  to return to the previous menus. Settings will not be saved when this button is pressed.

Operator Panel - Engine Data Operator Menu

The Engine Data Menu - Typical Data figure shows a block representation of a typical Engine Data menu. To navigate from the Home menu (HOME [1/2]), press the soft-key button below the function button indicating Engine. This will take you directly to the Engine menu.

The Engine Data menu is displayed on one page.

Engine Data Menu

Use this menu to look at the status of the engine.

TABLE 17. ENGINE DATA MENU

Name	Description	Allowed Values
Pressure		
Oil	Monitor point for Oil Pressure	0 - ~993 kPa (0 - ~145 psi)
Boost	Monitor point for Boost Absolute Pressure	0 - ~1014 kPa (0 - ~148 psi)
Fuel Rail	Monitor point for Fuel Outlet Pressure	0 - ~249364 kPa (0 - ~36404 psi)
Fuel Inlet	Monitor point for Fuel Supply Pressure	0 - ~993 kPa (0 - ~145 psi)
Coolant	Monitor point for Coolant Pressure	0 - ~993 kPa (0 - ~145 psi)
Crankcase	Monitor point for Crankcase Pressure	-244 - ~260 kPa (-35.67 - ~38 psi)
Ambient	Monitor point for Barometric Absolute Pressure	0 - ~253 kPa (0 - ~37 psi)
Temperature		
Coolant	Monitor point for Coolant Temperature	N/A
Oil	Monitor point for Oil Temperature	-40 - ~210 °C (-40 - ~410 °F)
Manifold	Monitor point for Intake Manifold Temperature—	-40 - ~210 °C (-40 - ~410 °F)
Fuel Inlet	Monitor point for Fuel Temperature	-40 - ~210 °C (-40 - ~410 °F)
Aftercooler	Monitor point for Aftercooler Temperature	-40 - ~210 °C (-40 - ~410 °F)
Other		
Engine Hrs	Total engine run time	
Engine Speed	Monitor point for Average Engine Speed	

Name	Description	Allowed Values
Batt Voltage	Battery voltage value	

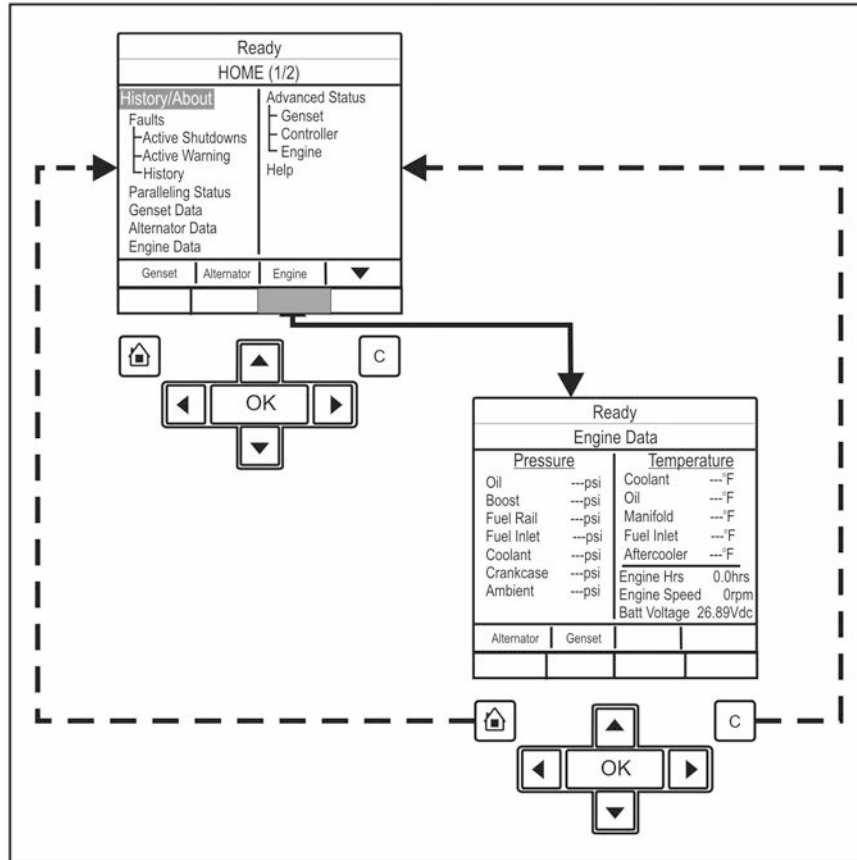



FIGURE 12. ENGINE DATA MENU - TYPICAL DATA

- Press the **Home** Button  to return to the main menu at any time.
- Press the **C** Button  to return to the previous menus. Settings will not be saved when this button is pressed.

History/About Menu

[Figure 13 on page 51](#) shows a block representation of a typical History/About menu.

To navigate from the Home menu, toggle down until the History/About line of text is highlighted, and press the OK button. This information is displayed over three pages. Use the two soft-key buttons below the up and down arrows (▲ and ▼) to toggle between the pages.

This screen displays the historical information about the generator set.

TABLE 18. HISTORY/ABOUT MENU

Name	Description
Starts	Total number of start attempts.
Runs	Total number of generator set runs.
Engine Hours	Total engine run time.
Control Hours	Controller ON time in seconds. Upper limit is 136 years.
Kw Hours	Generator set total net kWh accumulation.
Gen Mod #	Number identifying the model of the generator set. (Password level: 2)
Gen Ser #	Serial number identifying the generator set.
Nominal Voltage	Generator set nominal Line-to-Line voltage.
Wye/Delta	Delta or Wye for Generator set connection.
Rating Select	Selects Standby/Prime/Base application rating.
Contr Type	Used by the PC tool.
Firmware Ver	Version of software loaded into the control. Obtained from PowerCommand® 2.3 Filename.
Calib Part	The unique calibration part number loaded into the control.
Calib Date	The revision date of the calibration part number loaded into the control.
ECM Code	The calibration coded the ECM is sending.
HMI Firm Ver	Parameter: HMI Local Parameter.
HMI Boot Ver	Parameter: HMI Local Parameter.
50 Hz Load Profile*	This shows how long the generator set has been running (50 Hz operation) at various percentages of its rated load.
60 Hz Load Profile*	This shows how long the generator set has been running (60 Hz operation) at various percentages of its rated load.
* When using the Load Profile Graph table (for 50 Hz or 60 Hz), the upper line's value indicates 100% of table.	

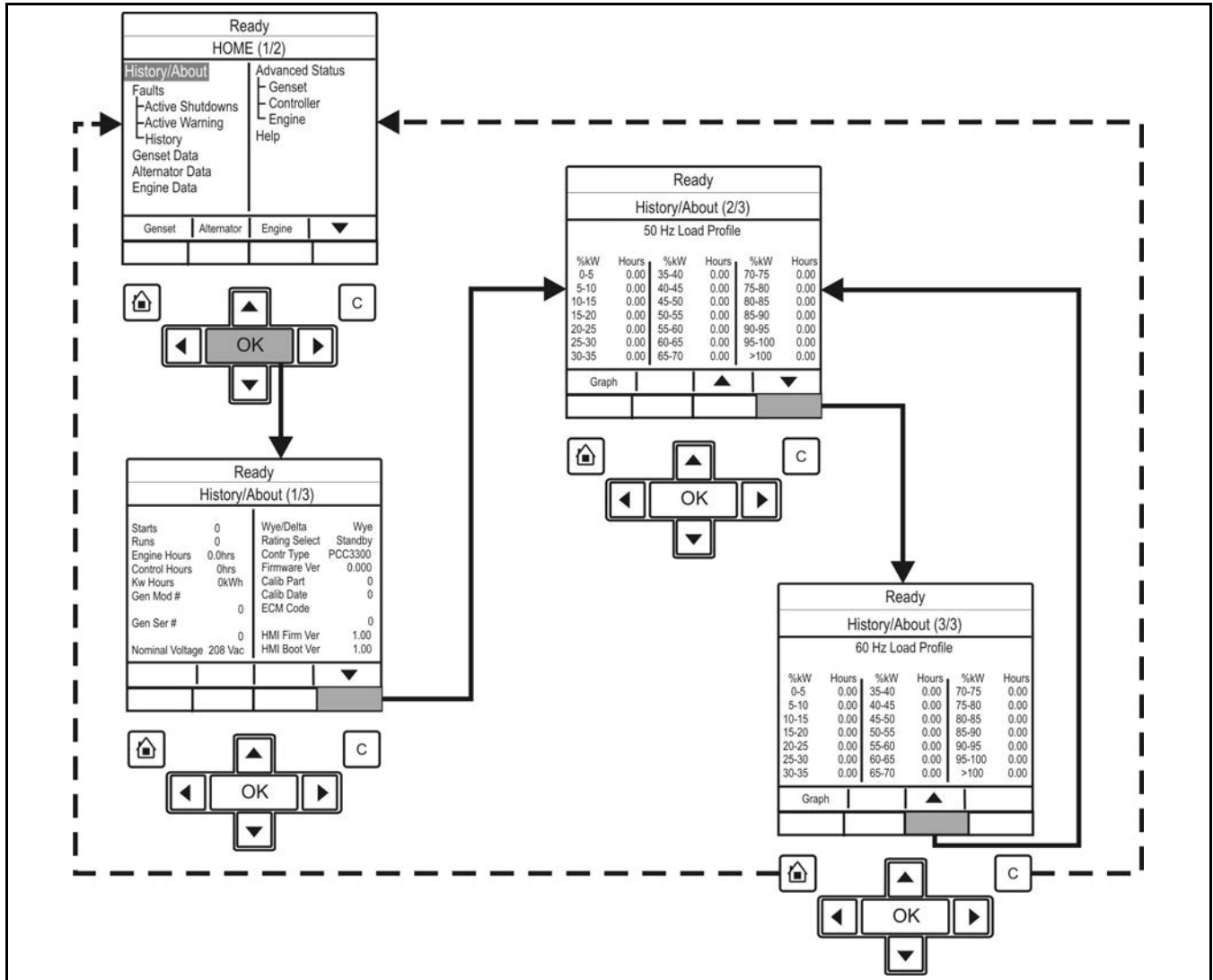



FIGURE 13. HISTORY/ABOUT MENU - TYPICAL DATA

- Press the **Home** Button  to return to the main menu at any time.
- Press the **C** Button  to return to the previous menus. Settings will not be saved when this button is pressed.

Contrast

The Display Options screen allows the contrast to be set.

1. From any Information screen, hold down the up and down arrows simultaneously for two seconds to gain access to the Service Menu screen.
2. Select **Display Options**.
3. From the Display Options screen, select **Adjust** to access the screen variables.
4. Press the right arrow to move to the Contrast variable.

5. Adjust the setting and press **Save** to save any changes. When updating this setting, the functions of the keys are as follows:

TABLE 19. KEY FUNCTIONS ON THE DISPLAY OPTIONS SCREEN

Key/Button	Function
Horizontal right arrow key	Select successive blocks for editing settings on the screen
Left arrow key	Return to the previous screen
+ or - keys	Adjust values on the Adjust screen of the Display Setup screen
Save button	Save any changes; after saving, the Save button changes to the Adjust button

NOTICE

The following screen represents the standard view. If using a remote operator panel, which may be purchased as an option, the screen may look slightly different. This procedure applies to both operator panels.

Rated frequency and voltage			
Display Options			
Power mgmt	Min	<u>Units</u>	
Language	English	Temperature	
Backlight timer	Sec	Fluid Pressure	
Sleep timer	Sec	Gas Pressure	
Sleep mode	–	Fluid Flow	
Contrast	8	Fluid Volume	
Mode Change	–		
Clock			

FIGURE 14. DISPLAY OPTIONS SCREEN

Updating Daylight Saving Adjust Screens

Update Values on the Daylight Saving Adjust Screen

1. From any Information Menu, hold down the up and down arrows simultaneously for two seconds. The Service Menu appears.
2. Navigate to the Genset Service Menu.

3. Select **Clock Exerciser** to access the Time Setup screen.
4. Press the down key on the Time Setup screen to access the Daylight Saving Adjust screen.
5. Select **Adjust**. When updating these settings, the functions of the keys are as follows:

TABLE 20. KEY FUNCTIONS ON THE DAYLIGHT SAVING ADJUST SCREEN

Key/Button	Function
Horizontal right arrow key	Select successive blocks for editing settings on the screen
Left arrow key	Return to the previous screen
+ or - keys	Adjust values on the Adjust screen of the Daylight Saving Adjust screen
Save button	Save any changes; after saving, the Save button changes to the Adjust button

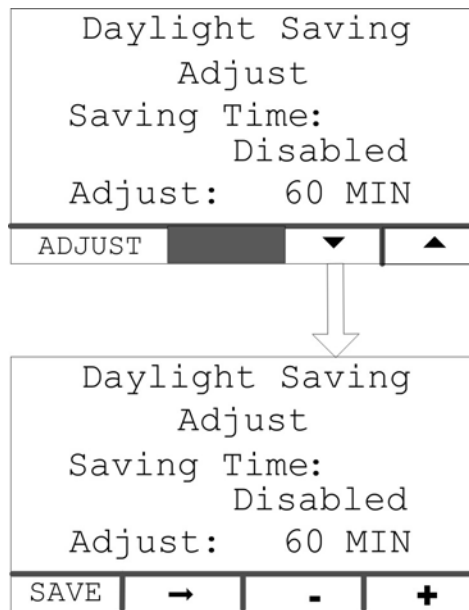

FIGURE 15. "DAYLIGHT SAVING ADJUST SAVING TIME" SCREEN NAVIGATION

Access and Update the Daylight Saving Adjust Start Screen

1. Press the down arrow key on the Daylight Saving Adjust screen.
2. Press **Adjust**. When updating these settings, the functions of the keys are as follows:

TABLE 21. KEY FUNCTIONS ON THE DAYLIGHT SAVING ADJUST START SCREEN

Key/Button	Function
Horizontal right arrow key	Select successive blocks for editing settings on the screen
+ or - keys	Adjust Month, Week, Day or Hour
Save button	Save any changes; after saving, the Save button changes to the Adjust button

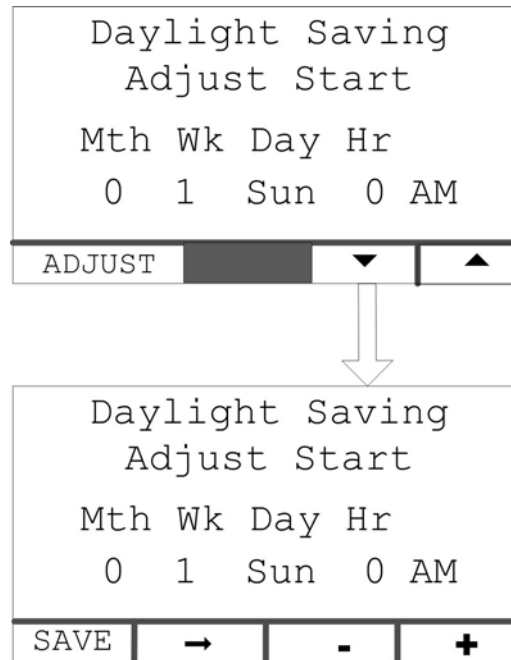

FIGURE 16. DAYLIGHT SAVING ADJUST START SCREEN

Update the Daylight Saving Adjust End Screen

1. Press the down key on the Daylight Saving Adjust Start screen.
2. Press **Adjust**. When updating these settings, the functions of the keys are as follows:

TABLE 22. KEY FUNCTIONS ON THE DAYLIGHT SAVING ADJUST END SCREEN

Key/Button	Function
Horizontal right arrow key	Select successive blocks for editing settings on the screen
+ or - keys	Adjust Month, Week, Day or Hour
Save button	Save any changes; after saving, the Save button changes to the Adjust button

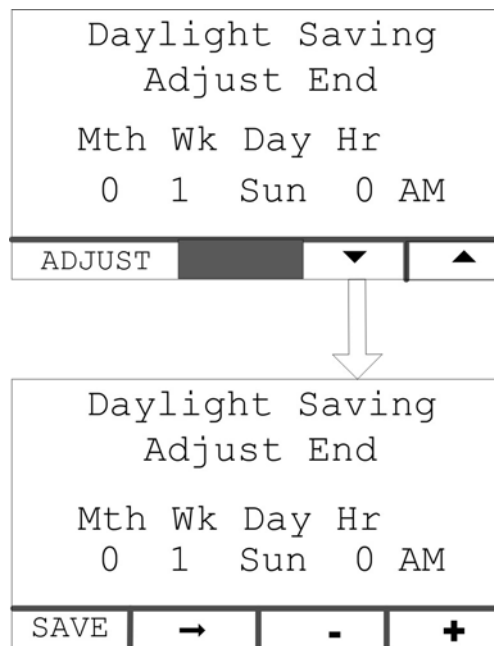

FIGURE 17. DAYLIGHT SAVING ADJUST END SCREEN

Genset Setup Menu

Use the Genset Setup menu to view generator setup data. The figure below shows block representations of the Genset Setup menu and sub-menus.

1. Use the two soft-key buttons below the up and down arrows (▲ and ▼) to page down to the second page of the HOME (2/2) menu.
2. In the HOME (2/2) menu, use the up and down arrows (▲ and ▼), to highlight the Genset Setup text.
3. With the Genset Setup text highlighted, press the **OK** button. This will display the Setup Genset menu.
4. Use the two soft-key buttons below the up and down arrows (▲ and ▼) to page through the five pages of generator setup data.

NOTICE

If any of these settings need to be changed, please contact your authorized service center.

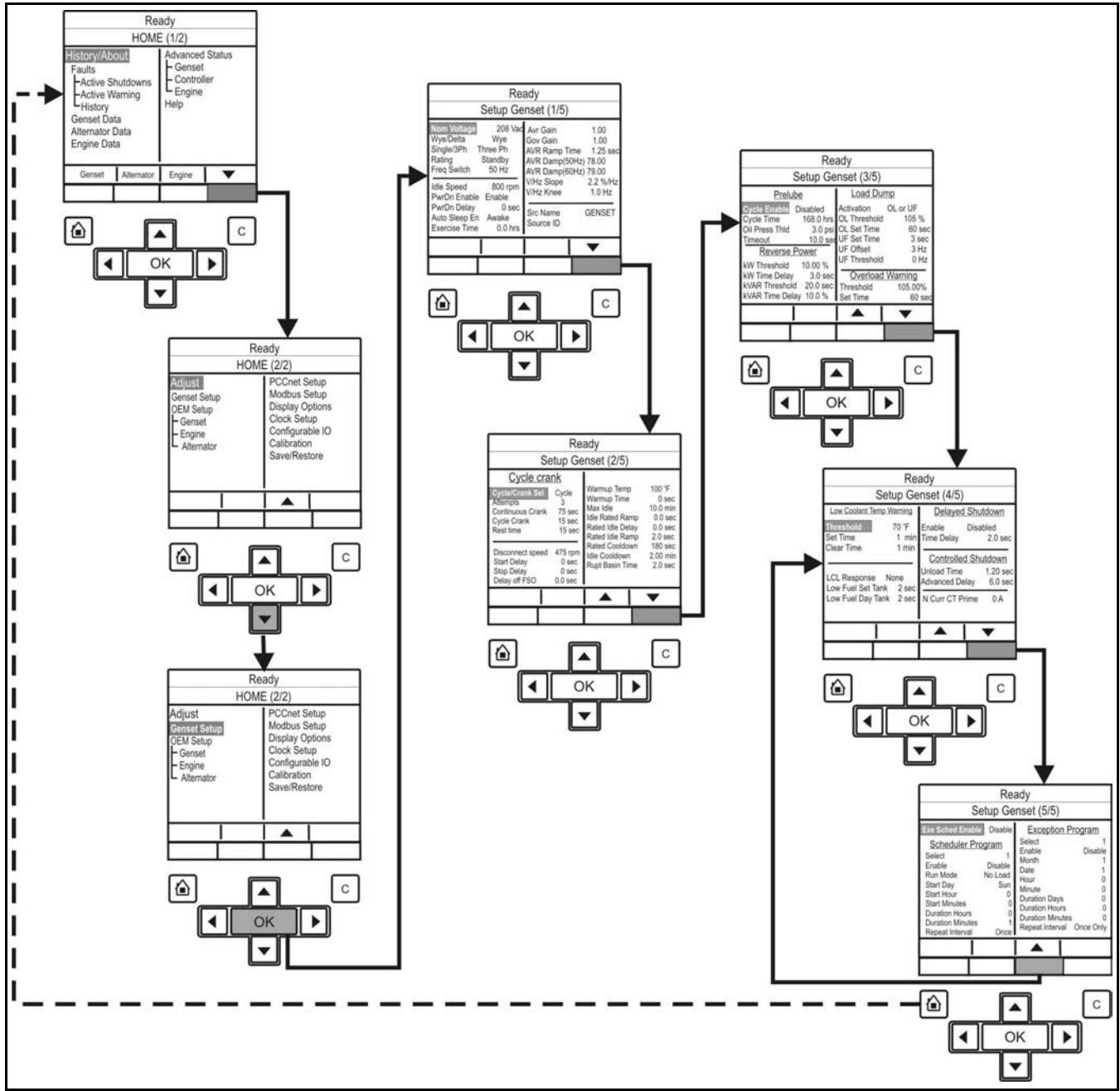

Press the **Home** Button to return to the main menu at any time.

Press the **C** Button to return to the previous menus. Settings will not be saved when this button is pressed.

FIGURE 18. GENSET SETUP MENU - TYPICAL DATA

5.2 Checklist

Tick	Item
	General
	Generator set output is sufficient to handle maximum anticipated load.
	At least 0.9 m (3 feet) of clearance (or greater for housing door) is provided around the entire generator set for service and ventilation.
	The generator set is located in an area not subject to flooding.
	All operating personnel have read and are familiar with the generator set operator manual, all health and safety procedures, warnings, cautions, precautions, and the other documentation supplied with the generator set.
	All operators have been thoroughly briefed on preventative maintenance procedures.
	All operators have read and understand all important safety instructions.
	Any parts requiring software have been checked for the latest version. Contact the service representative for more information.
	Generator Set Position
	The floor, roof, or earth on which the generator set rests is strong enough and will not allow shifting or movement. Observe local codes on soil bearing capacity due to freezing and thawing.
	The generator set is properly supported and retained to an approved base.
	The supporting base is large enough and is of non-combustible material, extending 15 cm (6 inches) all around the generator set.
	Provisions have been made for site specific environmental operating conditions (weather protection, proximity to coastline, dusty environments, etc.,)
	Cooling Air Flow
	Generator set air inlet is faced into the direction of strongest, prevailing winds.
	Air inlet openings are unrestricted and are at least 1 to 1½ times larger than air outlet area.
	Cooling air outlet is on downwind side of building (if not, a wind barrier is constructed).
	Proper ducting material (sheet metal, canvas) is used between radiator and air outlet.
	Fuel System
	Fuel lines are properly installed, supported, and protected against damage.
	The fuel filters have been installed.
	Approved flexible fuel line is installed between the main fuel supply and the generator set's fuel system near the generator set, to protect it against damage caused by vibration, expansion, and contraction.
	Fuel supply shutoff valves are installed to prevent fuel flow in case of leaks.

Tick	Item
	No fuel leaks are found in supply line or engine fuel system.
	Check fuel line and use equations to verify it has proper volume capability.
	Check if fuel pressure is between 1.5 - 3.2 kPa (6 - 13 inches water column) under any condition.
	Make sure fuel pressure does not drop below 1.5 kPa (6 inches water column) under full load.
	If necessary, perform initial demand regulator adjustment procedure.
	Exhaust System
	The breather tube routing is set up to blow the fumes away from the generator set (if applicable)
	Operators are thoroughly briefed on the dangers of carbon monoxide gas.
	If the installation includes a heavy duty air cleaner, it has been installed.
	Areas around generator set are well ventilated, with no possibility of exhaust fumes entering building doors, windows, or intake fans.
	Exhaust gases are piped safely outside and away from building.
	The correct length of approved rigid pipe is connected to the generator set flexible pipe using approved securing methods with no weight resting on engine exhaust components. There are no bends in flex section.
	Condensation drain is provided in lowest section of exhaust piping.
	Exhaust piping is insulated to guard against burns to personnel.
	Exhaust piping passing through walls or ceilings have approved fire-proof materials and are in compliance with all codes.
	Exhaust piping is large enough in diameter to prevent excessive back pressure on engine.
	AC and DC Wiring
	Wire sizes, insulation, conduits and connection methods all meet applicable codes.
	AC and DC wires are separated in their own conduit to prevent electrical induction.
	All load, line and generator connections are well made and correct.
	Flexible conduit is used between the generator and the building or surrounding structure.
	Check phase rotation.
	Generator Set Pre-Start
	Generator set engine is properly serviced with oil and coolant.
	Battery charger is installed using the appropriate cable size and is operational.

Tick	Item
	Battery charger is configured for the proper DC battery voltage, battery type, and float voltage.
	Batteries are properly installed, serviced and charged.
	Cooling system is filled with correct volume and concentration of coolant. The water used in the coolant mix has passed water quality check.
	Engine coolant heater (if applicable) is connected and operational.
	All generator set covers and safety shields are installed correctly.
	All fuel and coolant shutoff valves are operational.
	Shipping brackets are removed.
	Radiator fan and other external moving parts, including drive belts, are unrestricted.

5.3 Before Starting

NOTICE

One operator should be in complete charge, or working under the direction of someone who is in charge. Remember that, upon starting the engine, cables and switchgear will become energized, possibly for the first time. Furthermore, equipment that does not form part of the generator set installation may become electrically charged. Only authorized and competent personnel should carry out this work.

NOTICE

Do not use the Emergency Stop button to shut down an engine unless a serious fault develops. The Emergency Stop button must not be used for a normal shut-down as this will prevent a cooling down run in which the lubricating oil and engine coolant carry the heat away from the engine combustion chamber and bearings in a safe manner.

NOTICE

***Diesel engines only:* Avoid off-load running for other than short periods. A minimum loading of 30% is recommended. The engine must be shut down as soon as possible after the appropriate functions have been checked.**

NOTICE

***Gaseous engines only:* Avoid running the generator set at no-load and light-loads for extended periods.**

Before attempting to start the generator set, the operator should read through this entire manual and the specific literature provided as part of the documentation pack supplied with the generator set. It is essential that the operator be completely familiar with the generator set and the PowerCommand® control.

The sub-sections below cover the systems used to start and stop the generator set.

Before starting the generator set, make sure that exhaust and fuel fittings are tight and properly positioned, and that proper maintenance and pre-start checks have been performed.

During starting, automatic checks are carried out for the integrity of various protection systems. The PowerCommand® control will not allow the generator set to continue the starting sequence if the integrity of a sensor is considered to be in doubt.

The generator set can be configured for a number of starting cycles (one to seven) with set times for crank and rest periods for all starting modes (manual/remote). The default setting is for three start cycles, composed of fifteen seconds of cranking and 30 seconds of rest.

NOTICE

The number of starting cycles, and the crank and rest times are set from within the Setup menu. Trained and experienced service personnel are required to change the default setting. Contact your authorized Cummins distributor.

Initial Pre-Start Checks

WARNING

Electric Shock Hazard

Voltages and currents present an electrical shock hazard that can cause severe burns or death.

Make sure that only personnel who are trained and experienced work with distribution voltages. Even after generator set shutdown, an electrical shock hazard may still exist, caused by induced or residual voltage within the alternator or cables. Some interfaces may display zero voltage even when voltages are present.

WARNING

Hot Pressurized Liquid

Contact with hot liquid can cause severe burns.

Do not open the pressure cap while the engine is running. Let the engine cool down before removing the cap. Turn the cap slowly and do not open it fully until the pressure has been relieved.

Before starting, competent personnel must make the following checks to make sure that the unit is ready for operation:

TABLE 23. INITIAL PRE-START CHECKS

Check	Description
Generator Set Grounding	Grounding (earthing) must be checked prior to performing service or inspection procedures that may expose personnel to conductors normally energized with voltages greater than 600 Volts. Contact your authorized Cummins distributor.
Insulation Testing ¹	This must be performed on all generator sets before initial start-up and after the generator set grounding procedure has been completed. Insulation testing for low voltage (less than 600 Volts) generator sets is recommended by Cummins. These tests are used to verify that the windings are dry before the generator set is operated, and to develop a base line for future test comparisons. Contact your authorized Cummins distributor.
Lubrication ²	Check the engine lubrication oil level and ensure that the correct level is always maintained.
Coolant ^{3,4,5}	Check the engine coolant level and ensure that the level is always maintained. Fill the cooling system to the bottom of the fill neck in the radiator fill or expansion tank. Do not check the level while the engine is hot.

¹When wire insulation-testing an alternator, failure to protect the voltage regulator, control and diodes could result in permanent damage to one or more of the electronic components.

²*Generator sets shipped dry only:* They must be filled with the correct type and quantity of oil before use. Be sure to check the oil level before initial start. Failure to fill to the recommended level can result in equipment damage.

³*Generator sets that require a mix of anti-freeze and DCA inhibitor only:* You must comply with Cummins requirements for the correct type and concentration of anti-freeze and DCA inhibitor. Warranty claims for damage will be rejected if the incorrect mix is used. Consult your authorized Cummins distributor for the correct anti-freeze specifications and concentration for your operating conditions.

⁴*Radiators with two fill necks only:* Both fill necks must be filled after the cooling system has been drained.

⁵*Generator sets shipped dry only:* The engine must be filled with the correct type and quantity of coolant before use. Be sure to check coolant level(s), before the initial start.

Operator’s Pre-Start Checks

WARNING

Arc Flash and Shock Hazard
Electric arc flash can cause electrical shock, severe burns, or death.
Make sure the alternator is dry before the generator set is operated.

⚠ WARNING***Hot Pressurized Liquid******Contact with hot liquid can cause severe burns.******Do not open the pressure cap while the engine is running. Let the engine cool down before removing the cap. Turn the cap slowly and do not open it fully until the pressure has been relieved.*****NOTICE*****Radiators with two fill necks only: Both fill necks must be filled when the cooling system has been drained.*****TABLE 24. OPERATOR'S PRE-START CHECKS**

Check	Description
Fuel Supply (Diesel Only)	<p>Make sure that:</p> <ul style="list-style-type: none"> • The fuel tank is filled to the normal level with clean water-free fuel and that the fuel system is primed; • All the valves required for operation are open; and • There are no leaks and that all fittings are tight.
Lubrication	With the engine stationary, check the engine lubrication oil level and make sure that the correct level is always maintained.
Coolant	Check the engine coolant level and make sure that the level is always maintained at the coolant expansion tank. Fill the cooling system to the bottom of the fill neck in the radiator fill or expansion tank. Do not check while the engine is hot.
Cooling Air Inlet/Outlets	Make sure that the cooling air inlets/outlets are unobstructed.
Exhaust Outlet	<p>Make sure that:</p> <ul style="list-style-type: none"> • Exhaust components are secured and not warped; • The exhaust outlet is unobstructed; • No combustible materials are near the system; • Gases are discharged away from building openings; and • There are no leaks and that all fittings are tight.
Batteries	Make sure that the batteries are charged, and that all connections are clean, correct and tight (if applicable).
Auxiliary Powered AC Supplies	Make sure that all auxiliary equipment is receiving power from the customer's supply.
Emergency Stop	Make sure that the emergency stop button is fully operational.

Starting at the Operator Panel (Manual Run Mode)

NOTICE

Make sure that all Pre-start Checks are carried out before starting the generator set. Do not attempt to start the generator set until it is safe to do so. Warn all others in the vicinity of the generator set and connected load equipment that the generator set is about to start.

STARTING IN MANUAL RUN MODE

1. Make sure the main circuit breaker is in the open position.
2. To start the generator set in the **Manual Run** mode:

a. Press the **Manual** button  on the operator panel.

b. Press the **Start** button  within ten seconds.

NOTICE

Failure to press the Start button within this time will result in the generator set changing to the Off mode. Refer also to the Selecting Manual Run Mode section.

NOTICE

If the mode change access code feature has been enabled, enter the access code when prompted. See the Passwords and Mode Change Access section.

3. The PowerCommand[®] control will initiate a starter cranking signal and will perform an automatically sequenced manual start, under a complete engine protection system combined with full monitoring capability. This will activate the engine control system and the starting procedure. The starter will begin cranking and, after a few seconds, the engine will start and the starter will disconnect.

If the engine fails to start, the starter will disengage after a specified period of time and the control will indicate a Fail to Start shutdown.

To clear a Fail to Start shutdown:

a. Press the **Stop** button. 

b. Press the **Reset** button. 

4. Before attempting to re-start, wait a minimum of two minutes for the starter motor to cool and then repeat the starting procedure. If the engine does not run after a second attempt, refer to the Troubleshooting section of the operator manual.

DISABLING MANUAL MODE

To disable Manual mode, change to **Auto** or **Off** mode. If the generator set is running when it leaves **Manual** mode, it will continue to run if **Auto** mode has been selected and the remote start signal is active. If there is no active remote start signal, the generator set will stop.

Starting from Remote Location (Auto Mode)

NOTICE

Make sure that all Pre-start Checks are carried out before starting the generator set. Do not attempt to start the generator set until it is safe to do so. Warn all others in the vicinity that the generator set is about to start.

1. To start the generator set in the **Auto Run** mode, select the **Auto** button from



the operator panel. Refer also to the Selecting Auto Mode section.

Once the PowerCommand® control receives a remote start signal, and after a Time Delay to Start, the control will initiate the starting sequence as above. The Remote Start LED will be lit.

NOTICE

If the mode change access code feature has been enabled, enter the access code when prompted. See the Passwords and Mode Change Access section.

NOTICE

When the generator set is operating in the Remote Start mode, removing the Remote Start command does not shut off the engine if the load is more than 10%, the cooldown timer is set to zero, and the control is configured for a single unit (not in parallel). The generator set continues to operate until it runs out of fuel, the E-stop button is used, or the load is removed.

2. To disable **Auto** mode, change to **Manual** or **Off** mode.

Cold Starting with Loads

NOTICE

Make sure that all pre-start checks are carried out before starting the generator set. Do not attempt to start the generator set until it is safe to do so. Warn all others in the vicinity that the generator set is about to start.

Use a coolant heater if a separate source of power is available. The optional heater available from Cummins will help provide reliable starting under adverse weather conditions. Be sure the voltage of the separate power source is correct for the heater element rating.

Cummins recommends equipping standby generator sets (life safety systems) with engine water jacket coolant heaters to maintain the coolant at a minimum of 32 °C (90 °F) and, for most applications, accept the emergency load in ten seconds or less. Although most Cummins generator sets will start in temperatures down to -32 °C (-25 °F) when equipped with engine water jacket coolant heaters, it might take more than ten seconds to warm the engine up before a load can be applied when ambient temperatures are below 4 °C (40 °F).

The **Low Coolant Temp** (Code 1435) message along with the lighting of the **Warning** LED are provided to alert the operator of a possible delay in accepting the load. The engine cold sensing logic initiates a warning when the engine water jacket coolant temperature falls below 21 °C (70 °F). In applications where the ambient temperature falls below 4 °C (40 °F), a cold engine may be indicated even though the coolant heaters are connected and functioning correctly. Under these conditions, although the generator set may start, it may not be able to accept load within ten seconds. When this condition occurs, check the coolant heaters for correct operation. If the coolant heaters are operating correctly, other precautions may be necessary to warm the engine before applying a load.

Checking Coolant Heater Operation

WARNING

Hot Surfaces

Contact with the hot surfaces can cause severe burns.

Avoid contact with hot parts. Allow hot parts to completely cool.

Do not touch the cooling system outlet hose. The coolant heater is operating if radiant heat can be felt with your hand held close to the outlet hose and the engine is not running.

5.4 Startup

WARNING

Automated Machinery

Accidental or remote starting of the generator set can cause severe personal injury or death.

Isolate all auxiliary supplies and use an insulated wrench to disconnect the starting battery cables, negative (-) cable first.

- After verifying that the installation was completed correctly, start and test the system. Make sure to connect the battery cables to the battery with the positive (+) cable first.

-
- Read through the operator manual and perform the maintenance and pre-start checks as instructed.
 - *The following information applies to C125 N6 and C150 N6 generator set models only:* Adaptive learn is an engine ECM function that allows the generator set to "learn" its environment. There are small differences in the performance of each engine and fuel system component, so the ECM uses inputs from the engine sensors to adjust running conditions to operate more consistently for each individual generator set.

After installation is complete and while testing the overall system function, you must run the generator set with no active faults under load (that is, with the transfer switch connected to maximum customer load available) until the engine temperature reaches 65.5 °C (150 °F) to allow the adaptive learn function to initialize.

- The generator set is shipped from the factory with the proper level of engine oil and coolant, but make sure to check each before starting the generator set.
- Start and operate the generator set following all the instructions and precautions in the operator manual.
- Before leaving the site:
 - Ensure that the bonding bolts are installed into the service panels.
 - If the generator set is ready to be placed in service, put the generator set in Auto mode to provide automatic standby power.
 - Make sure the circuit breakers are in the ON position.

NOTICE

Contact your local Cummins service representative if you encounter a fault code.

Appendix A. Fuel Line Selection

Table of Contents

Table 26. Required Information for Determining Fuel Line Size 68

Table 28. NFPA Equivalent Lengths of Pipe Fittings and Valves in Feet (Meters) 69

Table 30. Natural Gas Schedule 40 Metallic Pipe Sizing in Inches 70

Table 33. Natural Gas Semirigid Copper Tubing Sizing 72

A.0 Fuel System Pipe Sizing Introduction

Incorrect fuel line size may cause the generator set to not run or provide full power output.

Tables are included in this section to help calculate pipe sizing for natural gas under specified conditions. Consult NFPA 54 or other applicable codes for other operating conditions or other fuel system installation requirements.

Refer to the *Engineering Application Manual T-030: Liquid Cooled Generator Sets* manual (A040S369) for more information.

To determine the optimal fuel line size, the following information is needed:

TABLE 26. REQUIRED INFORMATION FOR DETERMINING FUEL LINE SIZE

Category	Description
Fuel Flow Requirements for the Generator Set	Fuel flow requirements have a large impact on fuel line size.
Fuel Source (Natural Gas)	Fuel sources can affect fuel line size.
Fuel Line Length (Including Fittings)	As fuel line lengths increase, they may require larger diameter fuel lines. Be sure to consider the equivalent length of all of the fittings (elbows, tees, valves) in the installation in addition to the straight pipe length.
Fuel Line Type (e.g., Copper Tubing or Iron Pipe)	Most fuel line types are iron pipe or copper tubing. Be sure to use the sizing chart for the fuel line type when sizing the fuel line.

NOTICE

NFPA 54 has selection tables for other approved fuel lines. Verify with the authorities having jurisdiction the allowed fuel line type for the generator set installation.

A.1 Gas Pipe Sizing

NOTICE

The following tables in this section are reprinted with permission from NFPA 54-2015, *National Fuel Gas Code*, Copyright © 2014, National Fire Protection Association.

- Natural Gas Schedule 40 Metallic Pipe Sizing
- Natural Gas Semirigid Copper Tubing Sizing

This reprinted material is not the complete and official position of the NFPA on the referenced subject, which is represented only by the standard in its entirety.

Sizing of gas piping for proper fuel delivery, both flow and pressure, can become quite complex. A simplified method is to convert all fittings, valves, etc. to equivalent lengths of pipe in the diameter(s) being considered. The total equivalent length can then be related to flow capacity. Equivalent lengths of pipe fittings and valves can be found in the table below.

TABLE 28. NFPA EQUIVALENT LENGTHS OF PIPE FITTINGS AND VALVES IN FEET (METERS)

Type of Fitting	Nominal Inch (Millimeters) Pipe Size								
	1/2 (15)	3/4 (20)	1 (25)	1-1/4 (32)	1-1/2 (40)	2 (50)	2-1/2 (65)	3 (80)	4 (100)
90° Std. Elbow or Tee Reduced ½.	1.6 (0.5)	2.0 (0.6)	2.6 (0.8)	3.3 (1.0)	4.0 (1.2)	5.0 (1.5)	6.0 (1.8)	7.5 (2.3)	10.0 (3.1)
90° Long Radius Elbow or Straight Run Tee	1.0 (0.3)	1.4 (0.4)	1.7 (0.5)	2.3 (0.7)	2.6 (0.8)	3.3 (1.0)	4.1 (1.3)	5.0 (1.5)	6.7 (2.0)
45° Elbow	0.8 (0.2)	0.9 (0.3)	1.3 (0.4)	1.7 (0.5)	2.1 (0.6)	2.6 (0.8)	3.2 (1.0)	4.0 (1.2)	5.2 (1.6)
180° Std. Bend	2.5 (0.8)	3.2 (1.0)	4.1 (1.2)	5.6 (1.7)	6.3 (1.9)	8.2 (2.5)	10.0 (3.1)	12.0 (3.7)	17.0 (5.2)
TEE, Side Inlet or Outlet	3.0 (0.9)	4.0 (1.2)	5.0 (1.5)	7.0 (2.1)	8.0 (2.4)	10.0 (3.0)	12.0 (3.7)	15.0 (4.6)	21.0 (6.4)
Foot Valve and Strainer	3.7 (1.1)	4.9 (1.5)	7.5 (2.3)	8.9 (2.7)	11.0 (3.4)	15.0 (4.6)	18.0 (5.5)	22.0 (6.7)	29.0 (8.8)
Swing Check Valve, Fully Open	6.0 (1.8)	8.0 (2.4)	10.0 (3.0)	14.0 (4.3)	16.0 (4.9)	20.0 (6.1)	25.0 (7.6)	30.0 (9.1)	40.0 (12.2)

Globe Valve, Fully Open	18.0 (5.5)	22.0 (6.7)	29.0 (8.8)	38.0 (11.6)	43.0 (13.1)	55.0 (16.8)	69.0 (21.0)	84.0 (25.6)	120.0 (36.6)
Angle Valve, Fully Open	7.0 (2.1)	9.0 (2.7)	12.0 (3.7)	15.0 (4.6)	18.0 (5.5)	24.0 (7.3)	29.0 (8.8)	35.0 (10.7)	47.0 (14.3)
Gate Valve, Fully Open	0.7 (0.2)	0.9 (0.3)	1.0 (0.3)	1.5 (0.5)	1.8 (0.5)	2.3 (0.7)	2.8 (0.9)	3.2 (1.0)	4.5 (1.4)

The remaining tables in this section show maximum gas capacity for equivalent lengths of various pipe sizes.

Here are some basic but very important steps that all installers must follow to make sure that fuel lines are sized correctly:

1. Verify adequate fuel flow, quality, and pressure available from the natural gas utility connection.
2. Obtain the maximum fuel consumption requirements at full load for the specific generator set from the Model Specifications section and for all gas appliances attached to the pipe system.
3. Make a list of all the fittings and valves in the proposed system used in this generator set installation.
4. Determine the equivalent length of all fuel line fittings (elbows, tees, and valves). See the NFPA Equivalent Lengths of Pipe Fittings and Valves in Feet (Meters) table above in this to determine the equivalent lengths for all fuel line fittings.
5. Add the equivalent length of the fuel line fittings to the lengths of straight pipe to determine the total equivalent length of the system.
6. Choose the applicable natural gas table in this appendix based on fuel line material.
7. Determine the fuel line size at full load:
 - a. Locate the equivalent length of pipe (or next larger equivalent length) in the left hand column.
 - b. Move across the row to where the maximum flow capacity number is as large or larger than the maximum fuel consumption.
 - c. Move to the top of that column to where the minimum nominal pipe size or tubing size required **for the system as designed** is shown.

TABLE 30. NATURAL GAS SCHEDULE 40 METALLIC PIPE SIZING IN INCHES

Gas:	Natural
Inlet Pressure:	Less than 2 psi
Pressure Drop:	0.5 in. water column

Specific Gravity:	0.6
--------------------------	------------

Nominal:	Pipe Size													
	1/2	3/4	1	1 1/4	1 1/2	2	2 1/2	3	4	5	6	8	10	12
Actual ID:	0.622	0.824	1.049	1.38	1.61	2.067	2.469	3.068	4.026	5.047	6.065	7.981	10.02	11.938
Length (ft)	Capacity in Cubic Feet of Gas per Hour													
10	172	360	678	1390	2090	4020	6400	11300	23100	41800	67600	139000	252000	399000
20	118	247	466	957	1430	2760	4400	7780	15900	28700	46500	95500	173000	275000
30	95	199	374	768	1150	2220	3530	6250	12700	23000	37300	76700	139000	220000
40	81	170	320	657	985	1900	3020	5350	10900	19700	31900	65600	119000	189000
50	72	151	284	583	873	1680	2680	4740	9660	17500	28300	58200	106000	167000
60	65	137	257	528	791	1520	2430	4290	8760	15800	25600	52700	95700	152000
70	60	126	237	486	728	1400	2230	3950	8050	14600	23600	48500	88100	139000
80	56	117	220	452	677	1300	2080	3670	7490	13600	22000	45100	81900	130000
90	52	110	207	424	635	1220	1950	3450	7030	12700	20600	42300	76900	122000
100	50	104	195	400	600	1160	1840	3260	6640	12000	19500	40000	72600	115000
125	44	92	173	355	532	1020	1630	2890	5890	10600	17200	35400	64300	102000
150	40	83	157	322	482	928	1480	2610	5330	9650	15600	32100	58300	92300
175	37	77	144	296	443	854	1360	2410	4910	8880	14400	29500	53600	84900
200	34	71	134	275	412	794	1270	2240	4560	8260	13400	27500	49900	79000
250	30	63	119	244	366	704	1120	1980	4050	7320	11900	24300	44200	70000
300	27	57	108	221	331	638	1020	1800	3670	6630	10700	22100	40100	63400
350	25	53	99	203	305	587	935	1650	3370	6100	9880	20300	36900	58400
400	23	49	92	189	283	546	870	1540	3140	5680	9190	18900	34300	54300
450	22	46	86	177	266	512	816	1440	2940	5330	8620	17700	32200	50900
500	21	43	82	168	251	484	771	1360	2780	5030	8150	16700	30400	48100
550	20	41	78	159	239	459	732	1290	2640	4780	7740	15900	28900	45700
600	19	39	74	152	228	438	699	1240	2520	4560	7380	15200	27500	43600
650	18	38	71	145	218	420	669	1180	2410	4360	7070	14500	26400	41800
700	17	36	68	140	209	403	643	1140	2320	4190	6790	14000	25300	40100
750	17	35	66	135	202	389	619	1090	2230	4040	6540	13400	24400	38600
800	16	34	63	130	195	375	598	1060	2160	3900	6320	13000	23600	37300

850	16	33	61	126	189	363	579	1020	2090	3780	6110	12600	22800	36100
900	15	32	59	122	183	352	561	992	2020	3660	5930	12200	22100	35000
950	15	31	58	118	178	342	545	963	1960	3550	5760	11800	21500	34000
1000	14	30	56	115	173	333	530	937	1910	3460	5600	11500	20900	33100
1100	14	28	53	109	164	316	503	890	1810	3280	5320	10900	19800	31400
1200	13	27	51	104	156	301	480	849	1730	3130	5070	10400	18900	30000
1300	12	26	49	100	150	289	460	813	1660	3000	4860	9980	18100	28700
1400	12	25	47	96	144	277	442	781	1590	2880	4670	9590	17400	27600
1500	11	24	45	93	139	267	426	752	1530	2780	4500	9240	16800	26600
1600	11	23	44	89	134	258	411	727	1480	2680	4340	8920	16200	25600
1700	11	22	42	86	130	250	398	703	1430	2590	4200	8630	15700	24800
1800	10	22	41	84	126	242	386	682	1390	2520	4070	8370	15200	24100
1900	10	21	40	81	122	235	375	662	1350	2440	3960	8130	14800	23400
2000	NA	20	39	79	119	229	364	644	1310	2380	3850	7910	14400	22700

TABLE 33. NATURAL GAS SEMIRIGID COPPER TUBING SIZING

Gas:	Natural
Inlet Pressure:	Less than 2 psi
Pressure Drop:	0.5 in. water column
Specific Gravity:	0.6

	Tube Size (in.)								
	1/4	3/8	1/2	5/8	3/4	1	1 1/4	1 1/2	2
Nominal K & L:	3/8	1/2	5/8	3/4	7/8	1 1/8	1 3/8	—	—
Nominal ACR:	3/8	1/2	5/8	3/4	7/8	1 1/8	1 3/8	—	—
Outside:	0.375	0.5	0.625	0.75	0.875	1.125	1.375	1.625	2.125
Inside:*	0.305	0.402	0.527	0.652	0.745	0.995	1.245	1.481	1.959
Length (ft.)	Capacity in Cubic Feet of Gas per Hour								
10	27	55	111	195	276	590	1,060	1,680	3,490
20	18	38	77	134	190	406	730	1,150	2,400
30	15	30	61	107	152	326	586	925	1,930

40	13	26	53	92	131	279	502	791	1,650
50	11	23	47	82	116	247	445	701	1,460
60	10	21	42	74	105	224	403	635	1,320
70	NA	19	39	68	96	206	371	585	1,220
80	NA	18	36	63	90	192	345	544	1,130
90	NA	17	34	59	84	180	324	510	1,060
100	NA	16	32	56	79	170	306	482	1,000
125	NA	14	28	50	70	151	271	427	890
150	NA	13	26	45	64	136	245	387	806
175	NA	12	24	41	59	125	226	356	742
200	NA	11	22	39	55	117	210	331	690
250	NA	NA	20	34	48	103	186	294	612
300	NA	NA	18	31	44	94	169	266	554
350	NA	NA	16	28	40	86	155	245	510
400	NA	NA	15	26	38	80	144	228	474
450	NA	NA	14	25	35	75	135	214	445
500	NA	NA	13	23	33	71	128	202	420
550	NA	NA	13	22	32	68	122	192	399
600	NA	NA	12	21	30	64	116	183	381
650	NA	NA	12	20	29	62	111	175	365
700	NA	NA	11	20	28	59	107	168	350
750	NA	NA	11	19	27	57	103	162	338
800	NA	NA	10	18	26	55	99	156	326
850	NA	NA	10	18	25	53	96	151	315
900	NA	NA	NA	17	24	52	93	147	306
950	NA	NA	NA	17	24	50	90	143	297
1,000	NA	NA	NA	16	23	49	88	139	289
1,100	NA	NA	NA	15	22	46	84	132	274
1,200	NA	NA	NA	15	21	44	80	126	262
1,300	NA	NA	NA	14	20	42	76	120	251
1,400	NA	NA	NA	13	19	41	73	116	241
1,500	NA	NA	NA	13	18	39	71	111	232

1,600	NA	NA	NA	13	18	38	68	108	224
1,700	NA	NA	NA	12	17	37	66	104	217
1,800	NA	NA	NA	12	17	36	64	101	210
1,900	NA	NA	NA	11	16	35	62	98	204
2,000	NA	NA	NA	11	16	34	60	95	199

NA: A flow of less than 10 cfh.

Note: All table entries are rounded to 3 significant digits.

*Table capacities are based on Type K copper tubing inside diameter (shown), which has the smallest inside diameter of the copper tubing products.

Appendix B. Outline and System Drawings

Table of Contents

Figure 19. Generator Set Outline, 125-150 kW (Sheet 1 of 2) 77

Figure 20. Generator Set Outline, 125-150 kW (Sheet 2 of 2) 78

Figure 21. Generator Set Outline, Accessories (Sheet 1 of 2) 79

Figure 22. Generator Set Outline, Accessories (Sheet 2 of 2) 80

Figure 23. Foundation Outline (Sheet 1 of 1) 81

Figure 24. Enclosure Outline, Weather (Sheet 1 of 1) 82

Figure 25. Enclosure Outline, Sound Attention Level 1 and Level 2 (Sheet 1 of 2) 83

Figure 26. Enclosure Outline, Sound Attention Level 1 and Level 2 (Sheet 2 of 2) 84

The drawings included in this section are representative. For current complete information, refer to the drawing package that was shipped with the unit.

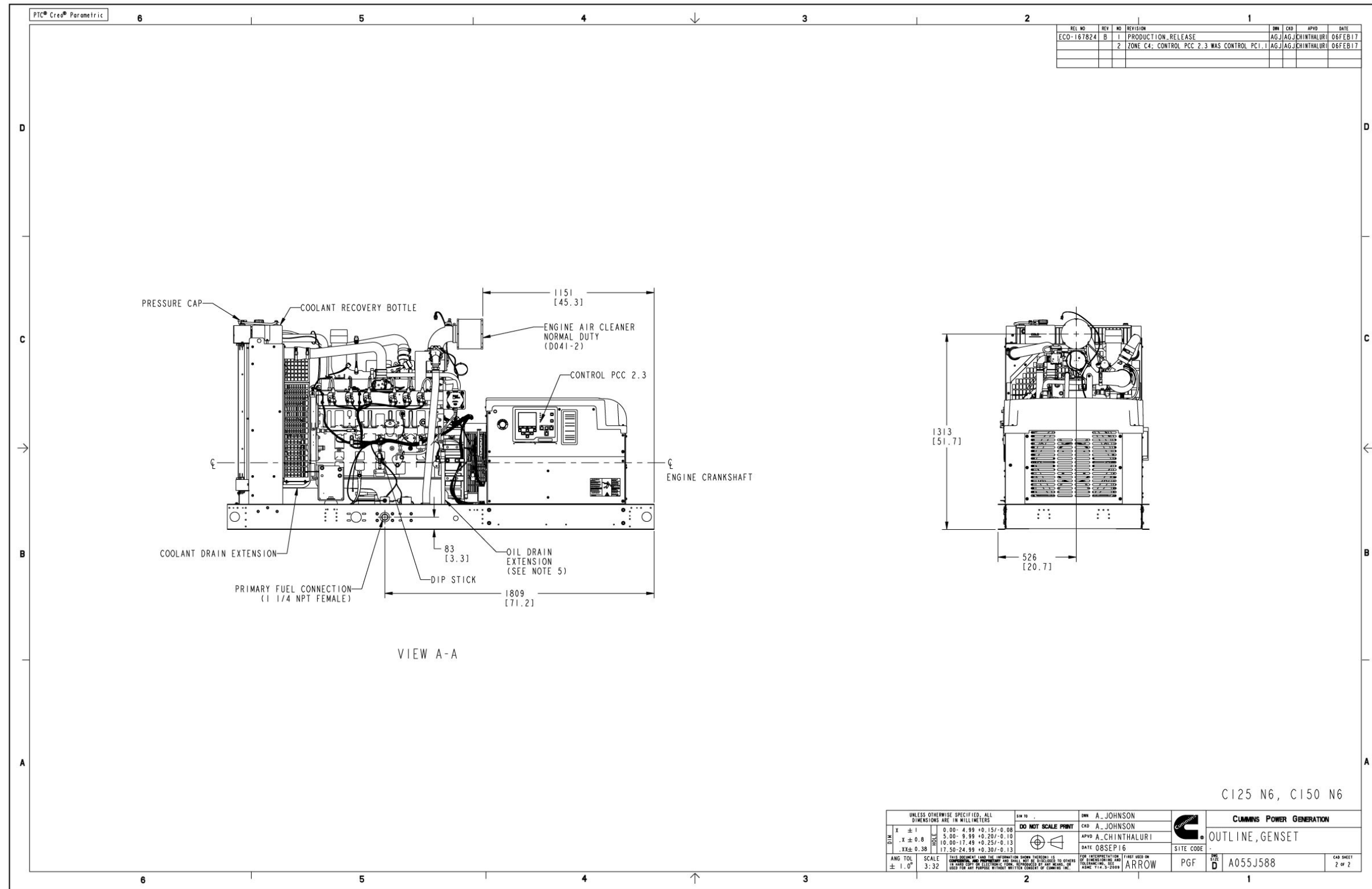

FIGURE 20. GENERATOR SET OUTLINE, 125-150 KW (SHEET 2 OF 2)

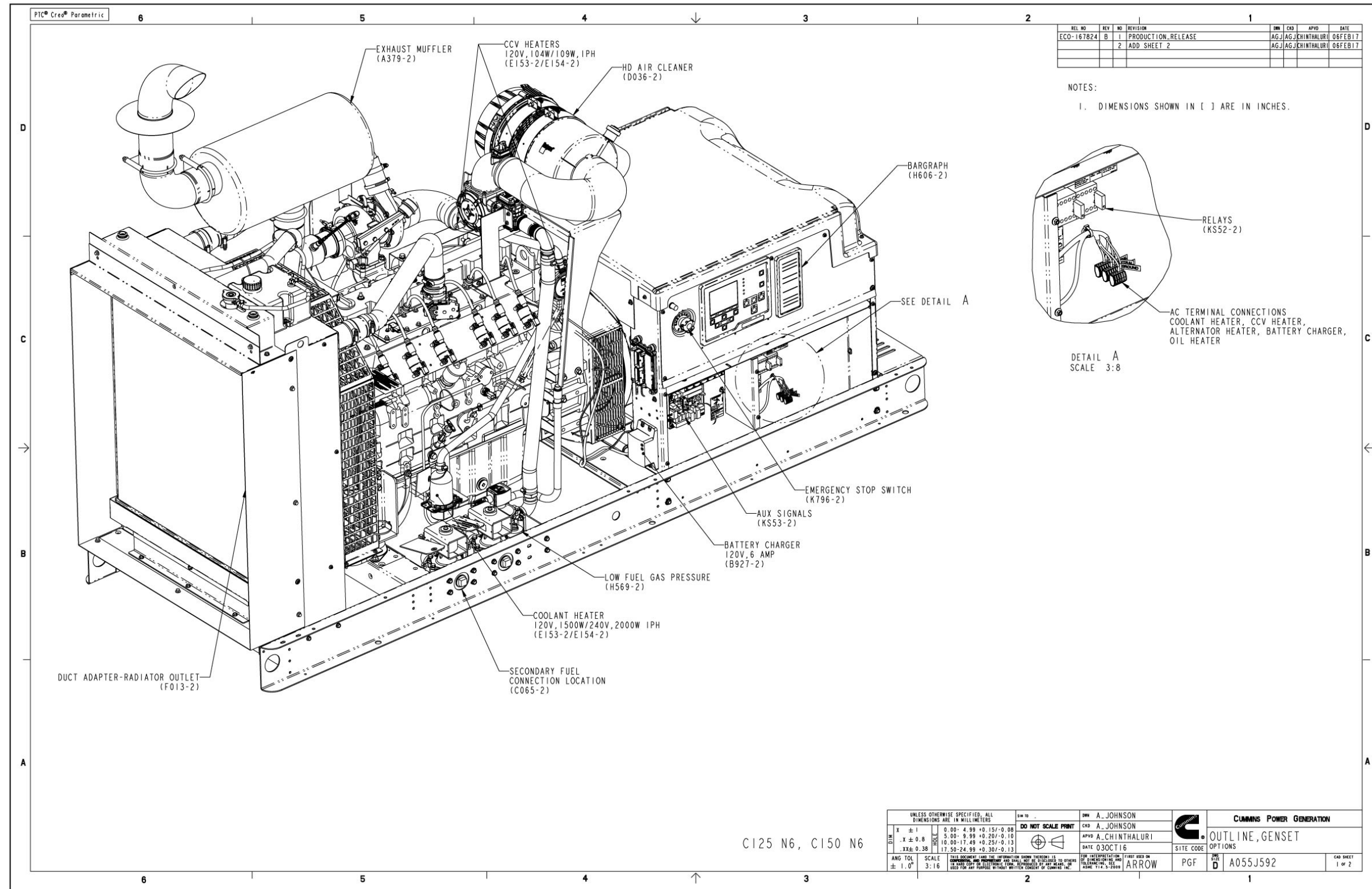

FIGURE 21. GENERATOR SET OUTLINE, ACCESSORIES (SHEET 1 OF 2)

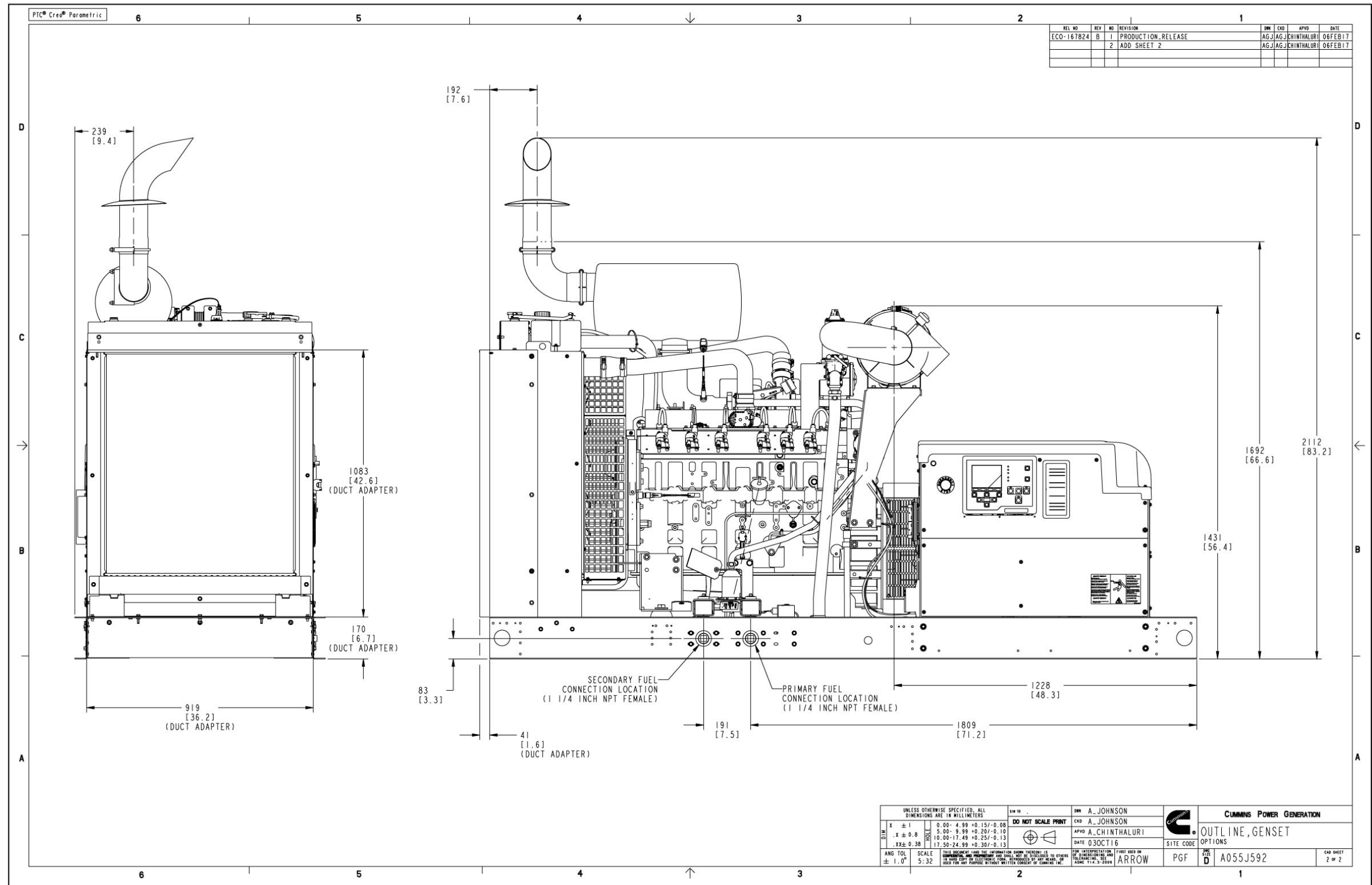

FIGURE 22. GENERATOR SET OUTLINE, ACCESSORIES (SHEET 2 OF 2)

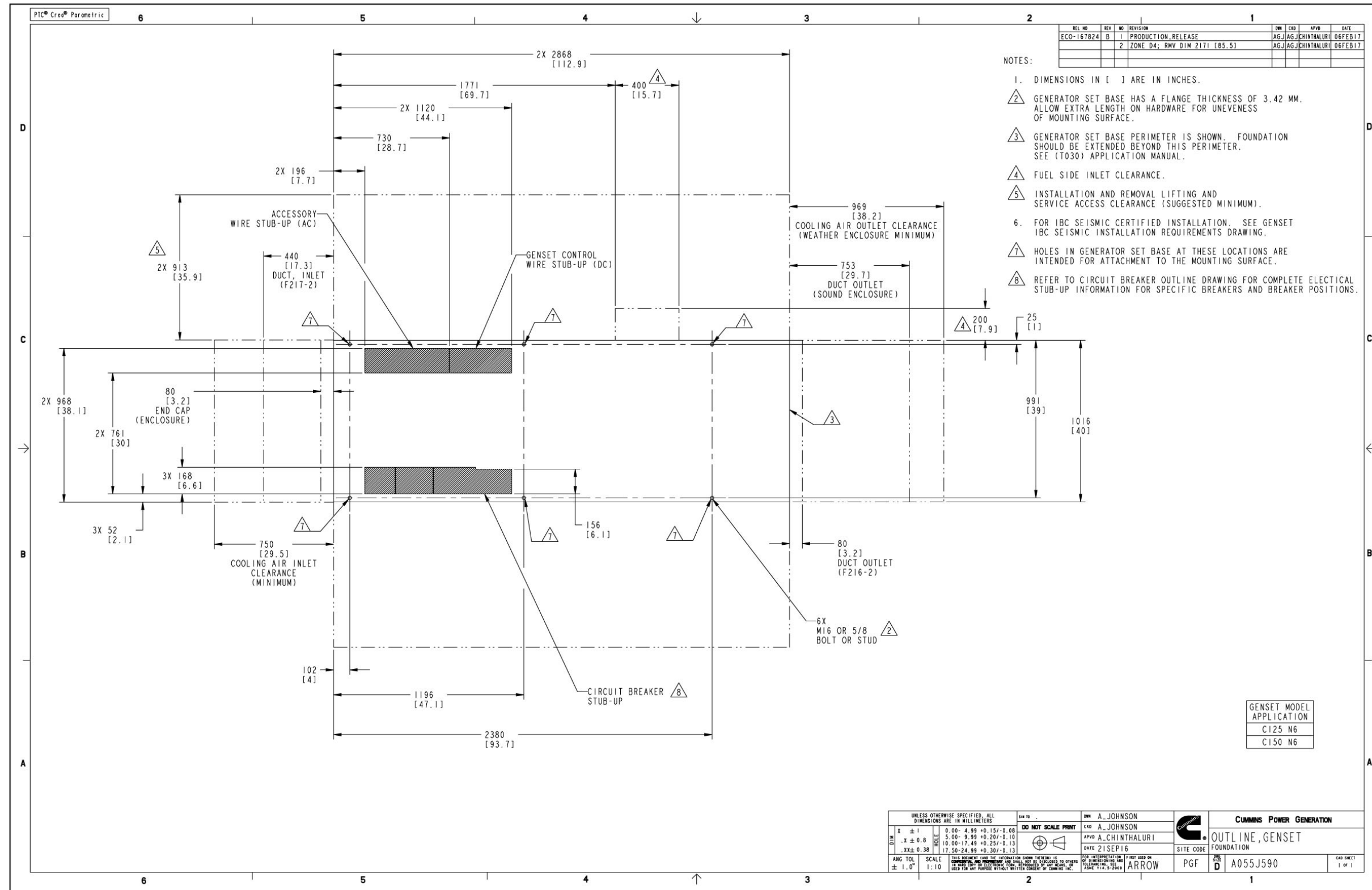

FIGURE 23. FOUNDATION OUTLINE (SHEET 1 OF 1)

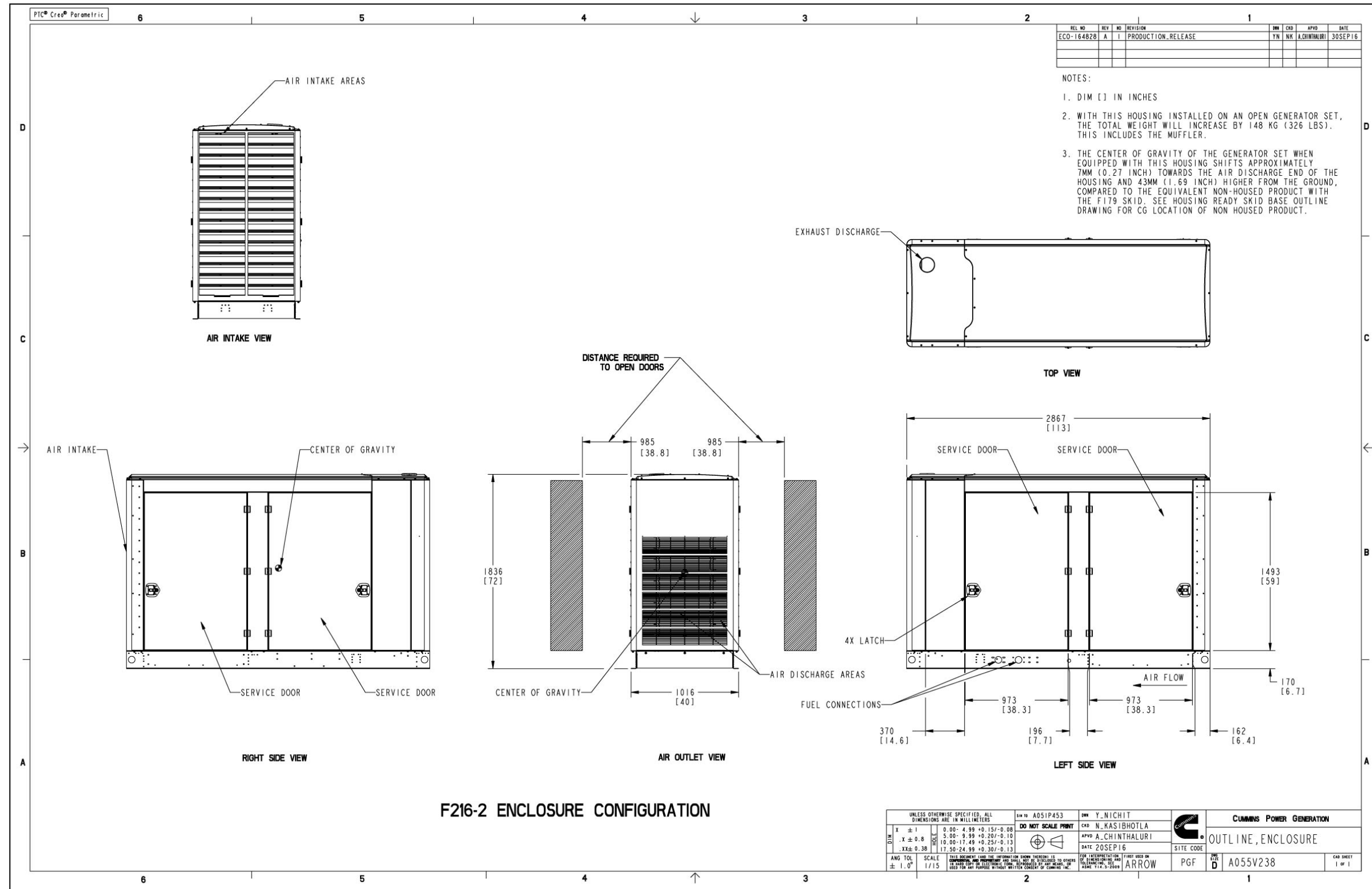

FIGURE 24. ENCLOSURE OUTLINE, WEATHER (SHEET 1 OF 1)

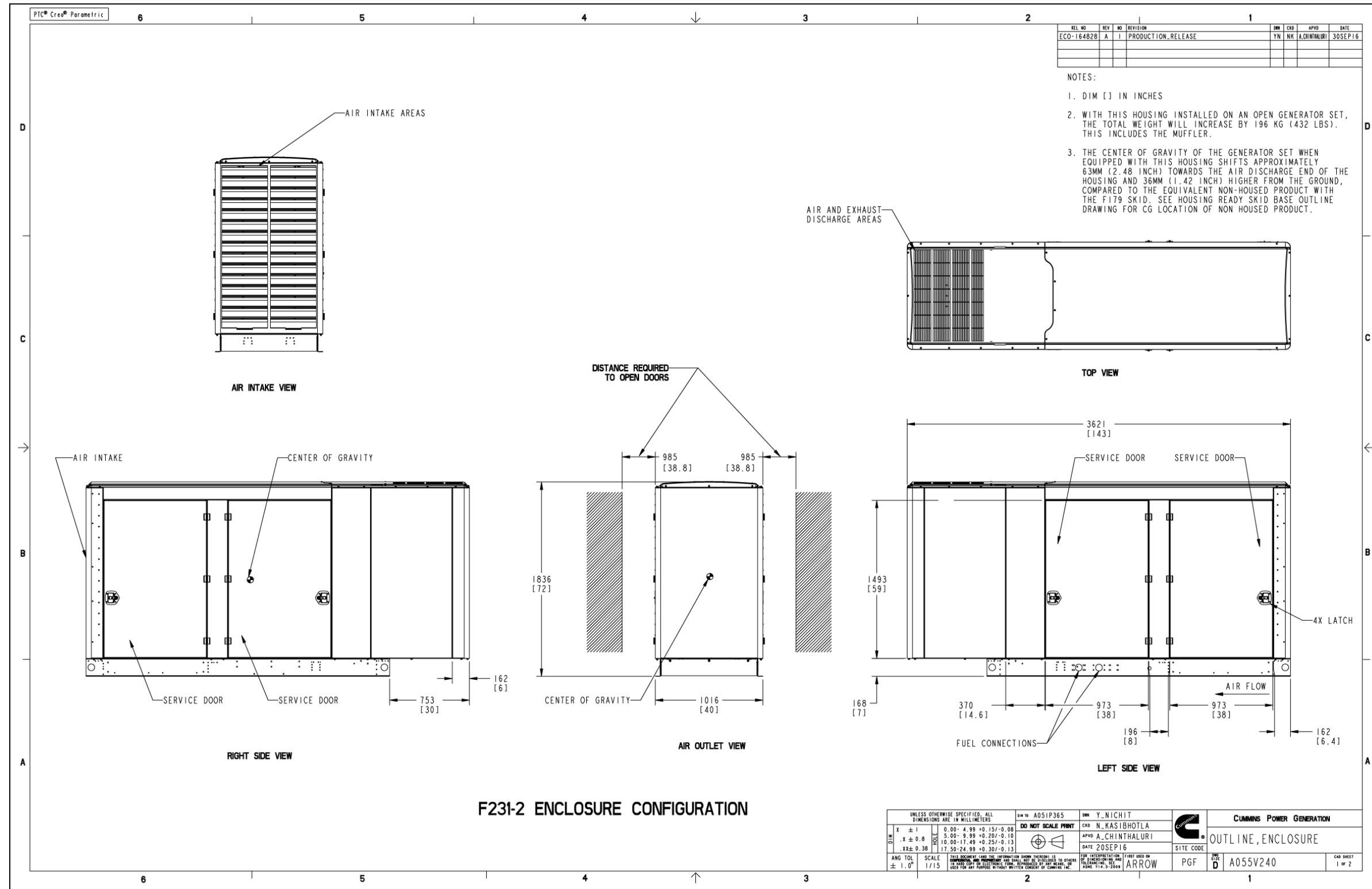

FIGURE 25. ENCLOSURE OUTLINE, SOUND ATTENTION LEVEL 1 AND LEVEL 2 (SHEET 1 OF 2)

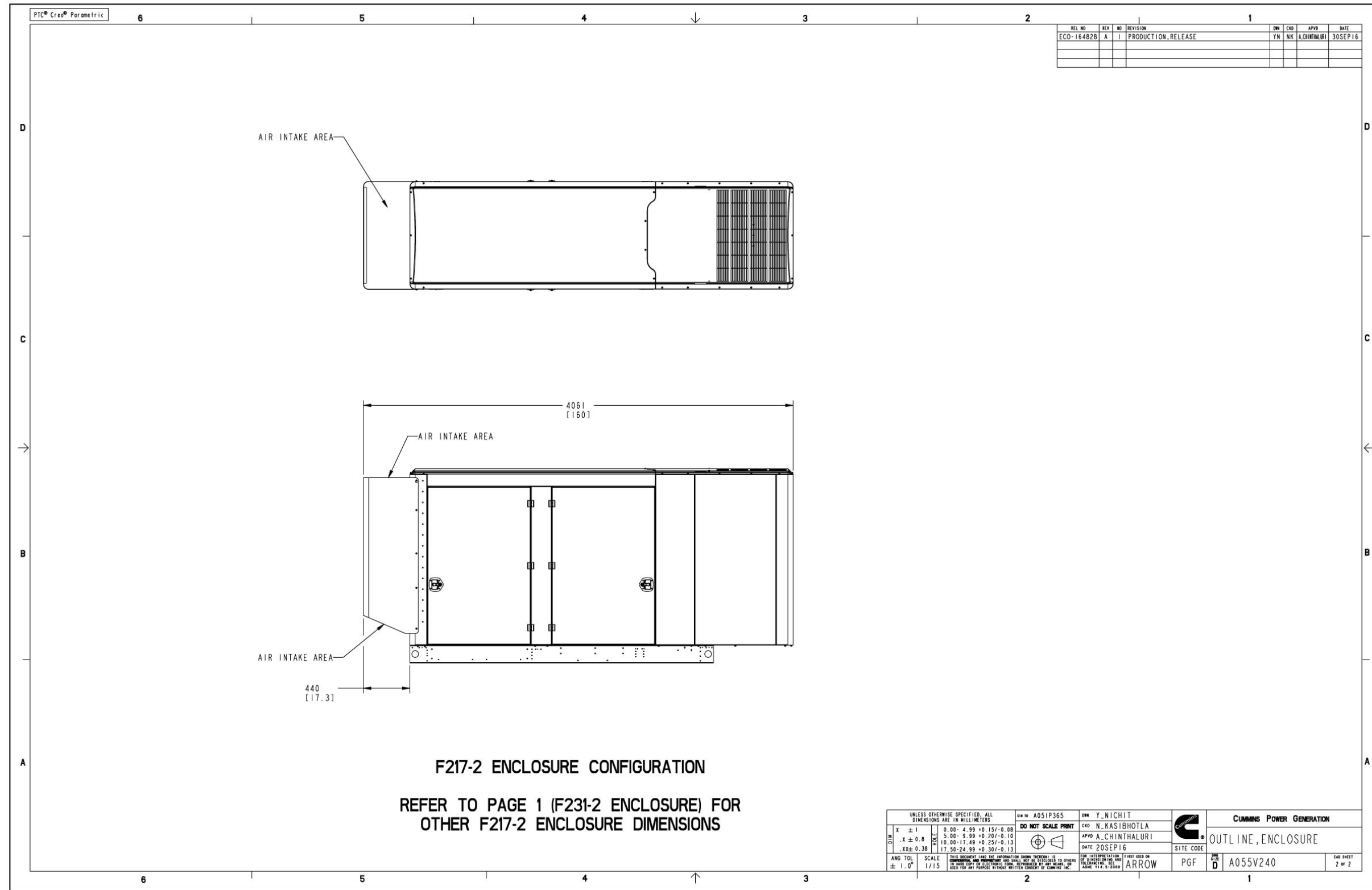

FIGURE 26. ENCLOSURE OUTLINE, SOUND ATTENTION LEVEL 1 AND LEVEL 2 (SHEET 2 OF 2)

Appendix C. Wiring Diagrams

Table of Contents

Figure 27. Wiring Diagram (Sheet 1 of 6) 87

Figure 28. Wiring Diagram (Sheet 2 of 6) 88

Figure 29. Wiring Diagram (Sheet 3 of 6) 89

Figure 30. Wiring Diagram (Sheet 4 of 6) 90

Figure 31. Wiring Diagram (Sheet 5 of 6) 91

Figure 32. Wiring Diagram (Sheet 5 of 6) 92

Figure 33. Harness, Generator Set Electrical (Sheet 1 of 3) 93

Figure 34. Harness, Generator Set Electrical (Sheet 2 of 3) 94

Figure 35. Harness, Generator Set Electrical (Sheet 3 of 3) 95

Figure 36. Control Box Harness Diagram (Sheet 1 of 4) 96

Figure 37. Control Box Harness Diagram (Sheet 2 of 4) 97

Figure 38. Control Box Harness Diagram (Sheet 3 of 4) 98

Figure 39. Control Box Harness Diagram (Sheet 4 of 4) 99

C.0 Wiring Diagrams

The drawings included in this section are representative. For current complete information, refer to the drawing package that was shipped with the unit.

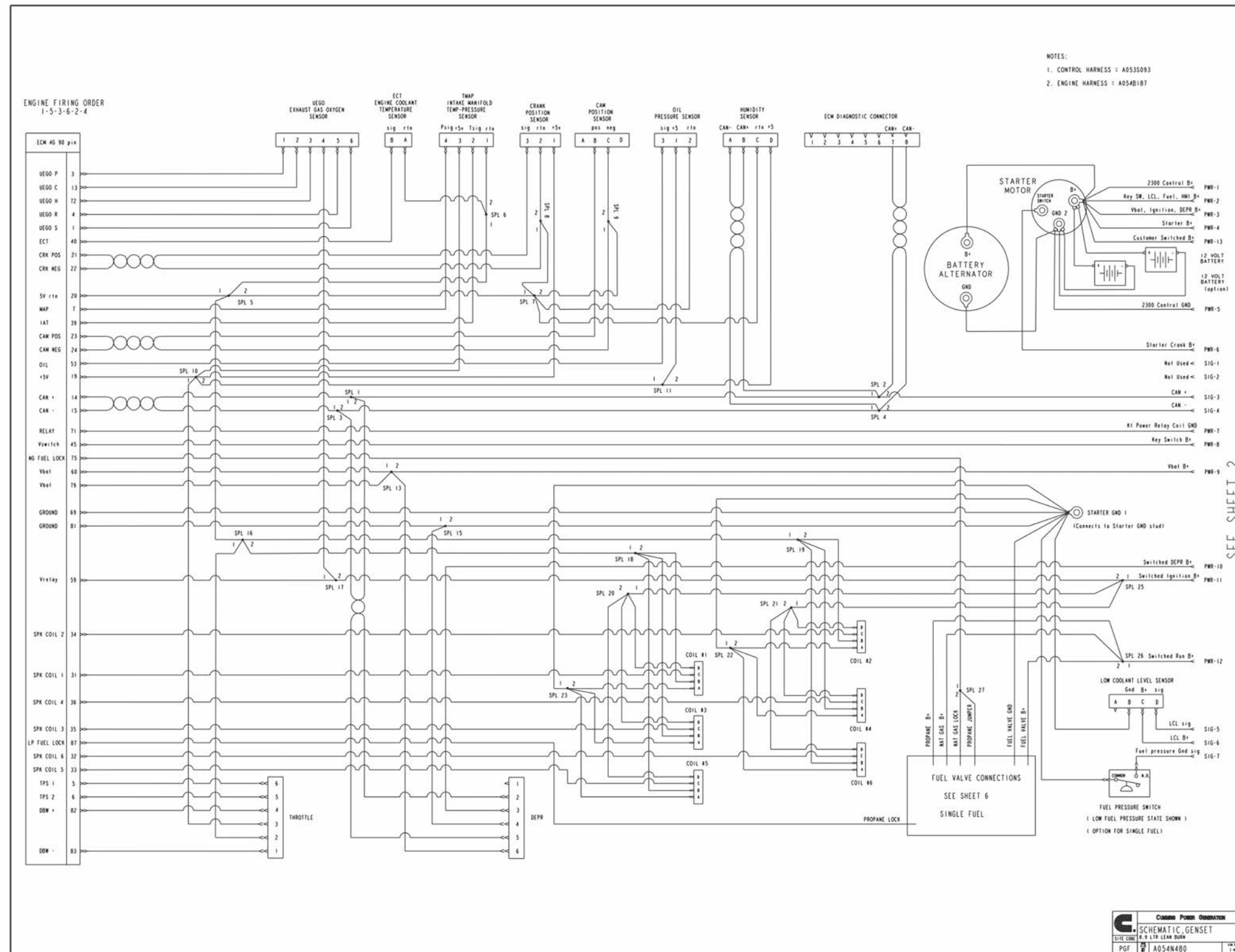

FIGURE 27. WIRING DIAGRAM (SHEET 1 OF 6)

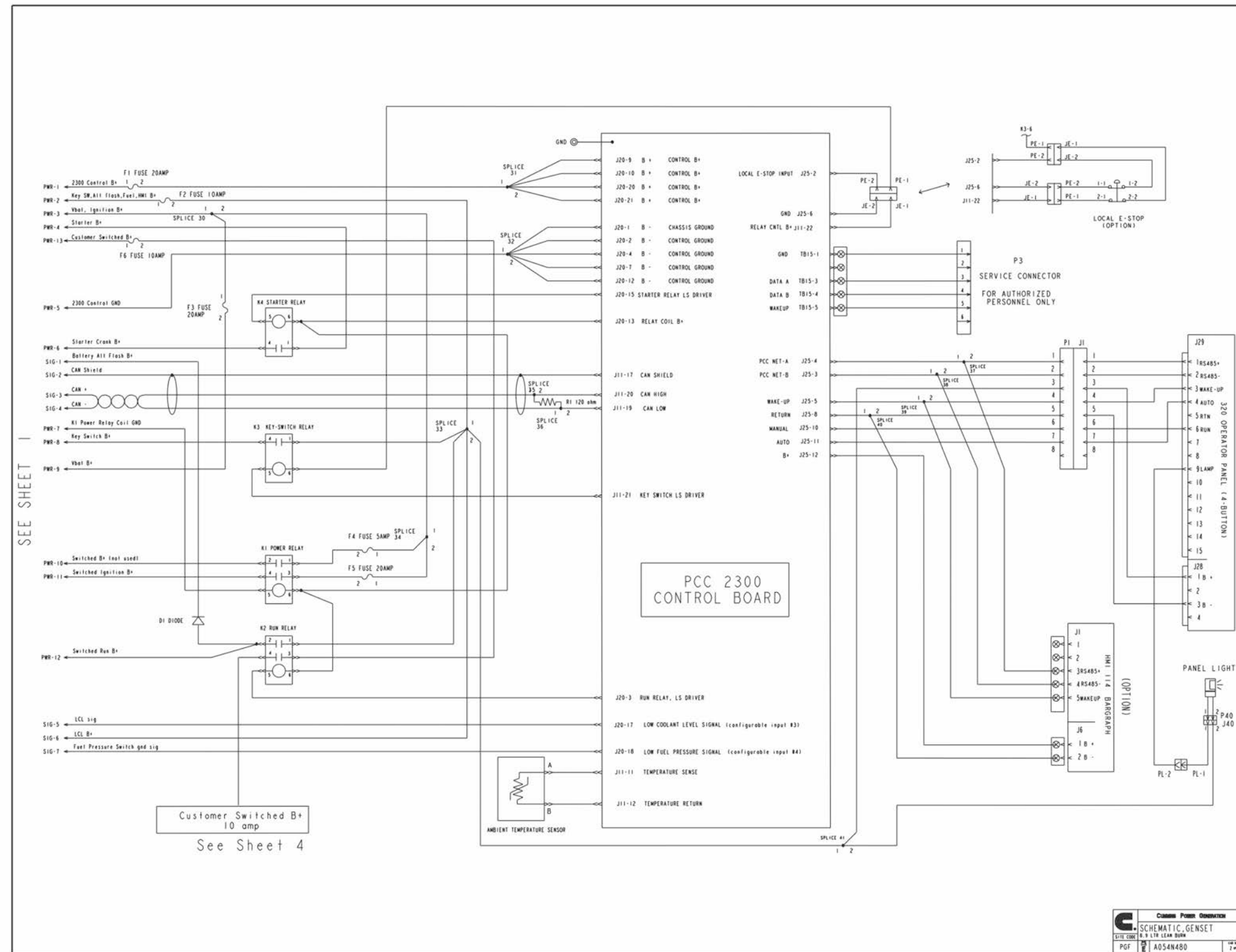

FIGURE 28. WIRING DIAGRAM (SHEET 2 OF 6)

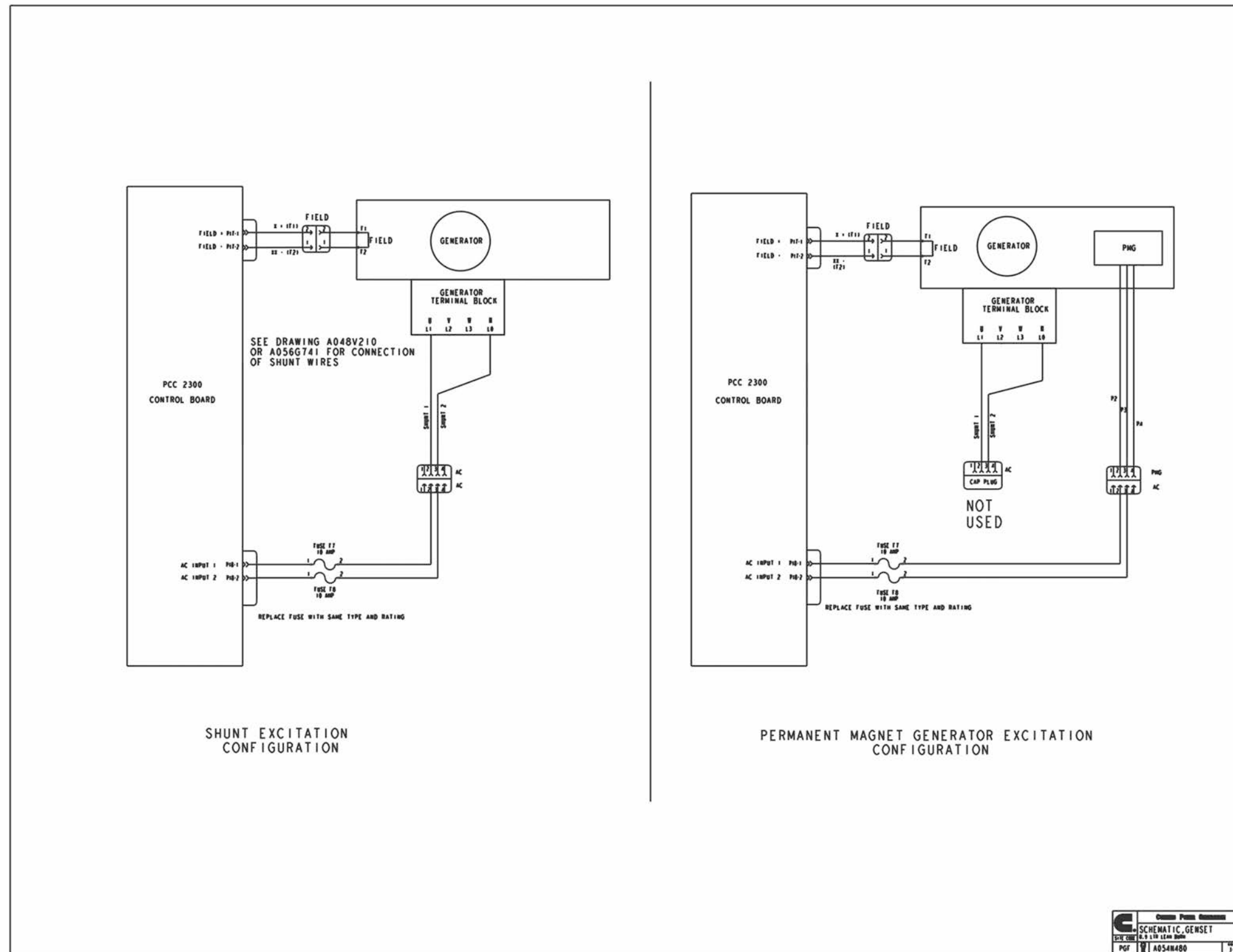

FIGURE 29. WIRING DIAGRAM (SHEET 3 OF 6)

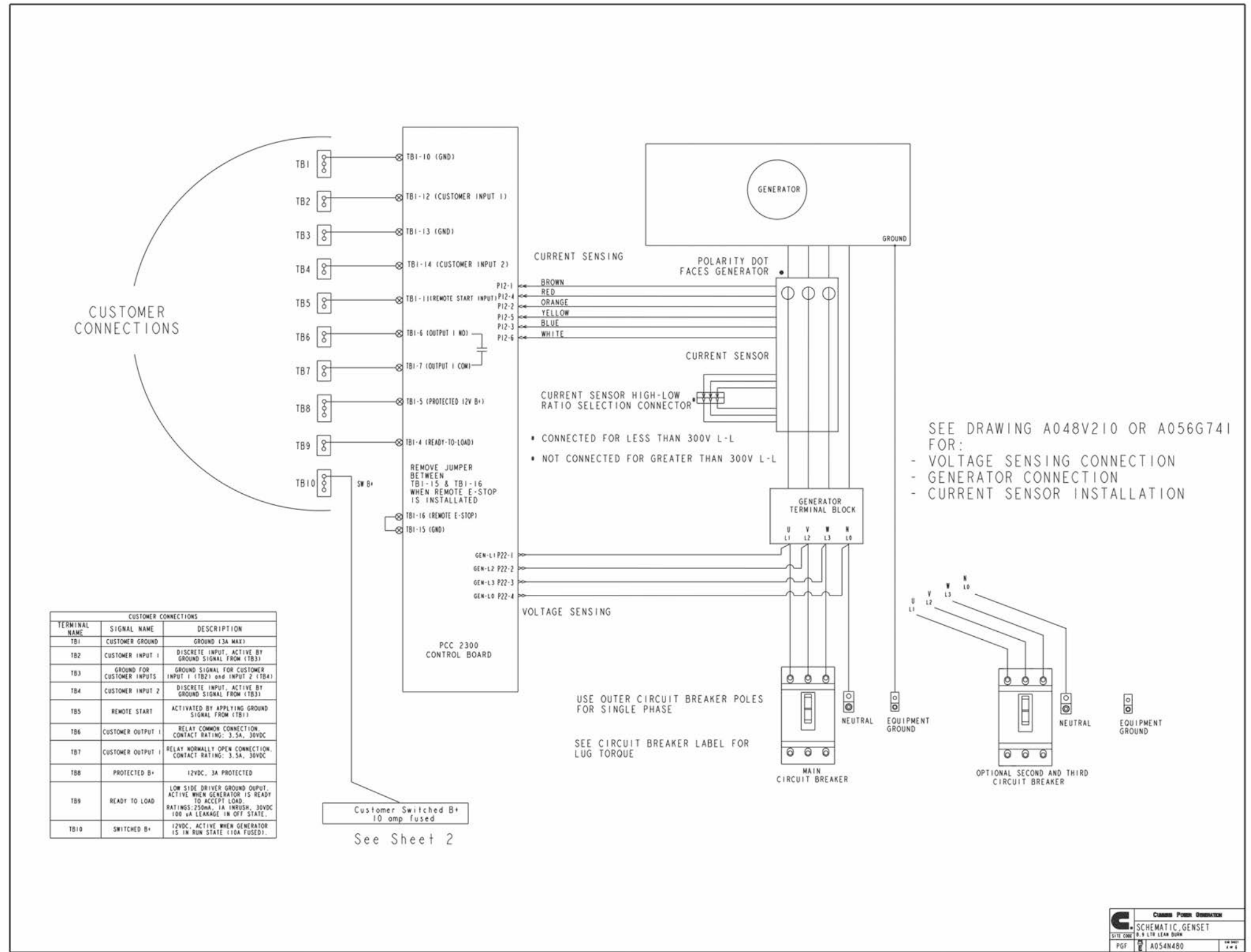

FIGURE 30. WIRING DIAGRAM (SHEET 4 OF 6)

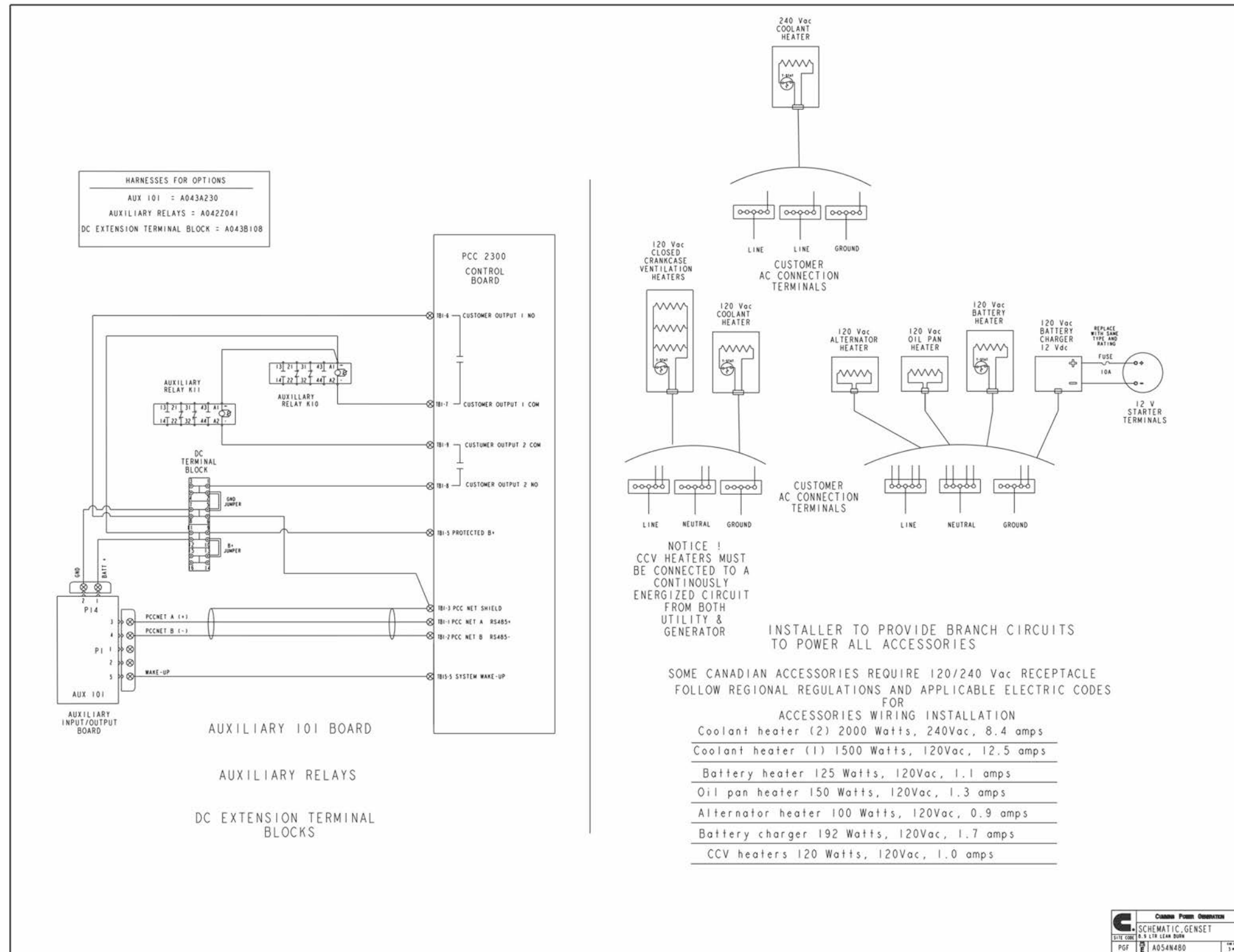

FIGURE 31. WIRING DIAGRAM (SHEET 5 OF 6)

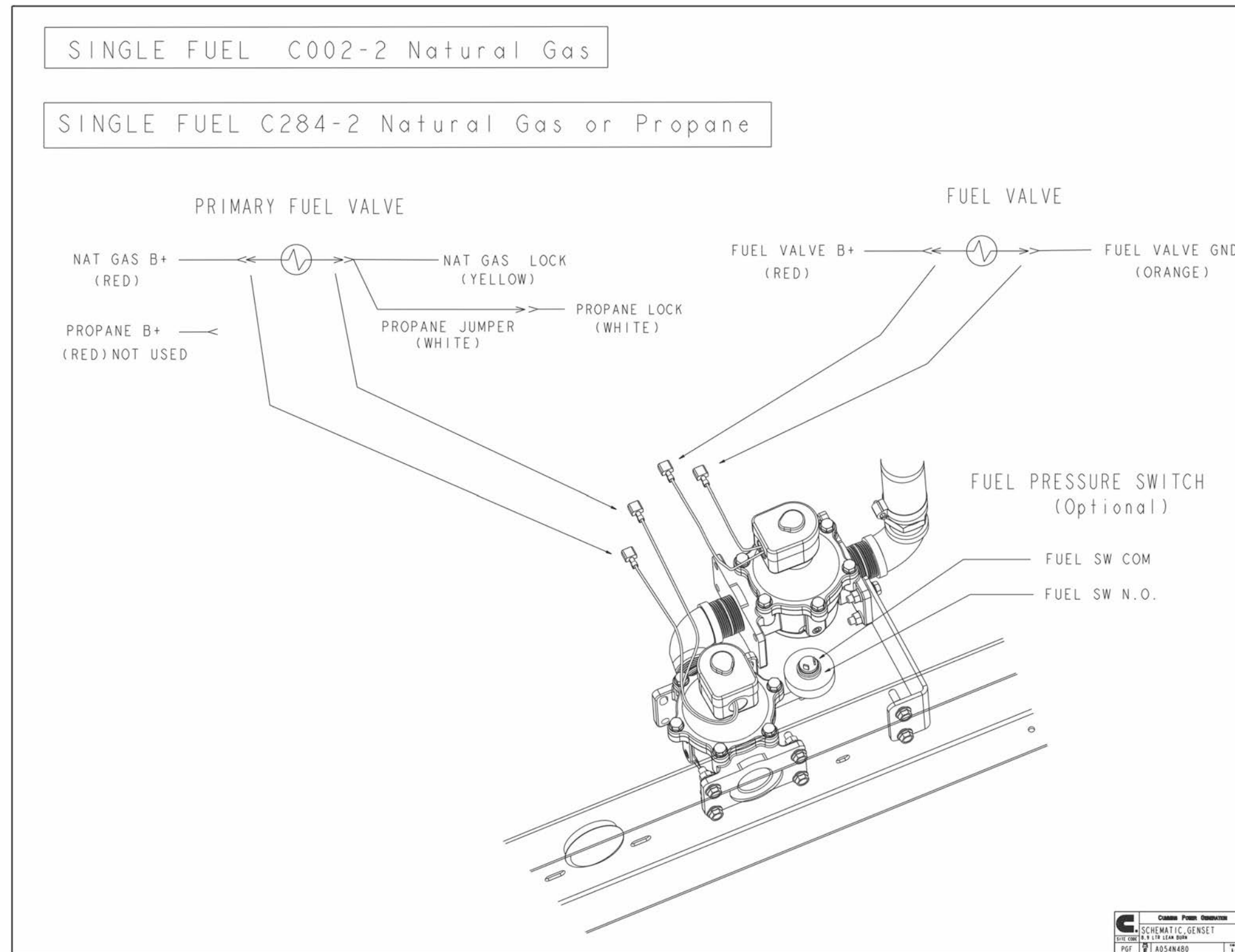
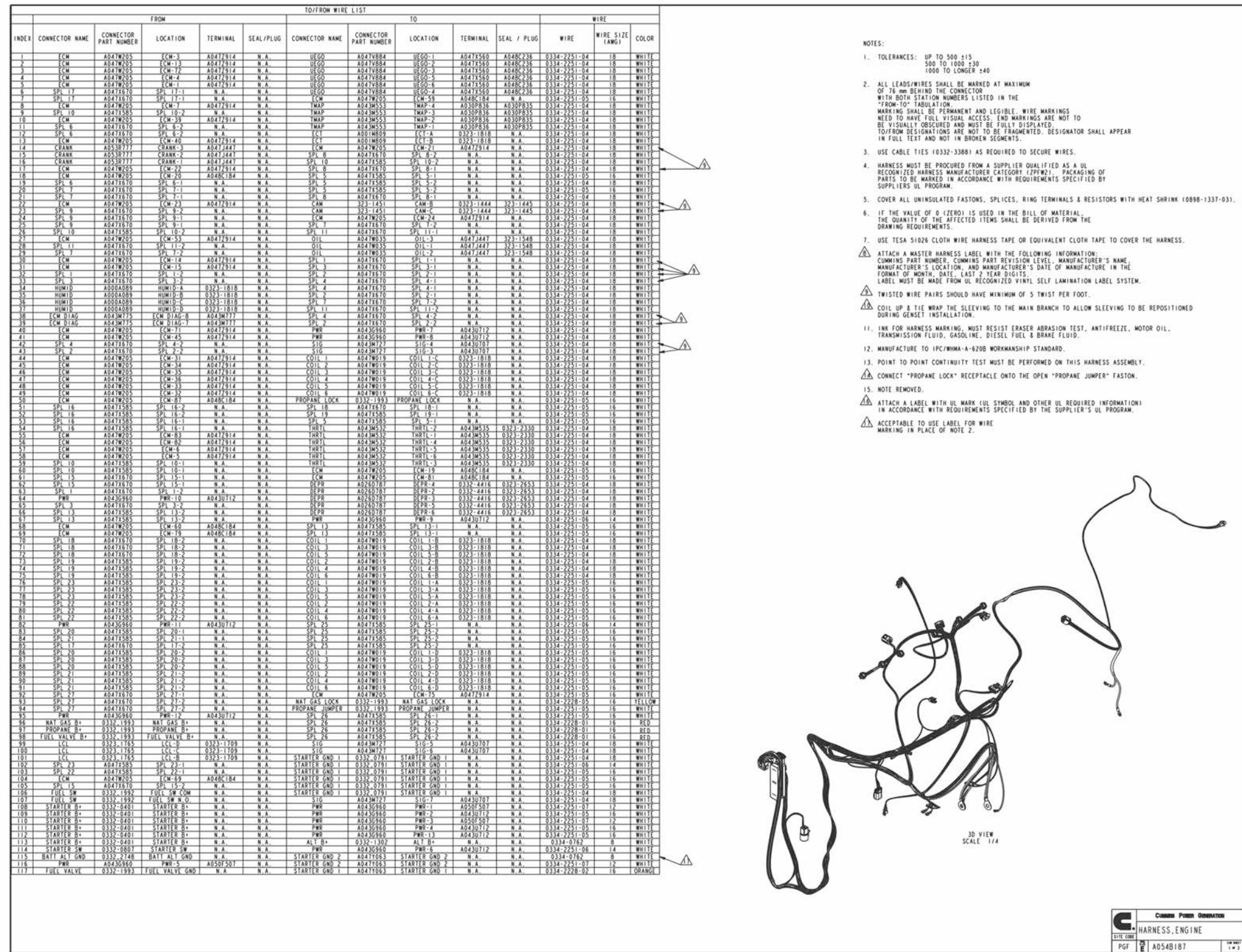

FIGURE 32. WIRING DIAGRAM (SHEET 5 OF 6)



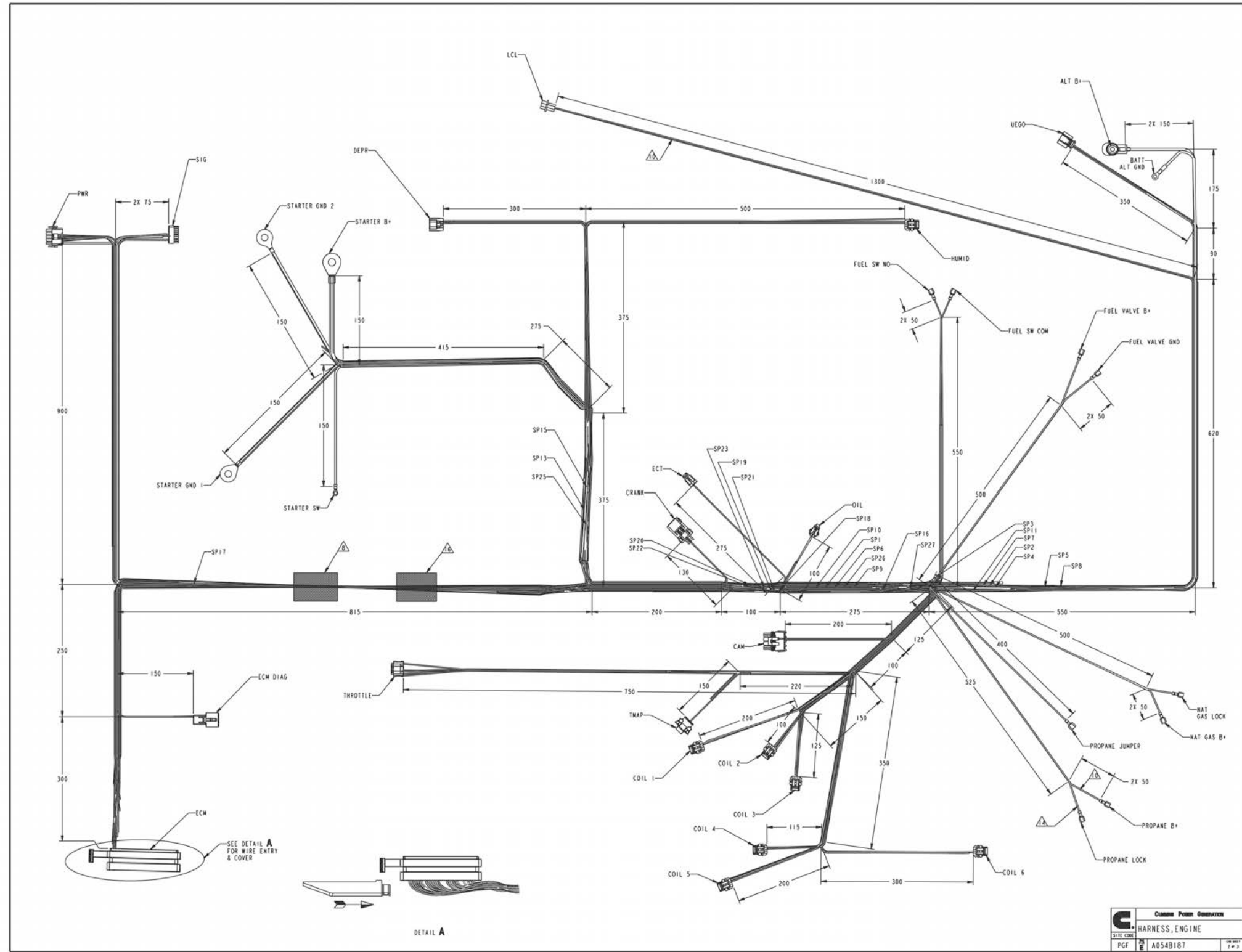

FIGURE 34. HARNESS, GENERATOR SET ELECTRICAL (SHEET 2 OF 3)

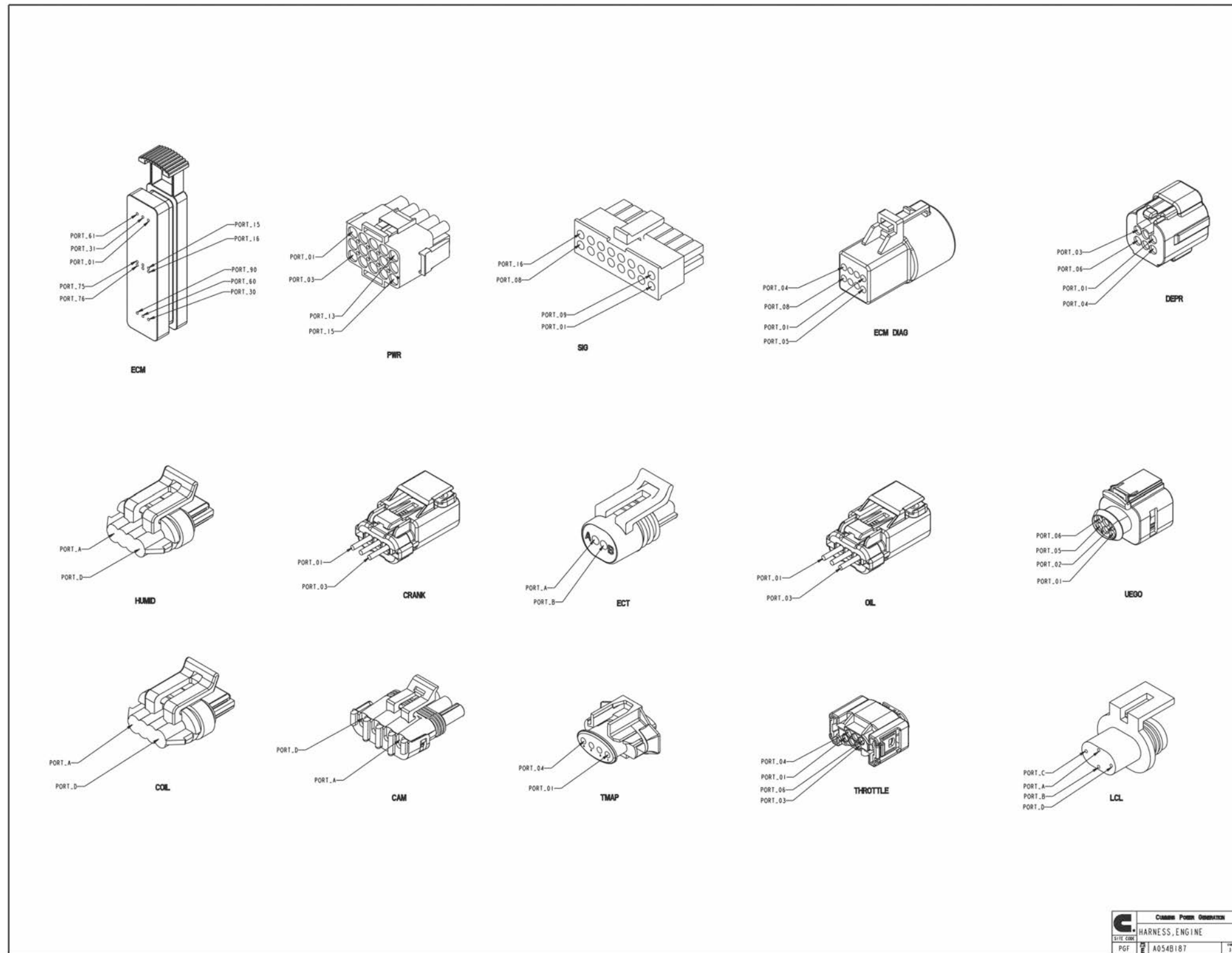

FIGURE 35. HARNESS, GENERATOR SET ELECTRICAL (SHEET 3 OF 3)

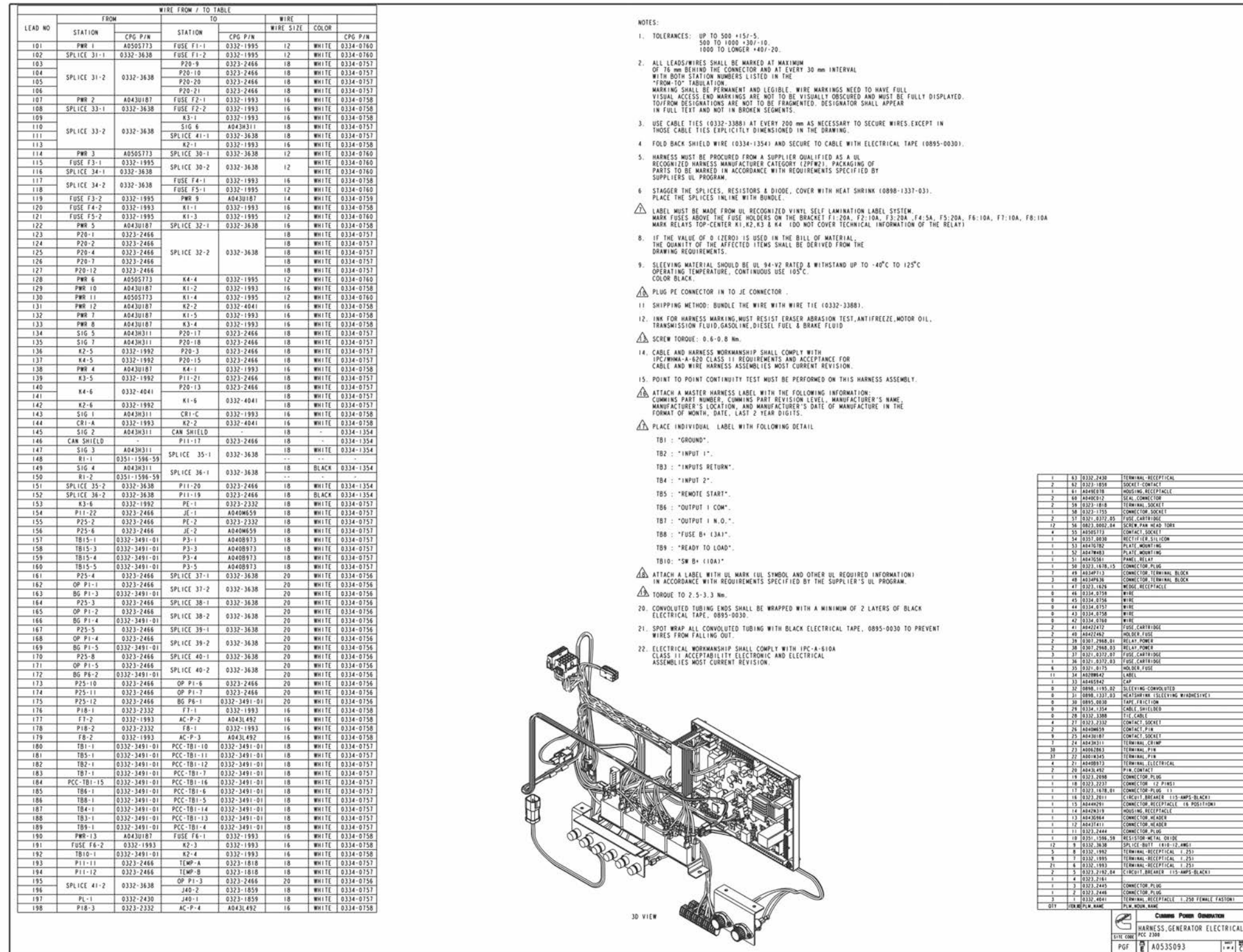

FIGURE 36. CONTROL BOX HARNESS DIAGRAM (SHEET 1 OF 4)

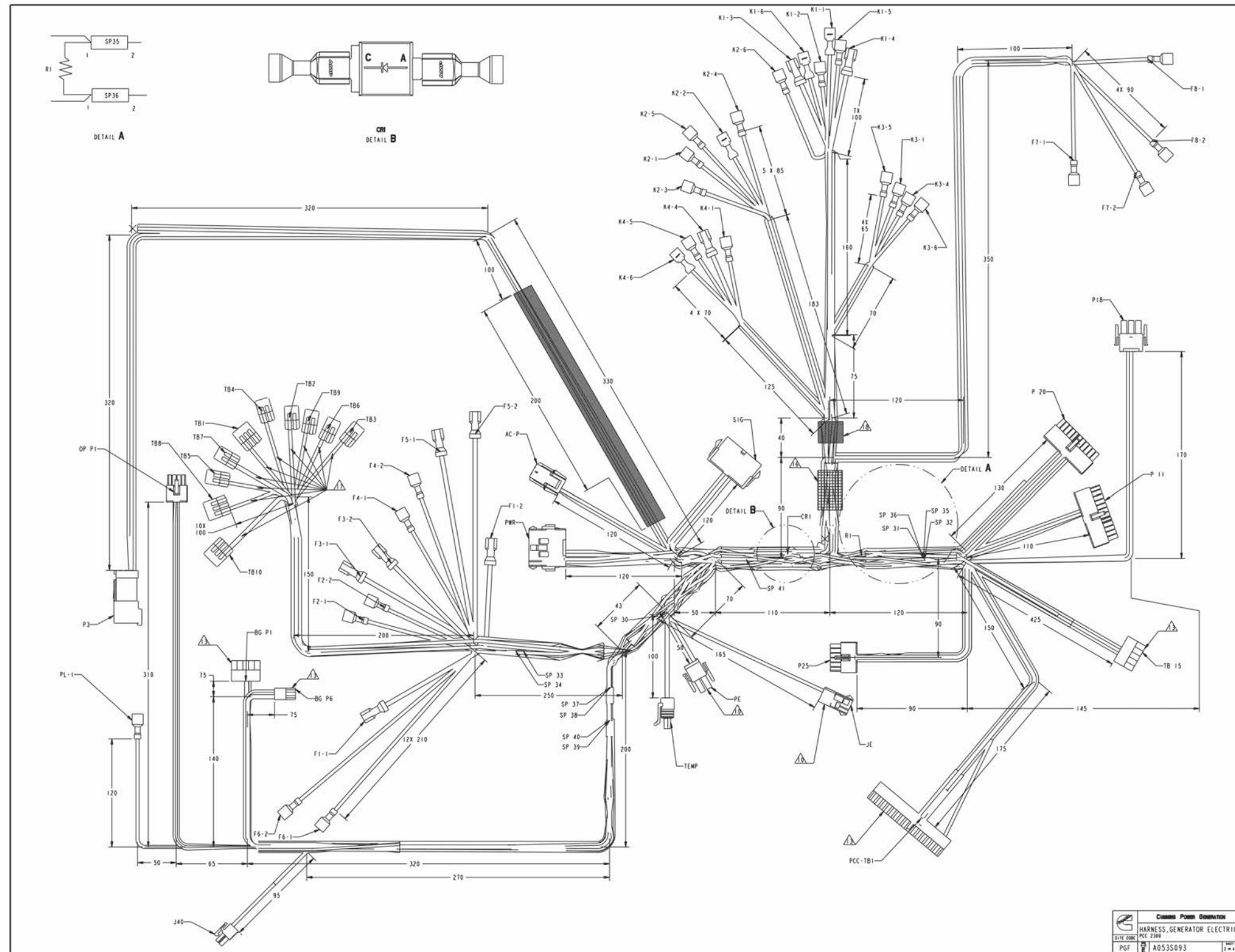

FIGURE 37. CONTROL BOX HARNESS DIAGRAM (SHEET 2 OF 4)

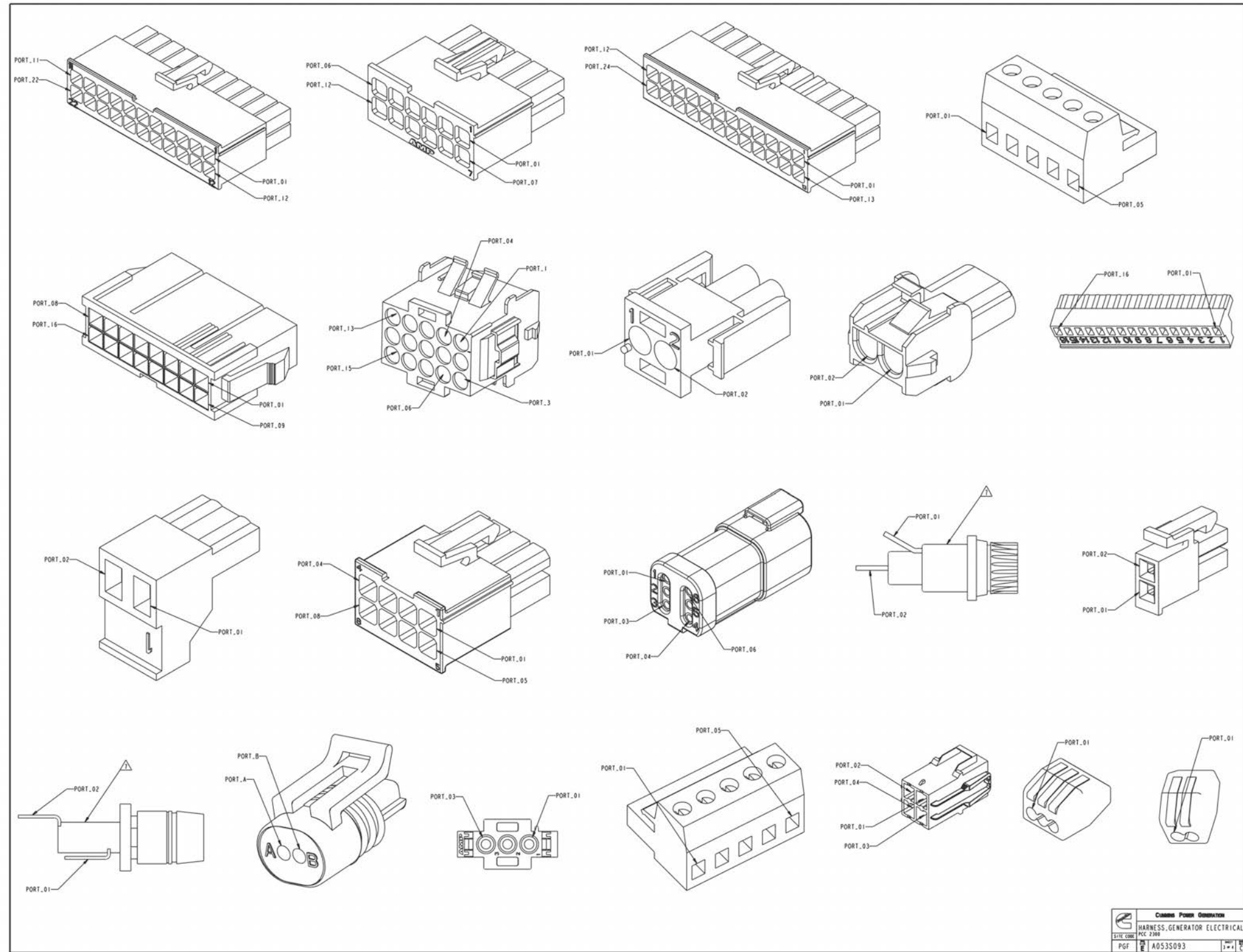

FIGURE 38. CONTROL BOX HARNESS DIAGRAM (SHEET 3 OF 4)

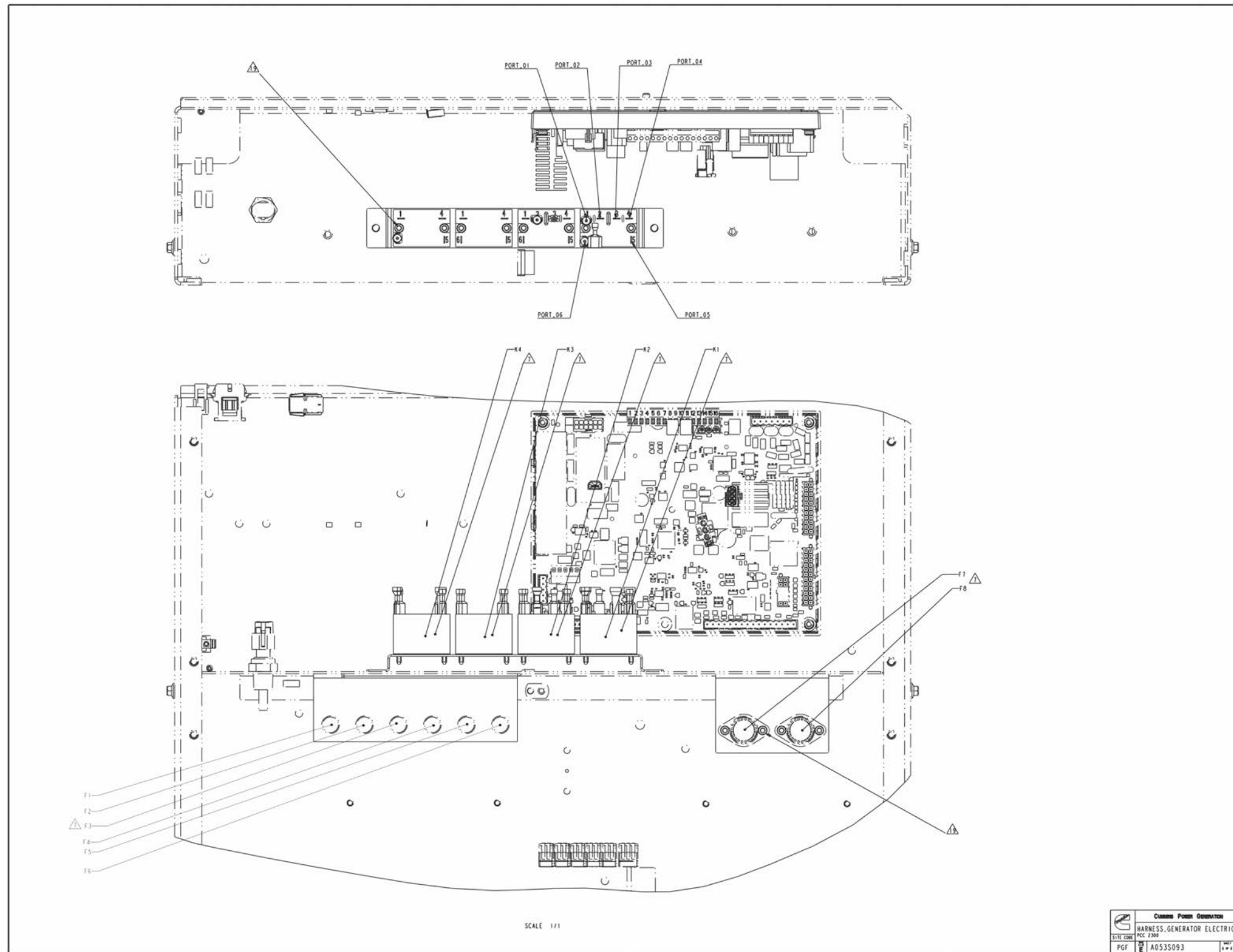

FIGURE 39. CONTROL BOX HARNESS DIAGRAM (SHEET 4 OF 4)

This page is intentionally blank.

Appendix D. Seismic Requirements

Table of Contents

Figure 40. Seismic Installation Requirements (Sheet 1 of 4) 103
Figure 41. Seismic Installation Requirements (Sheet 2 of 4) 104
Figure 42. Seismic Installation Requirements (Sheet 3 of 4) 105
Figure 43. Seismic Installation Requirements (Sheet 4 of 4) 106

The drawings included in this section are representative. For current complete information, refer to the drawing package that was shipped with the unit.

D.1 Seismic Installation Instructions

REL NO	LTN NO	REVISION	OWN	CKD	APVD	DATE
ECO-165950	A	1	AGJ	AGJ	M. WICKMANN	07NOV16

SEISMIC INSTALLATIONS NOTES:

1. THE DESIGN OF POST-INSTALLED ANCHORS IN CONCRETE USED FOR THE COMPONENT ANCHORAGE IS PRE-QUALIFIED FOR SEISMIC APPLICATIONS IN ACCORDANCE WITH "ACI 355.2-07" AND DOCUMENTED IN A REPORT BY A REPUTABLE TESTING AGENCY. (EX. THE EVALUATION SERVICE REPORT ISSUED BY THE INTERNATIONAL CODE COUNCIL)
2. ANCHORS MUST BE INSTALLED TO AN EMBEDMENT DEPTH AS RECOMMENDED IN THE PRE-QUALIFICATION TEST REPORT AS DEFINED IN NOTE 1. FOR "CBC 2016" APPLICATIONS.
3. ANCHORS MUST BE INSTALLED IN MINIMUM 3000 PSI COMPRESSIVE STRENGTH NORMAL WEIGHT STRUCTURAL CONCRETE. CONCRETE AGGREGATE MUST COMPLY WITH "ASTM C33".
4. ANCHORS MUST BE INSTALLED TO THE TORQUE SPECIFICATION AS RECOMMENDED BY THE ANCHOR MANUFACTURER.
5. ANCHORS MUST BE INSTALLED IN LOCATIONS SPECIFIED ON THIS INSTALLATION DRAWING.
6. WASHERS MUST BE INSTALLED AT EACH ANCHOR LOCATION BETWEEN THE ANCHOR HEAD AND EQUIPMENT FOR TENSION LOAD DISTRIBUTION. WASHERS MUST BE TYPE A OR B PLAIN WASHERS MEETING ASME B18.21.1-2009. WASHER SIZE TO MATCH ANCHOR DIAMETER.
7. CONCRETE FLOOR SLAB AND CONCRETE HOUSEKEEPING PADS MUST BE DESIGNED FOR SEISMIC APPLICATIONS IN ACCORDANCE WITH "ACI 318-11".
8. ALL HOUSEKEEPING PAD THICKNESSES MUST BE DESIGNED IN ACCORDANCE WITH THE PRE-QUALIFICATION TEST REPORT AS DEFINED IN NOTE 1 OR A MINIMUM OF 1.5X THE ANCHOR EMBEDMENT DEPTH, WHICHEVER IS LARGEST (UNLESS NOTED OTHERWISE).
9. ALL HOUSEKEEPING PADS MUST BE DOWELLED OR CAST INTO THE BUILDING STRUCTURAL FLOOR SLAB AND DESIGNED FOR SEISMIC APPLICATION PER "ACI 318-11" AND AS APPROVED BY THE STRUCTURAL ENGINEER OF RECORD.
10. FLOOR MOUNTED EQUIPMENT (WITH OR WITHOUT A HOUSEKEEPING PAD) MUST BE INSTALLED TO A STEEL REINFORCED STRUCTURAL CONCRETE FLOOR THAT IS SEISMICALLY DESIGNED AND APPROVED BY THE ENGINEER OF RECORD TO RESIST ALL LOADS FROM EQUIPMENT BEING ANCHORED TO THE FLOOR.
11. COORDINATE REINFORCEMENT OF SUPPORT STRUCTURE WITH EQUIPMENT ANCHOR LOCATIONS.
12. ATTACHING SEISMIC CERTIFIED EQUIPMENT TO FLOOR OTHER THAN THOSE DESIGNED TO ACCEPT THE SEISMIC LOADS FROM CERTIFIED EQUIPMENT BY THE STRUCTURAL ENGINEER OF RECORD IS PROHIBITED.
13. INSTALLATION ONTO A STEEL ROOF STRUCTURE OR MANUFACTURED STEEL CURB SHALL BE COORDINATED WITH THE STRUCTURAL ENGINEER OF RECORD.
14. CONNECTIONS TO THE EQUIPMENT, INCLUDING BUT NOT LIMITED TO CONDUIT, WIRING FROM CABLE TRAYS, OTHER ELECTRICAL SERVICES OR OTHER CONNECTIONS, ARE THE RESPONSIBILITY OF THE INSTALLING CONTRACTOR AND BEYOND THE SCOPE OF THIS DOCUMENT. FLEXIBLE ATTACHMENTS MUST BE USED FOR SEISMIC CONNECTIONS TO ISOLATED COMPONENTS OR ISOLATED EQUIPMENT. THE FLEXIBLE ATTACHMENT MUST PROVIDE FOR ENOUGH RELATIVE DISPLACEMENT TO REMAIN CONNECTED TO THE EQUIPMENT AND FUNCTIONAL DURING AND AFTER A SEISMIC EVENT.
15. REFER TO GENSET OUTLINE DRAWINGS FOR WEIGHT, CG AND CONFIGURATION SPECIFICS.

UNLESS OTHERWISE SPECIFIED, ALL DIMENSIONS ARE IN MILLIMETERS		DIM TO NONE		DWN A. JOHNSON		CUMMINS POWER GENERATION	
DO NOT SCALE PRINT		DO NOT SCALE PRINT		CKD A. JOHNSON		INSTALLATION, GENSET	
DATE 07NOV16		DATE 07NOV16		APVD M. WICKMANN		SEISMIC REQUIREMENTS	
ANG TOL: ± 1.0°		SCALE: 1/1		SITE CODE		PGF D A056M541	
SHEET 1 OF 4		REV A		FOR INTERPRETATION, FIRST REFER TO PROPERTY OF CUMMINS POWER GENERATION GROUP		ARROW	

FIGURE 40. SEISMIC INSTALLATION REQUIREMENTS (SHEET 1 OF 4)

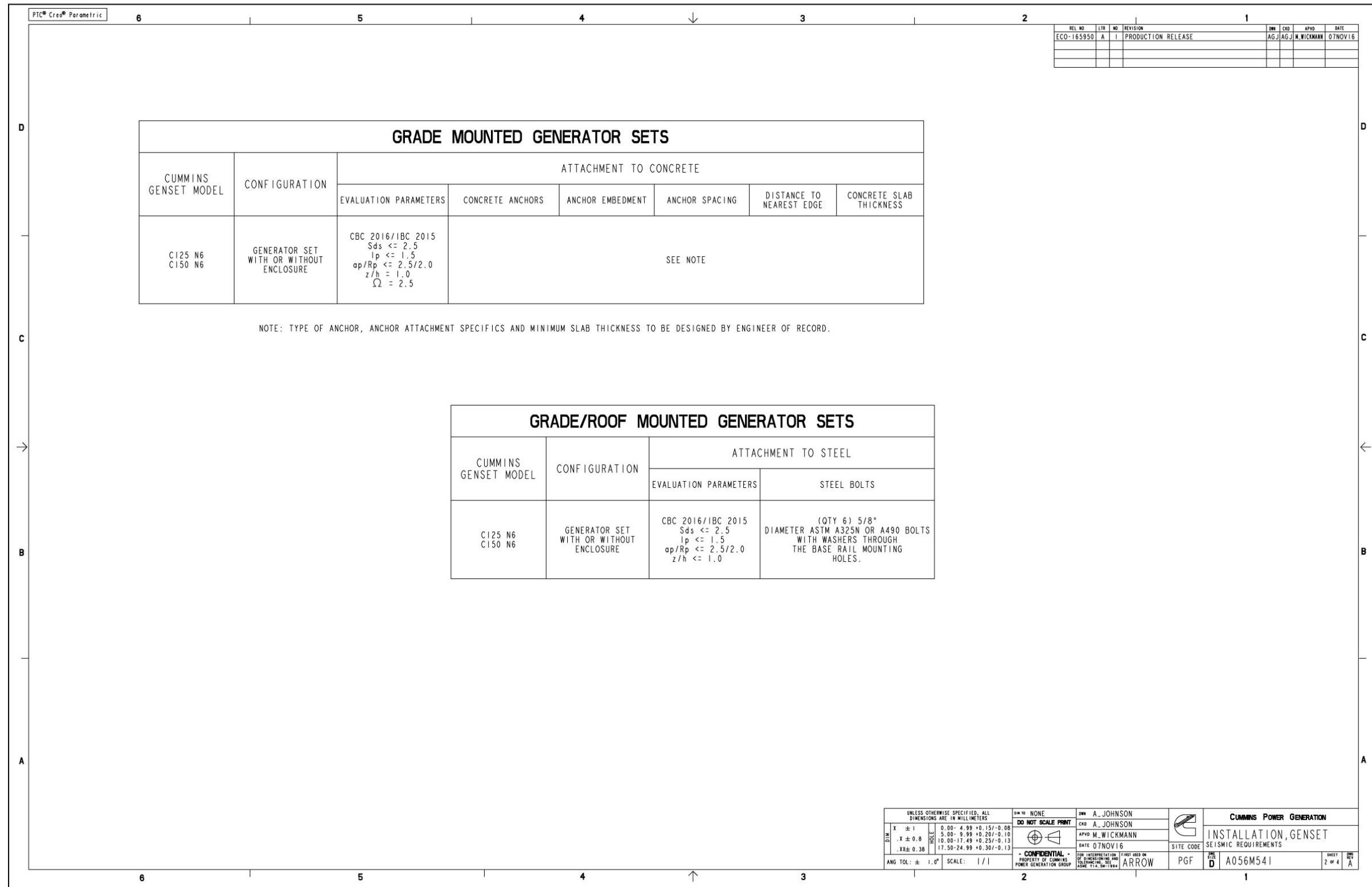

FIGURE 41. SEISMIC INSTALLATION REQUIREMENTS (SHEET 2 OF 4)

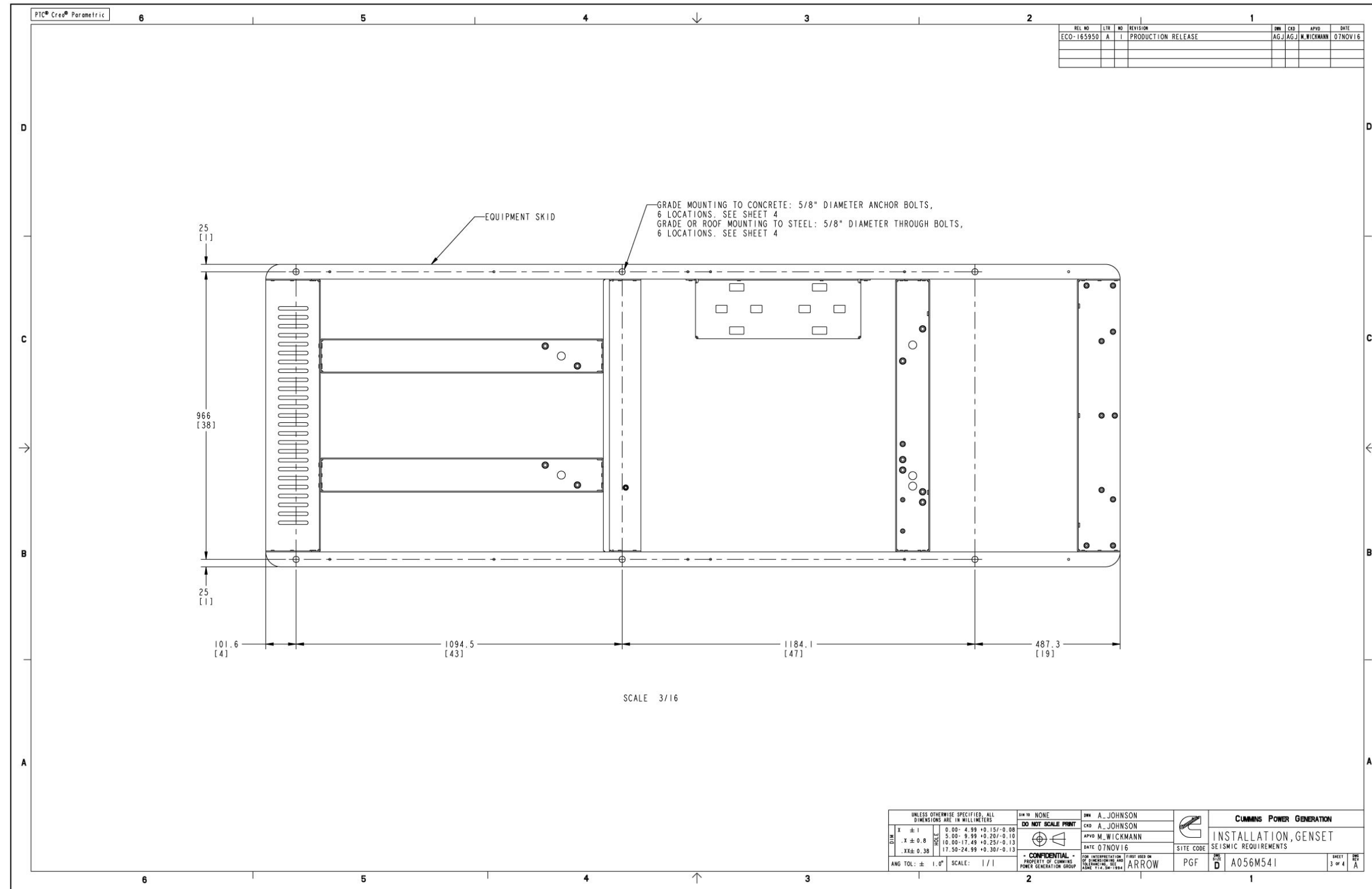

FIGURE 42. SEISMIC INSTALLATION REQUIREMENTS (SHEET 3 OF 4)

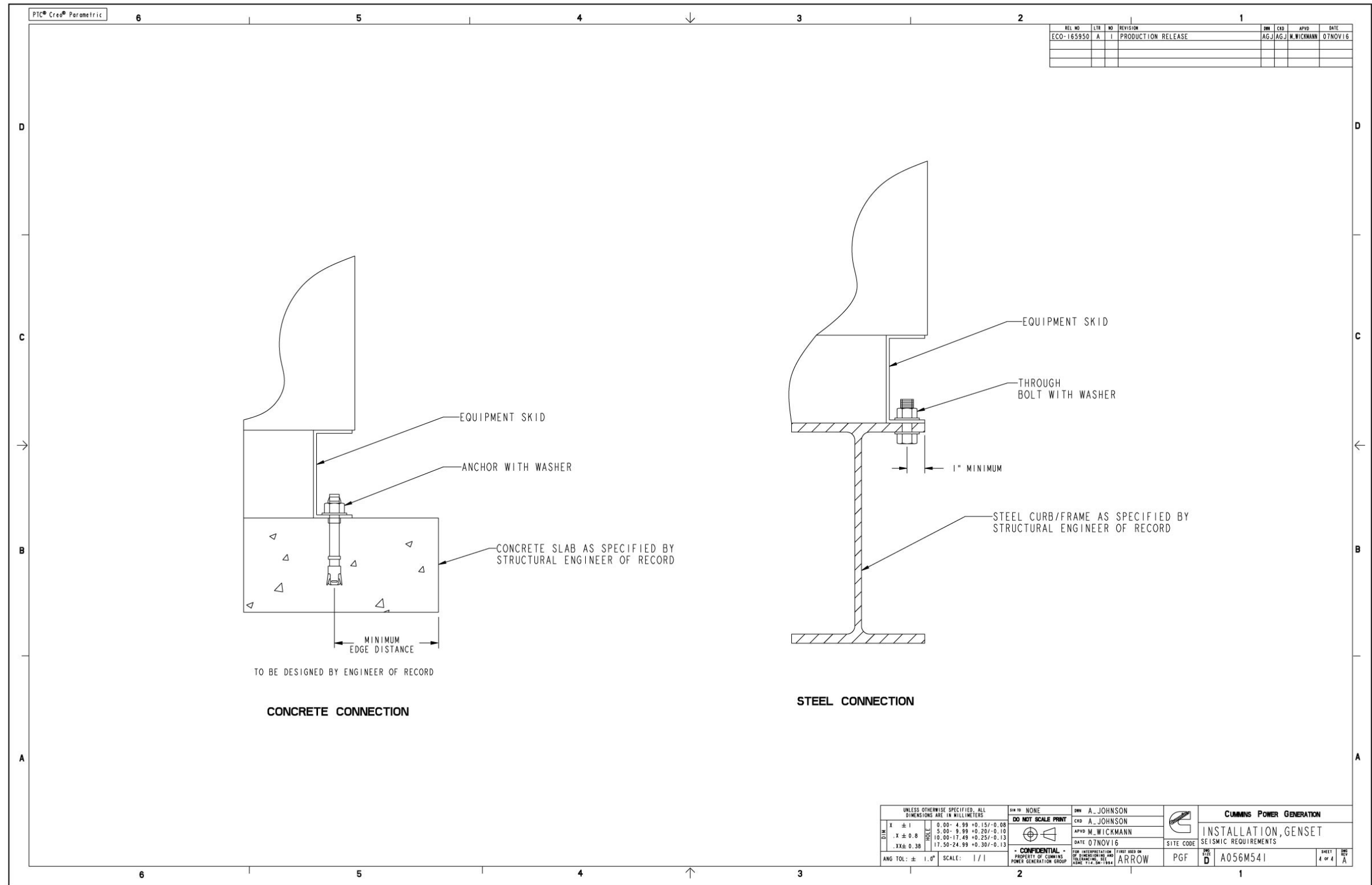

FIGURE 43. SEISMIC INSTALLATION REQUIREMENTS (SHEET 4 OF 4)

power.cummins.com

Copyright © 2017 Cummins Inc. All rights reserved.

Cummins, the "C" logo, PowerCommand, AmpSentry, and InPower are trademarks of Cummins Inc.

Other company, product, or service names may be trademarks or service marks of others.

Specifications are subject to change without notice.

